

# KALLISTA®

## For Town Whirlpool and Bath

### FEATURES

- Cast iron construction for better water temperature retention
- Variable speed pump
- 2 HP motor
- Bath mounted electronic control with feedback
- Additional remote control
- In-line water heater
- Complements multiple KALLISTA Suites

### CODES/STANDARDS APPLICABLE

Specified model meets or exceeds the following:

- ASME A112.19.1
- ASME A112.19.7
- IAPMO/UPC
- Underwriters Laboratories (UL1795)

P50035-H2

P50035-BA

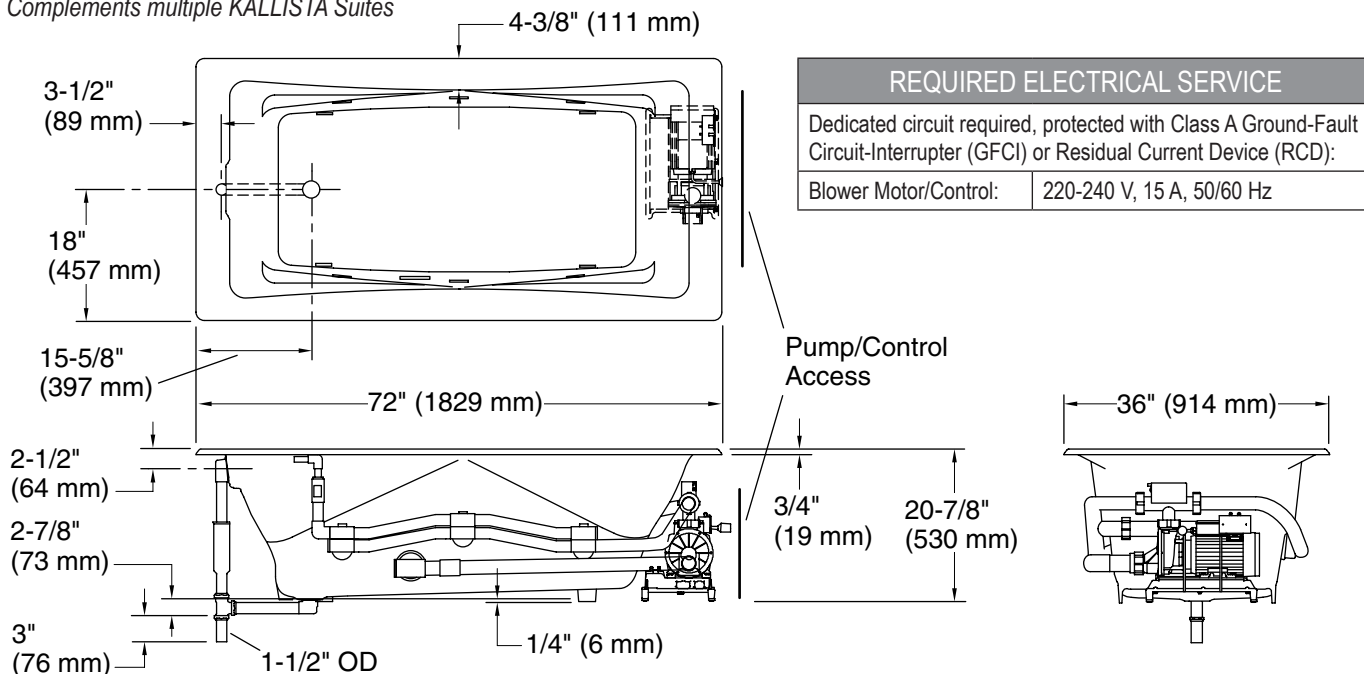

REQUIRED ELECTRICAL SERVICE	
Dedicated circuit required, protected with Class A Ground-Fault Circuit-Interrupter (GFCI) or Residual Current Device (RCD):	
Blower Motor/Control:	220-240 V, 15 A, 50/60 Hz

PRODUCT INFORMATION				
Fixture*:	Basin Area	Top Area	Weight	
Bathing Well	49" (1245 mm) x 22" (559 mm)	63" (1600 mm) x 28" (711 mm)	460 lbs (208.6 kg)	
	Water Depth	Capacity		
To Overflow	17" (432 mm)	89 gal (336.9 L)		
*Approximate Measurements For Comparison Only				
Pump	Heater	Voltage	Frequency	Amperage
1.5 HP	1.5 kW	240 V	50/60 Hz	11 A
Cutout Template			1034802-7	

ROUGHING-IN NOTES		
No change in measurements if connected with drain illustrated.		
Drop-in Cutout	70-1/4" (1784 mm) x 34-1/2" (876 mm)	
Minimum Access Panel:		
Pump/Control	24" (610 mm) W x 14" (356 mm) H	Required
All dimensions are nominal.		
Floor support under whirlpool must provide for a minimum of 1800 lbs (816.5 kg).		
Hot water supply must be 70% of capacity or greater.		

SPECIFIED MODEL				
Model	Description	Finishes		
P50035-H2	For Town Whirlpool Bath	<input type="checkbox"/> 0 Stucco White		
P50035-BA	For Town Bath	<input type="checkbox"/> 0 Stucco White		
Recommended Accessories				
P21576-00	Waste and Overflow	<input type="checkbox"/> CP Polished Chrome	<input type="checkbox"/> AD Nickel Silver	<input type="checkbox"/> AG Brushed Nickel <input type="checkbox"/> W6 Weathered Bronze
P51002-00	Whirlpool Trim Kit, 6-Jet	<input type="checkbox"/> CP Polished Chrome	<input type="checkbox"/> AD Nickel Silver	<input type="checkbox"/> AG Brushed Nickel
Optional Accessory				
P50036-00	Under-mount Kit	<input type="checkbox"/> NA		

We reserve the right to make revisions without notice in the design of products or in packaging unless this right has specifically been waived at the time the order is accepted.