

**FEATURES**

- Brass valve bodies
- Bath- or deck-mount
- Available with or without rigid connections
- 1/2" quarter-turn washerless ceramic disc valves
- High-flow valving

**CODES/STANDARDS APPLICABLE**

Specified model meets or exceeds the following:

- ASME/ANSI A112.18.1M
- CSA International B125
- IAPMO/UPC

**VALVE SYSTEM**  
**K-300-K, K-300-KR**

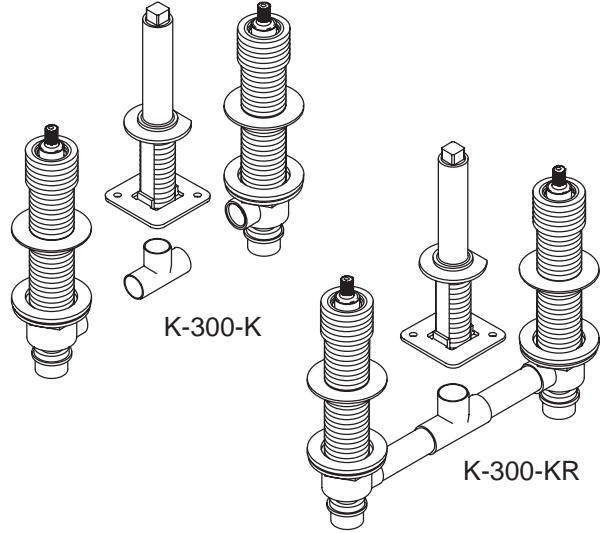

**COLORS/FINISHES**

- NA Not applicable

**SPECIFIED MODEL:** For complete faucet, both faucet trim and valve system must be specified.

Model	Description	
K-300-K	1/2" High-Flow Ceramic Disc Valve System	<input type="checkbox"/> NA
K-300-KR	1/2" High-Flow Ceramic Disc Valve System with Rigid Connections	<input type="checkbox"/> NA

**PRODUCT SPECIFICATION:**

Two-handle bath- or deck-mount, with or without rigid connections, 1/2" high-flow valve system shall feature brass valve bodies. Faucet shall feature 1/2" quarter-turn washerless ceramic disc valves, assuring positive handle stop positioning. High-flow valving allows water to flow 16-18 gpm at 45 psi. Valve system shall be Kohler Model K-300-\_\_\_\_\_-NA.

## PERFORMANCE DATA

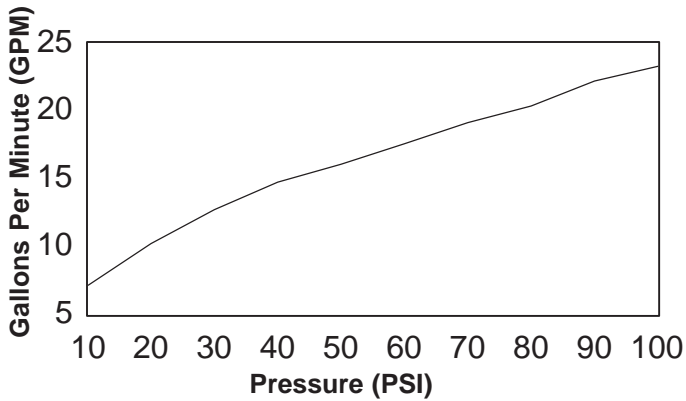

## INSTALLATION NOTES

For installations on a rough (unfinished) deck to be covered later with tile, the tile thickness must not exceed 1-1/4" (3.2cm).

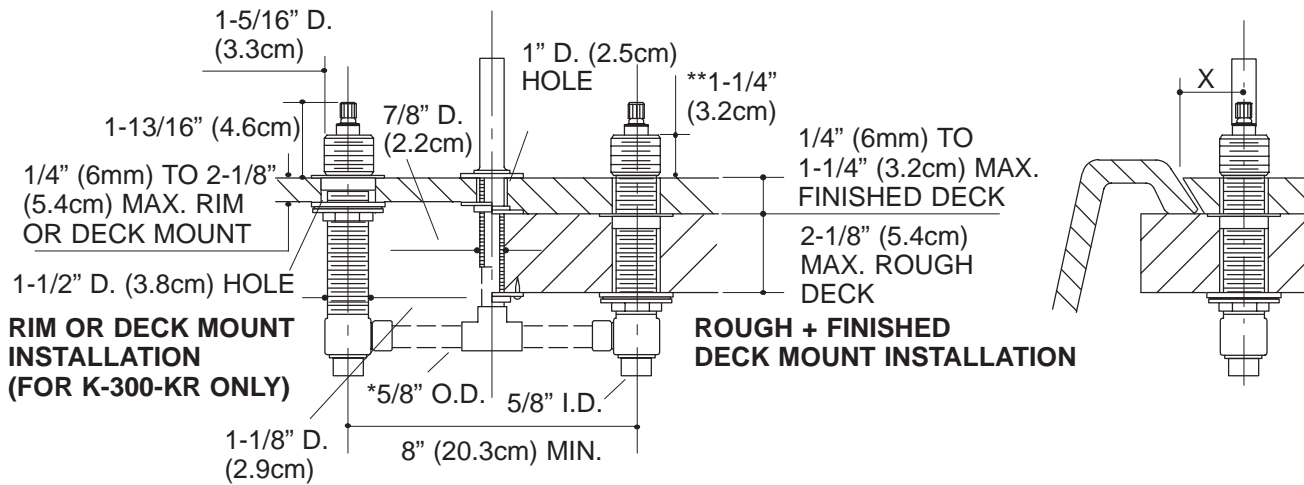

*Dashed lines indicate items to be supplied by installer.
**Dimension allows +/-1/4" (6mm) handle adjustment during handle trim installation.
X= Distance from centerline of spout inlet to front of spout base plus 1/2" (1.3cm).

## PRODUCT DIAGRAM