

22329T-7 Bath Filler Set

BEFORE YOU BEGIN

All information is based on the latest product information available at the time of publication. Kohler Co. reserves the right to make changes in product characteristics, packaging, or availability at any time without notice. Please leave these instructions for the consumer. They contain important information.

NOTES:

1. **Risk of electric shock.** Connect only to circuits protected by a Ground-Fault Circuit-Interrupter (GFCI) or Residual Current Device (RCD). Grounding is required. The unit should be installed and grounded by a qualified service representative.
2. **Risk of electric shock.** A licensed electrician should route all electrical wiring.
3. **Risk of electric shock.** Disconnect power before servicing.
4. **Risk of injury or property damage.** Please read all instructions thoroughly and determine all required components along with their installation locations before beginning installation.
5. Do not apply excessive heat near the valve or apply flux or acids directly onto the valve. This valve contains plastic and rubber components which will melt if heat is directly applied.
6. Do not apply petroleum-based lubricants to the valve components. Doing so will damage valve components.
7. Do not use oil-based, non-setting compounds, such as plumbers putty, on the threaded connections.
8. Observe all plumbing, electrical and building codes.
9. Make sure both hot and cold supply pipes are flushed thoroughly prior to connection to the Digital Mixer Valve.
10. If possible, install the valve prior to installing the interface(s). **When installing electrical outlet, please install an on/off switch in a suitable position for easy operation during network connection and troubleshooting.**
11. **Do not plug or unplug the cables on the valve when the valve is power-on, which may damage the product.**

STANDARD APPLICABLE

Special model meets or exceeds the following at date of manufacture: TIS

SPECIFICATION

Pressures	
Maximum Static Pressure	1 MPa (10 bar)
Maximum Maintained Pressure	500 kPa (5 bar)
Minimum Maintained Pressure	50 kPa (0.5 bar)
Supply Pressure Differential	Max 34.5 kPa (0.34 bar)
Minimum Flow Rate	6 L/Min
Temperatures	
Maximum Temperature (factory preset)	45°C
Maximum Temperature (setting range)	41°C - 48°C
Minimum Temperature	Thermostatic control down to 30°C / 15°C (IOT version)
Hot Water Range	55°C - 65°C
Cold Water Range	1°C - 20°C
Temperatures Stability	± 1°C at recommended supply conditions
Ambient Temperature	1°C - 40°C
Maximum Relative Humidity	95% non-condensing
Electrical	
Supply Voltage	100-240V, 2A, 50 Hz/60 Hz

TOOLS AND MATERIALS

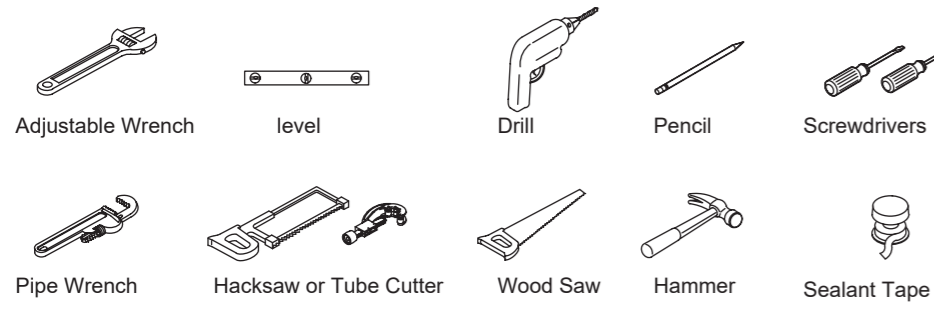

- Plus:
- Pipe Connectors
 - Wood and Framing Materials
 - PEX Tubing, Copper Tubing, PVC, PPR
 - (2) Water Hammer Arrestors (Recommended)
 - (2) Supply Shut-Off Valves

ROUGH-IN DIMENSIONS

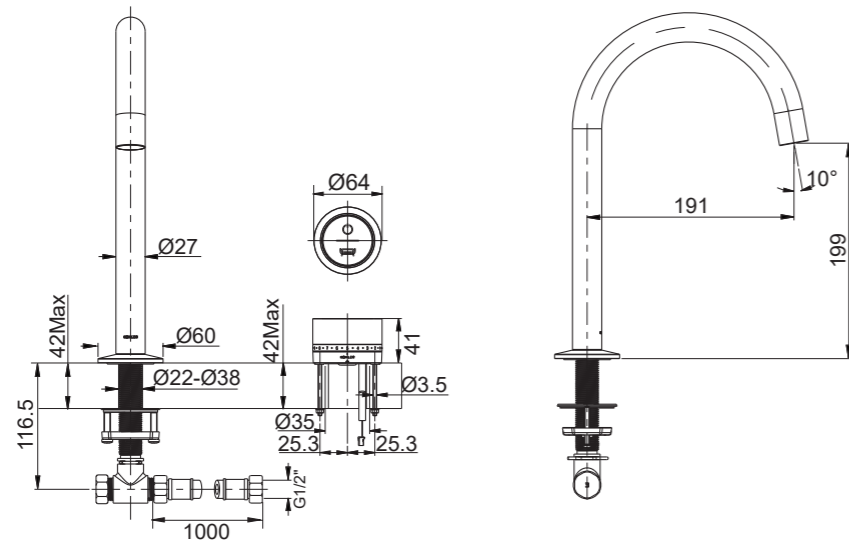
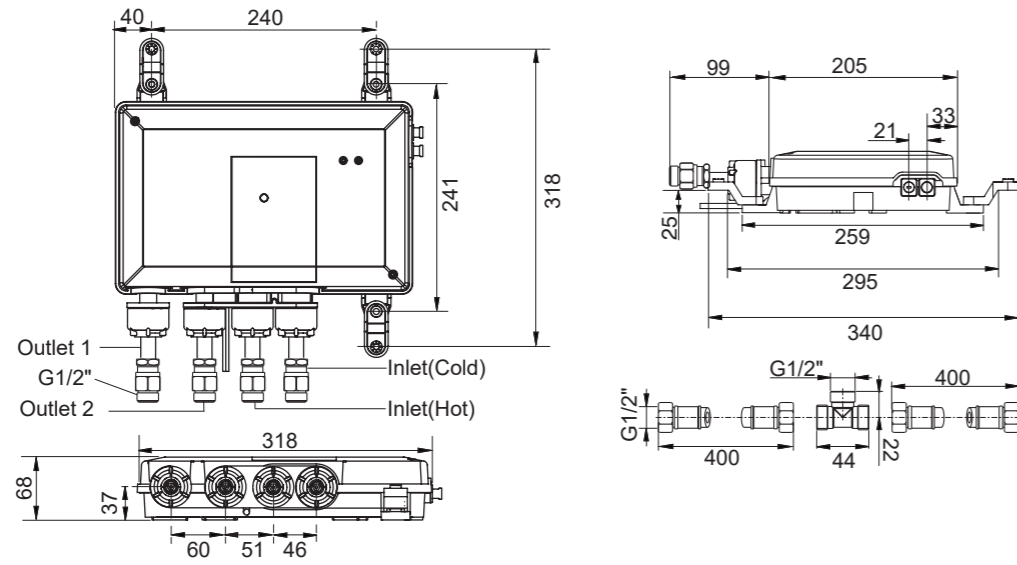

KOHLER®

SERVICE PARTS

DTV MODE

22329T-7 Bath Filler Set

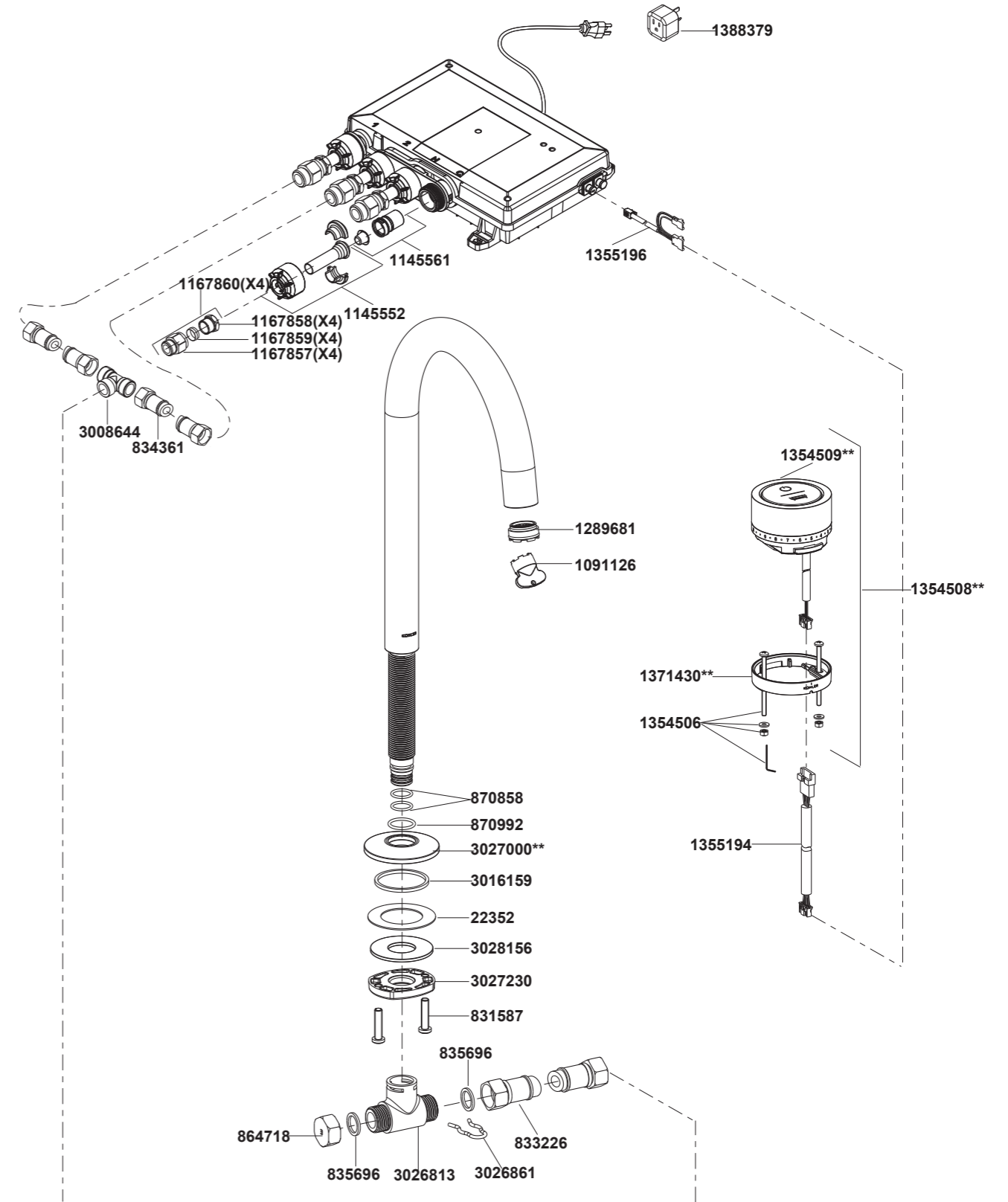

**Color code must be specified when ordering.
NOTE: For all Asia pacific regions (excluding China) add SP (SPxxxxxx**) in front of the part number when ordering.

Statistics of Contents of Toxic or Hazardous Substances or Elements

Part name	Toxic or Hazardous Substance or Elements					
	Lead (Pb)	Mercury (Hg)	Cadmium (Cd)	Hexavalent Chromium (Cr(VI))	Polybrominated biphenyls (PBB)	Polybrominated Diphenyl Ethers (PBDE)
Valve	×	○	○	○	○	○
Interface Assy	×	○	○	○	○	○
Connection Assy	×	○	○	○	○	○
Faucet Assy	×	○	○	○	○	○

○: Indicates that the substance in the material composition is below the high limits of the current requirements in GB/T 26572.

×: Indicates that at least one of the homogeneous substance in the material composition is above the high limits of the current requirements in GB/T 26572.

Note: the information provided is based on the supplier data and Kohler inspection results. The product is designed not to hurt the environment. Under current technology, all hazardous materials have been used in the smallest amounts possible. Kohler will strive to reduce the use of these hazardous materials used in this product.



The product "service life for environment protection" is 10 years; Kohler Company will specify product service life based on product characteristics. The product "service life for environment protection" is only effective when the product is used as described in the product specification.

INSTALLATION

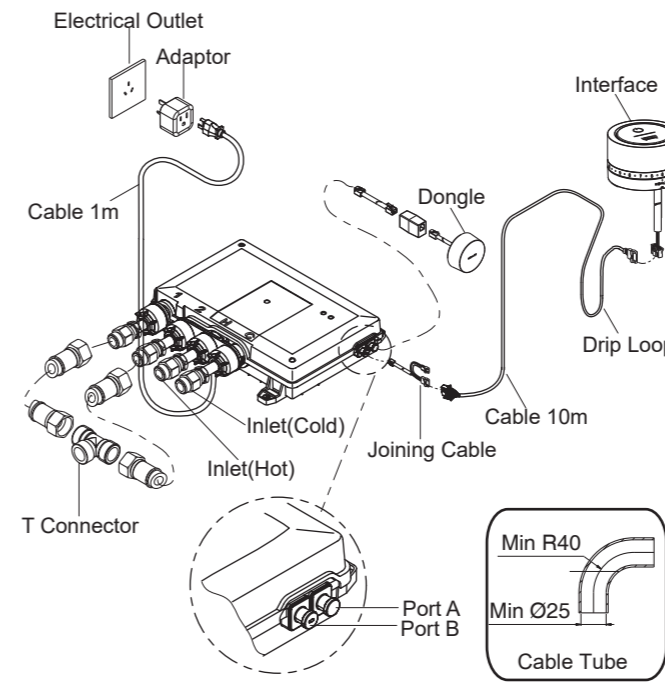

Preparation

NOTES: Make sure both hot and cold supply pipes are flushed thoroughly prior to connection to the Digital Mixer Valve.

If possible, install electrical outlet before installing the valve. Please turn off the electrical and water supplies before installation. Always keep the valve and outlet dry. Allow for enough slack in the cables for drip loops.

The interface should be installed inside the showering enclosure. Determine all required components along with their installation locations before beginning installation. **NOTES:** The valve can not be connected to two interfaces at the same time.

When routing pipes, keep in mind each valve outlet must correspond to the appropriate showering component for the preprogrammed or custom showering experiences to function properly. Please prepare cable tubes before routing cables as the dimension.

NOTES: Port A is for the dongle (not provided, 23777T) connection, port B is for joining cable.

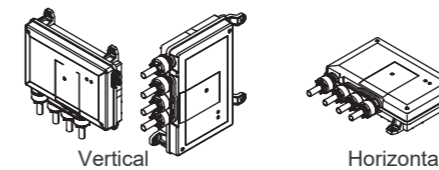

Install the Valve

NOTES: The Digital Mixer Valve may be installed in a loft space or in a convenient space provided enough room for maintenance. Failure to do so may result in an inability to carry out any maintenance.

Installation Direction of the Valve

Do not mount the valve with the inlets located at the top. Do not mount the valve with the inlets or cable sockets pointing up. Vertical and horizontal mounting options are shown as the figure.

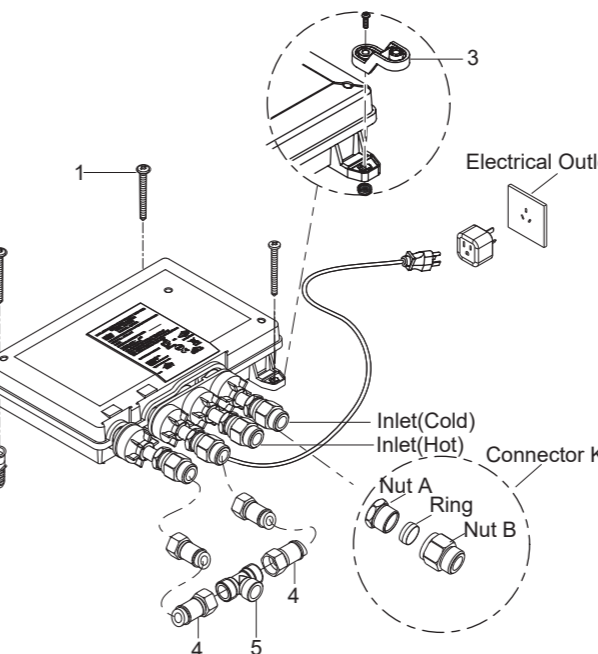

Installation Steps

- Mark the fixing holes in required positions, drill three holes on mounting surface according to the rough-in dimensions and diameter of the anchor(2).
- Press anchors into the holes, install and secure Digital Mixer Valve in position with fixing screws(1). **NOTES:** Install the offset foot(3) if needed.
- Install nut A, the ring and nut B onto inlet/outlet. Hand-tighten nut A and nut B. Hold nut A with a wrench, meanwhile tighten nut B with another wrench. **NOTES:** The connector kit must be pushed into the end towards valve direction, tighten it firmly.
- Connect hot and cold water supply pipes to Digital Mixer Valve.
- Connect the hoses(4) to the valve outlets and T-connector(5).
- Route pipes from T-connector to the installation location of bath spout.
- Route cables from valve to the interface installation location.

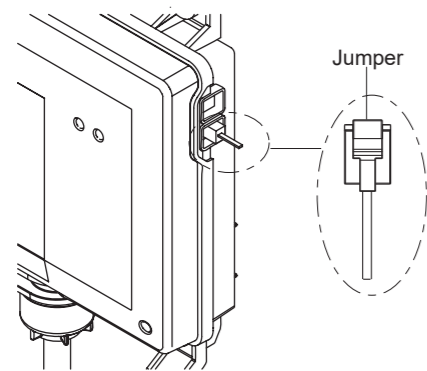

Check the Valve Installation

- Turn on the water supply to the valve.
- Check all connections for leaks and make any adjustments as needed.
- Disconnect the power from the valve.
- Insert the jumper into either of the valve sockets.
- Reconnect the power to the valve.
- Wait 10 seconds for the valve to initialize; outlets will activate.
- Check all connections for leaks.
- Disconnect the power and remove the jumper.
- Reconnect the power to the valve for normal usage.

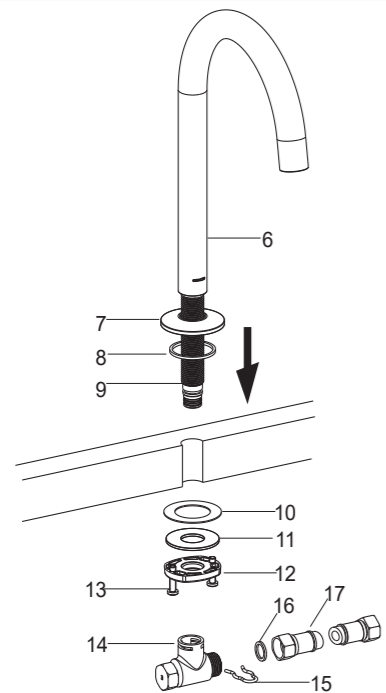

Install the Bath Spout

- Insert the washer(8) to the groove of the escutcheon(7). Slide the escutcheon onto the bottom of the spout(6). Insert the spout kit into the mounting hole of bathtub with escutcheon.
- From underside of the bathtub, place the washer (10), steel washer(11) and threaded ring(12) to the shank(9). Adjust the position to keep the spout face front. Screw the threaded ring and tighten the screws (13) to secure the spout.
- Install the supply tee(14) onto the shank and tighten by the hook(15).
- Insert the washer(16) to the hose(17), Connect the hose(17) to tee supply. The other end of the hose should be connected to corresponding valve outlet.

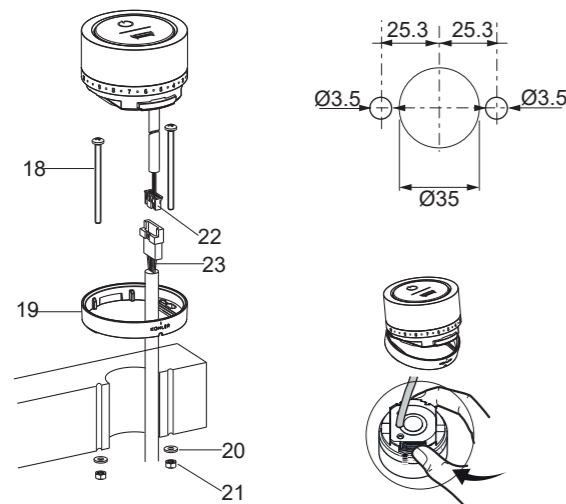

Install the Interface

- Press the buckle at the back of the interface to uninstall the backplate(19). Place the backplate at the position where you intend to install the interface. Make sure that the backplate is level, and keep "KOHLER" logo pointing front.
- Mark the positions of the fixing holes on the bathtub. Drill the holes for the interface cable per the dimensions.
- Fit the backplate to the bathtub with the fixing screws(18). Make sure that the backplate is level, and keep "KOHLER" logo pointing front. Tighten the nut(21) with a washer(20) to secure the interface.
- Connect the cable(22) at the back of the interface to the cable(23) that comes from the valve.
- Locate the top of the interface in the backplate and press down to secure in position.

Troubleshooting Table(cont.)

Symptoms	Probable Cause	Recommended Action
8. Blend temperature drift or temperature cycling.	A. Fluctuating water supply temperature. B. Pressure difference greater than 5 psi (34.5 kPa) between the hot and cold supply lines. C. If none of the recommended actions for the above issues correct the symptom, the valve requires servicing.	A. Check the inlet temperature differentials and verify they are sufficient. Refer to "SPECIFICATION" section. B. Install pressure regulators to bring the supplies within 5 psi (34.5 kPa) of each other. C. Contact your Kohler Co. Authorized Service Representative.
9. Water leaking from the valve. CAUTION: Risk of personal injury or product damage. Turn off the main power and water supply.	A. Connections are not secure. B. Seals are worn or damaged. C. Internal leak.	A. Check all connections. Make adjustments as needed. B. Order a seal service pack and replace all seals. C. Unit requires overhaul. Contact your Kohler Co. Authorized Service Representative.
10. Hot water only, the valve shuts down.	A. Hot and cold lines are reversed.	A. Switch hot and cold water supply connections. Verify the hot water supply is connected to the inlet marked "H" and the cold water supply is connected to the inlet marked "C."
11. No Lights on interface.	A. Not connected to valve. B. No power to valve. C. Faulty user interface.	A. Check connections, connect if needed. B. Check power supply, connect if needed. C. Contact your Kohler Co. Authorized Service Representative.
12. Interface Button Flashing (2 times a second).	A. Stuck button on interface. B. Intermittent connection to valve. C. Digital Mixing Valve fault. D. Wrong interface connected.	A. Contact your Kohler Co. Authorized Service Representative. B. Check connections, connect if needed. C. Contact your Kohler Co. Authorized Service Representative. D. Contact your Kohler Co. Authorized Service Representative.
13. Temperature Indicator and Interface button flashing (2 times a second).	A. Over temperature error	A. Contact your Kohler Co. Authorized Service Representative.
14. All Interface Button Flashing (2 times a second) & Temperature Indicator and Interface button flashing (2 times a second)		A. Turn off the mains power to the product & reboot after 10 seconds. If the fault is not rectified, then Contact your Kohler Co. Authorized Service Representative.

CLEANING INSTRUCTIONS

All Finishes: Clean the finish with mild soap and warm water. Wipe entire surface completely dry with clean soft cloth. Many cleaners may contain chemicals, such as ammonia, chlorine, toilet cleaner etc. which could adversely affect the finish and are not recommended for cleaning.

Do not use abrasive cleaners or solvents on Kohler faucets and fittings.

Troubleshooting Table(cont.)		
Symptoms	Probable Cause	Recommended Action
2. The interface power indicator is lit, but the system will not turn on.	A. Interface cable connections may be loose. B. If the above recommended action does not correct the symptom, the interface or valve requires servicing.	A. Check all interface cable connections, connect if needed. B. Contact your Kohler Co. Authorized Service Representative.
3. The interface functions normally but no water flows from the components.	A. Valve outlets may be blocked. B. Fittings/Spray faces may be blocked. C. Hot and cold water supplies are not turned on. D. The valve memory may require resetting. E. If none of the recommended actions for the above issues correct the symptom, the valve requires servicing.	A. Check the valve outlets for blockage or debris. Clean the outlet screens. Refer to the "CARE AND MAINTENANCE" section. B. Clean the spray faces and any screens in your fittings. C. Turn on the water supply to the valve. D. Disconnect and reconnect the valve power cord from the electrical outlet. E. Contact your Kohler Co. Authorized Service Representative.
4. Maximum blend temperature too hot or too cold.	A. Incorrect maximum temperature setting. B. If the above recommended action does not correct the symptom, the interface or valve requires servicing.	A. Refer to the "Set the Maximum Temperature" section. B. Contact your Kohler Co. Authorized Service Representative.
5. Continuous flow.	A. System will not switch off. B. Flow rate exceeds 10 gpm (45.5 L/min) from one outlet.	A. Turn off the water and power supply and contact your Kohler Co. Authorized Service Representative. B. Ensure flow restrictors are installed in both outlets.
6. Only cold water flows from the outlets.	A. Hot water supply is either not turned on or not connected to the valve inlet. B. Hot water inlet is blocked. C. The hot water supply is exhausted. D. If none of the recommended actions for the above issues correct the symptom, the valve requires servicing.	A. Check if the hot water supply is turned on and connected to the valve inlet. B. Check the hot water inlet screen for blockage. Clean or replace the inlet screen. C. Allow time for the water heater to come up to temperature. D. Contact your Kohler Co. Authorized Service Representative.
7. Fluctuating or reduced flow rate. Valve is functioning properly.	A. Valve inlets may be blocked. B. Fittings/Spray faces may be blocked. C. Water outlet pressure is low. D. Fluctuating supply pressure. E. Water supply temperatures are not within the recommended range.	A. Check the valve inlets for blockage or debris. Clean the inlet screens. Refer to the "CARE AND MAINTENANCE" section. B. Clean the spray faces and any screens in your fittings. C. Check that the flow rate is at or above the minimum rate required. Refer to "SPECIFICATION" section. D. Verify that the dynamic inlet pressures are within specifications. Refer to "SPECIFICATION" section. E. Check if inlet water temperatures are within the recommended range.

COMPLETE THE INSTALLATION

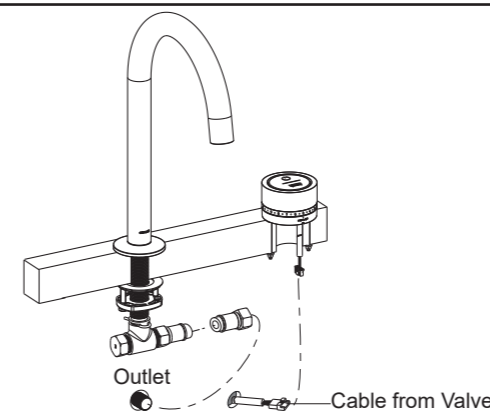

NOTES: Do not plug in the power cord until all interface cables are connected.

- NOTES:** Make drip loops in all cables and cords.
- Route the interface cable in the wall from the valve location to the interface installation location.
 - Connect the interface cable to the valve.
 - Connect the hose to the connector and the corresponding valve outlets.
 - Verify there is power to the electrical outlet.
 - Plug the power cord into the outlet.

INSTALLATION CHECKOUT

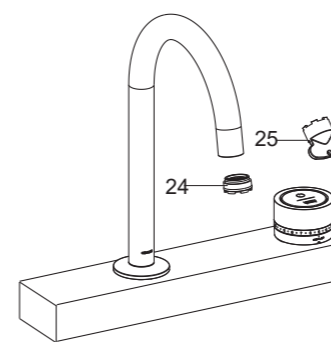

- Make sure all the connections are tightened.
- Uninstall the aerator(24) with the tool(25).
- Turn on the water supplies to the valve.
- Press the icon on the interface. The screen will be lit and the outlets should be turned on. Check all connections for leaks and make adjustments as needed. Run water through the spout to remove any debris. Turn off the spout. Reinstall the aerator.
- Verify that the water flow is sufficient for your showering needs. Remove the regulator in the outlet of the valve if needed.

NOTE: The maximum water temperature to the outlets is limited to 120°F (49°C). The valve will automatically shut down if the temperature exceeds 120°F (49°C).

OPERATION INSTRUCTIONS

How to Operate the Interface

On/Off Symbol - (Top Button)

Turn the bath spout On/Off.

Bath Spout Symbol - (Bottom Button)

Turn bath spout On/Off.

NOTES: Pressing either the On/Off button or Bath Spout button can turn on/off the spout. But the water flowrate is different under the two ways.

Rotary movement selects showering temperature. The larger the number which the temperature setting mark is aligned, the higher the temperature. "C" is for full cold water, "H" is for pre-set Max temperature.

NOTES: Press bath spout symbol to start the bathfill mode, the water temperature and bathfill time are pre-set. The factory default Bath Fill Preset is 5 minutes duration. If adjust the temperature indicator, it will exit the bathfill mode, the longest bath fill duration is 30 minutes. **NOTES:** The factory default maximum temperature is set to 45°C.

When you turn on the product and water begins to flow, the temperature indicator light will begin to flash to show the product is warming up. Once the preselected outlet temperature has been reached, the indicator light will stop flashing.

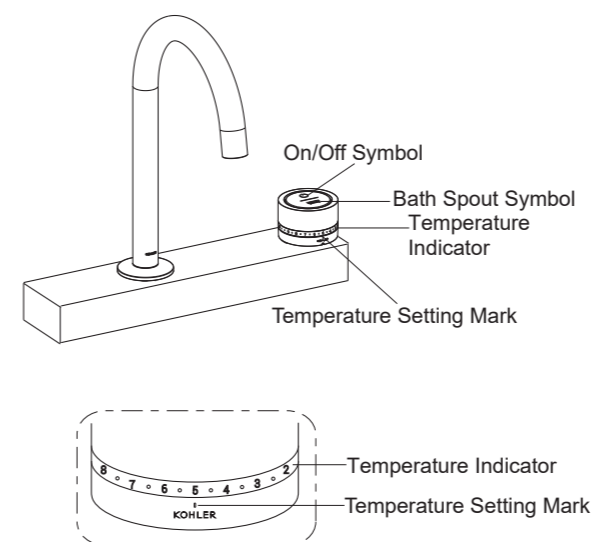

SETTINGS

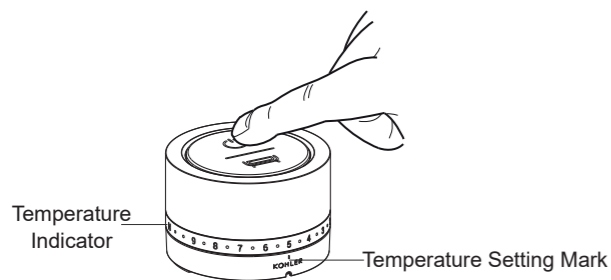

Maximum Temperature Setting

When the spout is in the off position, hold down the On/Off button (top half) for 10 seconds, the lights will pulse slow to indicate setting mode.

Adjust temperature indicator according to the table below to set desired maximum temperature. The scale on the indicator which the temperature setting mark is aligned represents the selected maximum temperature.

Caution! Make sure that the maximum outlet temperature is suitable and safe for all users.

Temp Indicator Position	Temp (°C)
C	Exit No Change
1 - 3	41
4 - 6	45
7 - 9	48
H	Exit No Change

Press the On/Off button to set the maximum temperature. The temperature indicator light will flash three times to confirm the setting has been completed.



Bath Fill Preset

The water temperature and bath filling can be preset as needed, which brings users an one-button start bath experience. The setting steps are as follows:

Push down the plug in the bath.

Hold down the Bath Symbol Button (bottom half) for 5~10 seconds approx. until the Bath Symbol Button flashes. Press the Bath Symbol Button to start the bath filling.

Rotate the interface to adjust the temperature indicator to set the temperature. On reaching the ideal fill level and desired temperature, press the Bath Symbol Button to stop the water, the temperature indicator will flash three times to confirm and save the Bath Fill Preset.

NOTES: The preset fill duration will affect the water volume in the bathtub. If the bath filling is not the desired water volume, the user needs to reset it.

Note! Factory Default Bath Fill Preset is 5 minutes duration at 42°C Inlet Temperature.

Bath Fill Preset temperature will calculate the average temperature over the Preset fill duration & take into account adjustments made to the User Interface rotary temperature dial during this time period.

NOTES: Press the On/Off symbol button(top half) can exit the setting.

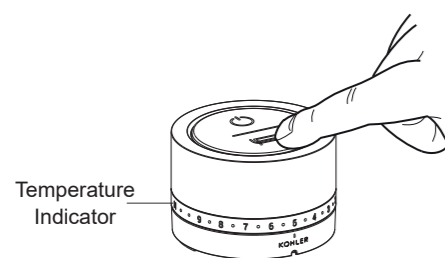

CARE AND MAINTENANCE

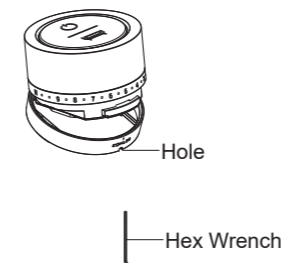
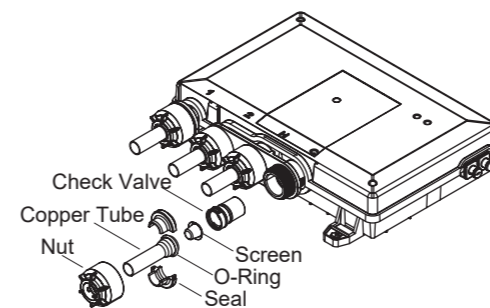

Clean the Inlet Screen

Disconnect the power and turn off the water supply. Unthread the plastic nuts from the hot and cold inlets.

Remove the copper tubes. The O-ring and screen may be attached to the end of the tube.

If the screen remains in the check valve, use a small flat-blade screwdriver to gently pull the check valve from the valve inlets.

Remove the screens from the copper tubes or check valves.

Clean the screens to remove any dirt or debris. Rinse or replace the check valves and screens. Reassemble the inlet connections.

Uninstall the Button of the Interface

Insert one end of a hex wrench into the hole on the backplate to remove the button, replace it if needed during maintenance.

TROUBLESHOOTING

WARNING: Risk of electric shock. Disconnect power before performing any maintenance. When disconnected, the product will no longer be electrically live, which will eliminate the risk of electric shock.

CAUTION: Risk of personal injury. The valve may contain hot water; be careful when draining any residual water.

NOTES: Turn off the power and water supply to the valve before performing any maintenance to the valve.

It is recommended that any valve maintenance should be performed by a Kohler Co. Authorized Service Representative.

This troubleshooting guide is for general aid only. For service and installation issues or concerns, call 800-820-2628.

Troubleshooting Table

Symptoms	Probable Cause	Recommended Action
1. Control panel is not lit.	<p>A. Valve is not plugged into the outlet.</p> <p>B. Interface cable connections may be loose or disconnected.</p> <p>C. Circuit breaker has been tripped.</p> <p>D. The valve memory may require resetting.</p> <p>E. A "straight-through" cable or coupler was used to connect the interface to the valve.</p> <p>F. If none of the recommended actions for the above issues correct the symptom, the valve or interface requires servicing.</p>	<p>A. Plug the valve into an outlet.</p> <p>B. Check all interface cable connections, connect if needed.</p> <p>C. Reset the circuit breaker.</p> <p>D. Disconnect and reconnect the valve power cord from the electrical outlet.</p> <p>E. Connect the interface to the valve using a "cross-over" cable and coupler.</p> <p>F. Contact your Kohler Co. Authorized Service Representative.</p>