

Thank you for purchasing a Mira Mode. You must read this guide thoroughly, and having done so, keep it handy for future reference. For step-by-step installation videos, datasheets or spares information, please visit the Mira Showers website.

Contents

Important Safety Information	3
Pack Contents	6
Guarantee	12
Recommended Usage	12
Products Covered	12
Patents and Design Registration	12
Specifications	13
Suitable Plumbing Installations	16
Showering Maximum Flow Rate	18
Installation Schematic	19
General Installation	21
Installation	
Digital Mixing Valve	22
Ceiling Fed Shower Fittings	27
Ceiling Fed Deluge Head	31
Rear Fed Shower Fittings	34
Rear Fed Deluge Head	39
Bath Filler	41
User Controller	44
Commissioning & Starting the shower	47
Using the Shower	52
Set Up: Controller	53
Bathfill Preset Adjustment	55
User Interface Function Guide	56
Accessories	56
Set Up: Mobile App	57
Fault Diagnosis	58
Cleaning & Maintenance	64
Back Page	68

Important Safety Information

Products manufactured by Kohler Mira Ltd. are designed to be safe, provided that they are installed, used, and maintained in good working order, in accordance with our instructions and recommendations. Follow all warnings, cautions and instructions contained in this guide, and on, or inside the product. Failure to follow the instructions provided with this product will invalidate the guarantee.

Warning! To reduce the risk of fire, electric shock or injury please read the important information listed below.

1. Installation of this product must be carried out in accordance with these instructions by qualified, competent personnel. Read all instructions before commencing installation.
2. The electrical installation must comply with BS 7671 (commonly referred to as the IET Wiring Regulations) and all relevant building regulations, or any particular regulation or practice specified by the local electricity supply company.
3. The plumbing installation must comply with all national or local water regulations and all relevant building regulations, or any particular regulation or practice specified by the local water supply company.
4. Isolate the electrical and water supplies before commencing installation.
5. For any copper pipework ensure supplementary bonding is provided in accordance with the wiring regulations.
6. A 30 mA Residual Current Device (RCD) must be included in the electrical circuit. This may be part of the consumer unit or a separate unit.
7. **DO NOT** install the digital mixing valve or user controller in areas with high humidity and temperature (e.g. steam rooms and saunas).
8. **DO NOT** install the digital mixing valve or fittings where they may be exposed to freezing conditions. Ensure that any pipework that could become frozen is properly insulated. Refer to 'General Installation' section for more information.
9. **DO NOT** perform any unspecified modifications, drill or cut holes in the product other than instructed by this guide. When servicing only use genuine Kohler Mira replacement parts.

10. If the product is dismantled during installation or servicing then, upon completion, an inspection must be made to ensure all electrical connections are secure and that there are no leaks.
11. **DO NOT** operate the product if water is leaking from inside the valve module. Isolate electrical and water supplies to the product and refer to the fault diagnosis section.
12. **DO NOT** allow the digital mixing valve to freeze. Isolate and drain down the valve if the property is being left for a period of time during winter. You may need to contact a plumbing professional to carry out this procedure.
13. **DO NOT** operate the product if the digital mixing valve has been exposed to freezing conditions. Internal damage may have occurred, which may result in a leak once the product has thawed. Isolate the power and water to the digital mixing valve and slowly allow to thaw (e.g. open the loft hatch to warm the loft space). Slowly un-isolate the water supply, and if no sign of leaks, re-power the digital mixing valve and check for normal operation. It is recommended to monitor the digital mixing valve periodically and check for leaks. If you are concerned or unsure, please contact a plumbing professional.
14. Make sure that you fully understand how to operate this shower and make sure that it is properly maintained in accordance with the instructions given in this manual.
15. Children younger than 3 years old should not use this shower. Children 3 to 8 years should only use this shower under continuous supervision. Children 8 years and above and persons with reduced physical, sensory, or mental capabilities or lack of experience or knowledge can use the shower if they are given supervision or instruction concerning use of the appliance in a safe way and understand the hazards involved.
16. **DO NOT** allow children to play with the product.
17. **DO NOT** allow children to clean or perform any user maintenance without supervision.
18. Children under 8 must be supervised when bathing or showering.

19. The water temperature needs to be set at a suitable temperature (body temperature is approximately 38°C). Babies and Children are more sensitive to temperature than adults and it is recommended to check the delivered water temperature is less than 37°C.
20. The maximum mixed water temperature from the product is 48°C to take into account losses in metal baths. It is not a safe bathing or showering temperature.
21. Always check the water temperature is safe before bathing or showering.
22. **DO NOT** use excessive force when making connections.
23. Avoid layouts where the shower hose will be sharply kinked. This may reduce the life of the hose.
24. The position of the shower fittings must provide a minimum air gap of 25 mm between the handshower and the spill over level of any bath, shower tray or basin. There must be a minimum distance of 30 mm between the handshower and the spill over level of any toilet, bidet or other appliance with a Fluid Category 5 backflow risk.
25. **DO NOT** operate the valve at voltages other than that stated on the rating label.
26. This appliance is only to be used and supplied at SELV (Safety Extra Low Voltage) using only the supplied detachable power supply unit.
27. The supply cord of the power supply unit cannot be replaced. If the cord is damaged the power supply must be replaced.
28. In the event of a cold water failure, the product is designed to reduce the flow. Depending on the temperature of the hot water, the valve may shut down to prevent scalding.
29. **Warning!** Never remotely operate or alter any of the Mira Activate shower settings if it is already occupied and / or being used by another person or if you are not in the vicinity of the outlet. This could result in flooding of the shower cubical or scalding of the user.
30. Always disconnect the appliance from the supply before assembling, disassembling or cleaning.

Pack Contents

Digital Mixing Valve High Pressure/Combi

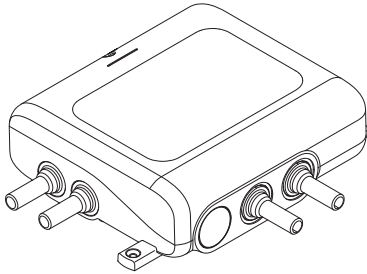

Digital Mixing Valve



2 x Push-Fit Isolators (15 mm Pipework Only)



1 or 2 x Outlet Connector (Depending on number of outlets)



3 x Fixing Screws

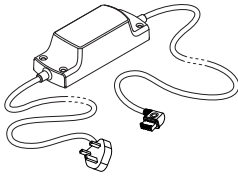

1 x Power Supply



3 x Wall Plugs



2 x Pozi Screws (3.5 x 12 mm)



2 x Fixing Feet

Digital Mixing Valve Pumped/Gravity

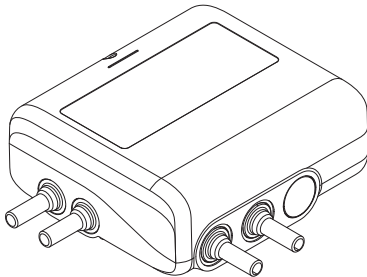

Digital Mixing Valve



2 x Push-Fit Isolators (15 mm Pipework Only)



1 - 2 x Outlet Connector (Depending on number of outlets)



3 x Fixing Screws

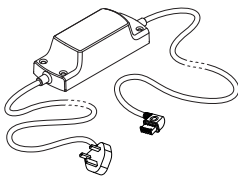

1 x Power Supply



3 x Wall Plugs



2 x Pozi Screws (3.5 x 12 mm)



2 x Fixing Feet

Ceiling Fed Shower Fitting

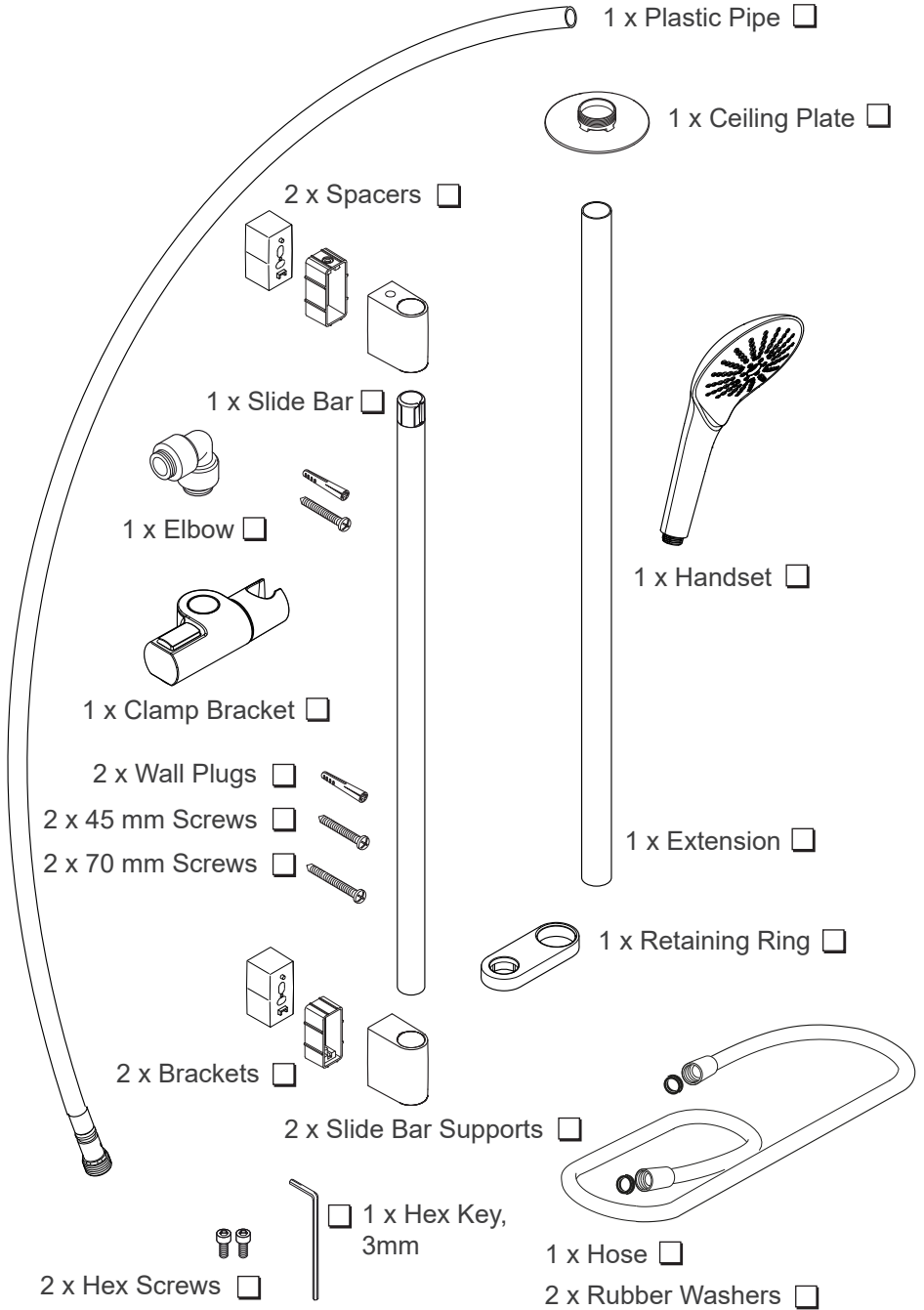

Rear Fed Shower Fitting

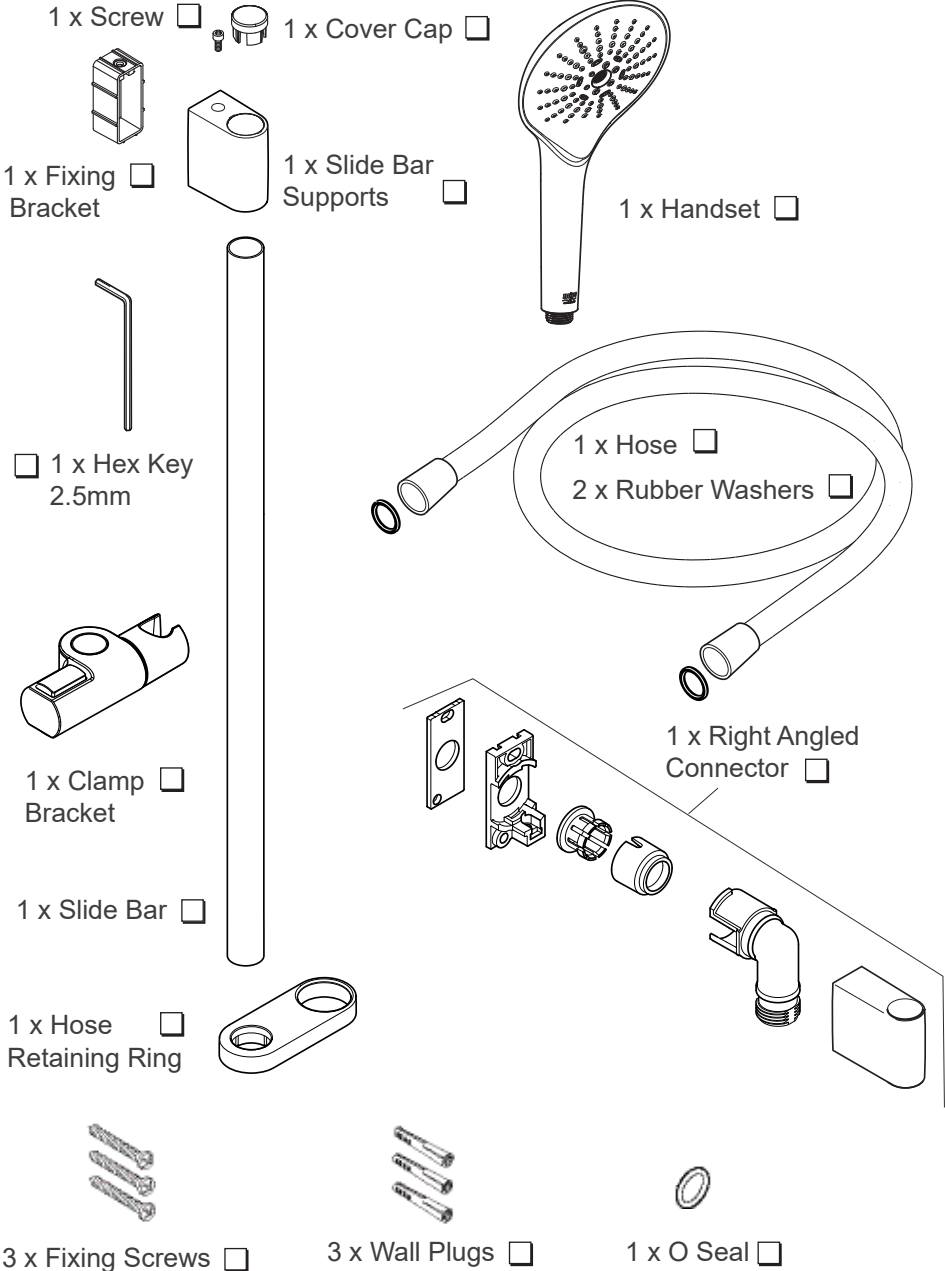

Interface

Important! Some parts may differ from the below depending on product purchased.

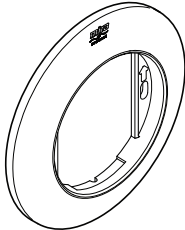

1 x Backplate

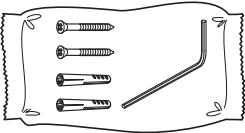

1 x Component Pack
(Includes 1.5mm hex key)

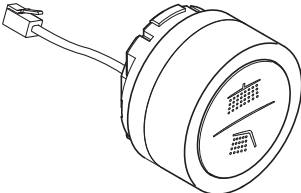

1 x Interface

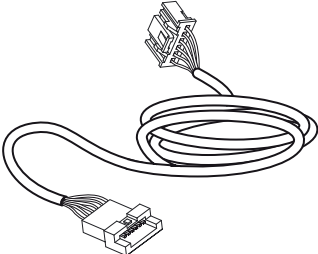

1 x Interface Lead

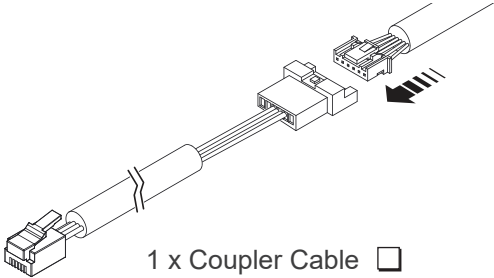

1 x Coupler Cable

Ceiling-Fed Deluge Head

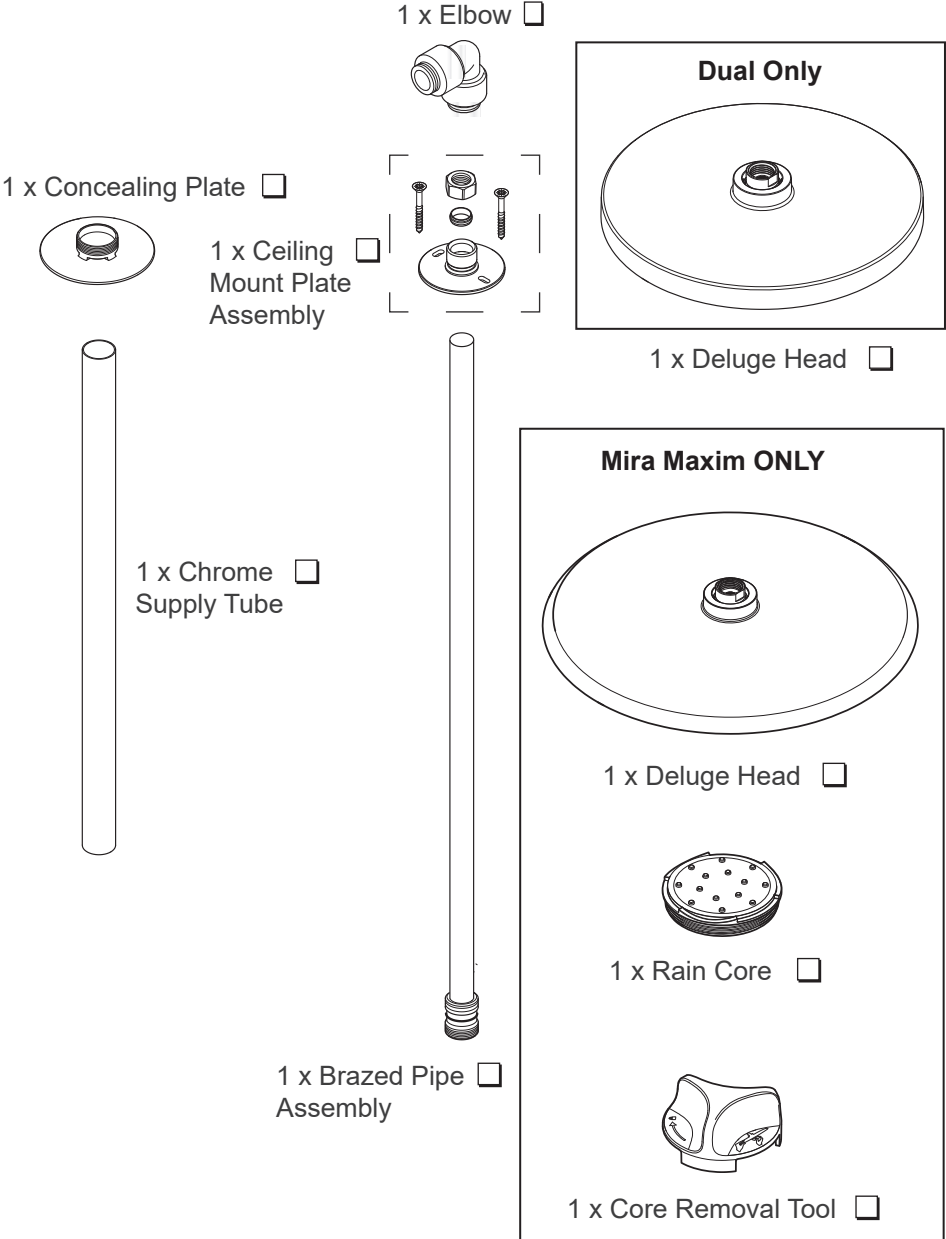

Rear Fed Shower Arm and Deluge Head

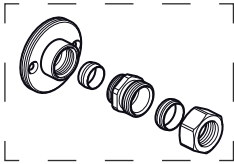
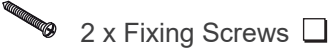
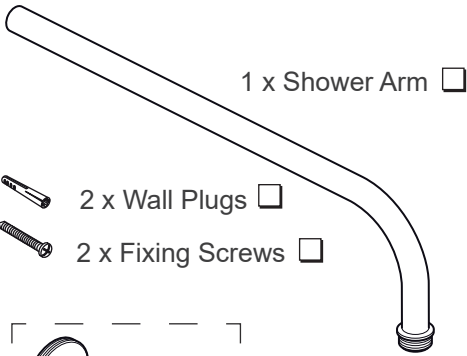

1 x Backplate Assembly

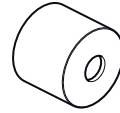

1 x Concealing Shroud

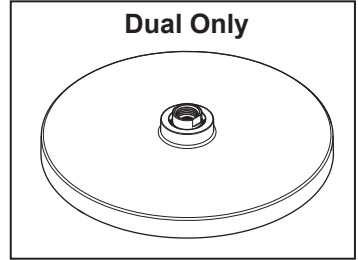

1 x Deluge Head

Bath Filler

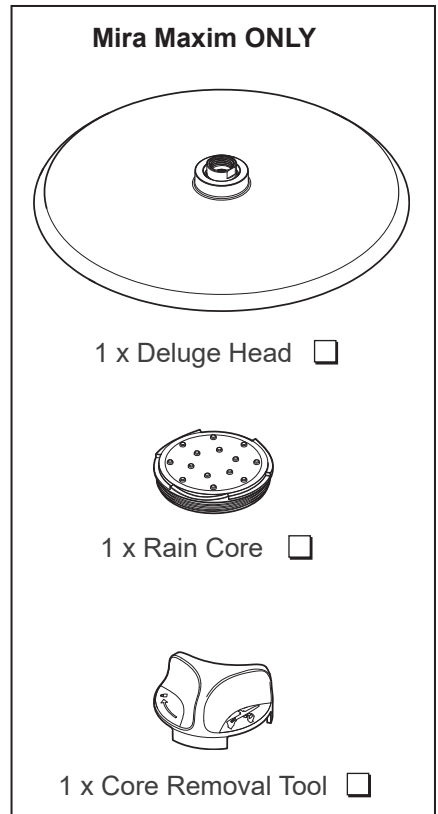
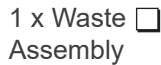
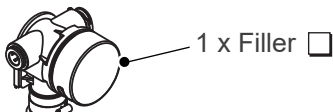

1 x Deluge Head

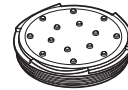

1 x Rain Core

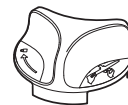

1 x Core Removal Tool

Guarantee

The Mira Mode has been designed for domestic use only, it is not recommended for Commercial or Healthcare use. For domestic installations, Kohler Mira Ltd. guarantee the Mira Mode against any defect in materials or workmanship for a period of five years from the date of purchase (shower fittings for one year).

For non-domestic installations, Kohler Mira Ltd. guarantee the Mira Mode against any defect in materials or workmanship for a period of one year from the date of purchase.

Your guarantee is only valid if you follow the guidance within this installation and user guide, including the ‘Cleaning and Maintenance’ and ‘General Installation’ section. See the back page of this guide for more information.

Recommended Usage

Domestic	✓	Light Commercial	✗
Heavy Commercial	✗	Healthcare	✗

Products Covered

Product Name	Product No.	Product Code	Type 2 Designation
Mira Mode Rear Fed Shower (High Pressure / Combi)	1.1980.001	N90AMr	HP-S
Mira Mode Rear Fed Shower (Pumped)	1.1980.002	N90FMr	LP-S
Mira Mode Ceiling Fed Shower (High Pressure / Combi)	1.1980.003	N90AMc	HP-S
Mira Mode Ceiling Fed Shower (Pumped)	1.1980.004	N90FMc	LP-S
Mira Mode Dual Rear Fed Shower (High Pressure / Combi)	1.1980.005	N90BMr	HP-S
Mira Mode Dual Rear Fed Shower (Pumped)	1.1980.006	N90GMr	LP-S
Mira Mode Dual Ceiling Fed Shower (High Pressure / Combi)	1.1980.007	N90BMc	HP-S
Mira Mode Dual Ceiling Fed Shower (Pumped)	1.1980.008	N90GMc	LP-S
Mira Mode Bath (High Pressure / Combi)	1.1980.009	N90AMb	HP-T44
Mira Mode Bath (Pumped)	1.1980.010	N90FMb	-
Mira Mode Dual Bath / Shower (High Pressure / Combi)	1.1980.011	N90BMb	HP-S
Mira Mode Dual Bath / Shower (Pumped)	1.1980.012	N90GMb	LP-S
Mira Mode Maxim Rear Fed (High Pressure / Combi)	1.1980.013	N90BMrm	HP-S
Mira Mode Maxim Rear Fed (Pumped)	1.1980.014	N90GMrm	LP-S
Mira Mode Maxim Ceiling Fed (High Pressure / Combi)	1.1980.015	N90BMcm	HP-S
Mira Mode Maxim Ceiling Fed (Pumped)	1.1980.016	N90GMcm	LP-S

Patents and Design Registration

Granted Patents:	GB2568271B, GB2579960B, GB2549971B
Granted Design Registrations:	90027795380003, 90027795380002, 90031549390001, 90031549390002, 90031549390003, 90031549390004, 90031549390005

Specifications

Standards and Approvals

The Mira Mode complies with all applicable UK & EU regulations & directives. The Mira Mode is a type 1 electronic, independently mounted control for surface mounting. Mira Mode is a thermostatic water mixing valve.

The digital valve is equipped with Bluetooth® wireless technology. The Bluetooth® word mark and logos are registered trademarks owned by the Bluetooth SIG, Inc. and any use of such marks by Kohler Mira Ltd is under license. Other trademarks and trade names are those of their respective owners.

General	
Pollution Degree	2
Rated Impulse Voltage	2.5 kV
Connections	15mm pushfit
Suitability for Drinking Water Applications	Not suitable
Solenoid Type	Pilot operated
Water Connection Type	Permanent

Mira Digital Mixing Valve High Pressure/Combi (not suitable for pumped gravity systems)

Pressures	
Thermostatic Standard	TMV 2 - HP-S (BS EN 1111 Type 2)
Maximum Static Pressure	1000 kPa (10 bar)
Maximum Maintained Pressure	500 kPa (5 bar)
Minimum Maintained Pressure	100 kPa (1 bar)
Supply Pressure Differential	Nominally equal
Temperatures	
Maximum Temperature (setting range)	30°C - 48°C (Factory Preset 45°C)
Minimum Temperature	Thermostatic control down to 30°C Full Cold also selectable
Hot Water Range - Supply	55°C - 65°C
Cold Water Range - Supply	1°C - 20°C
Temperature Stability at Valve Outlet	± 1°C at recommended supply conditions
Ambient Temperature	1°C - 50°C
Maximum Relative Humidity	95% non-condensing at 30°C
Electrical Rating	
Supply Voltage	100V - 240V AC 50/60Hz
Maximum Load	38W
Output Supply Voltage to Valve	12V DC

Flow Rates	
Nominal Flow Rate	<p>Minimum flow rate - 4 L/min</p> <p>Under ideal system conditions:</p> <p>Handset products can deliver up to 10 L/min at 1 bar maintained pressure*</p> <p>Overhead products can deliver up to 16 L/min at 1 bar maintained pressure*</p> <p>Default flow rate target: 12 L/min (showering products), 16 L/min (bath filler products).</p> <p>Maximum settable flow rate target: 16 L/min</p>

Mira Digital Mixing Valve Pumped/Gravity (not suitable for mains pressure systems)

Caution! The pump in this product is not suitable for dry running. It is essential you follow the commissioning sequence detailed in this guide.

Pressures	
Thermostatic Standard	TMV 2 - LP-S (BS EN 1287 Type 2)
Maximum Static Pressure	100 kPa (1 bar) 10m head
Maximum Maintained Pressure	100 kPa (1 bar) 10m head
Minimum Maintained Pressure	1 kPa (0.01 bar) 0.10m
Supply Pressure Differential	Nominally equal
Temperatures	
Maximum Temperature (setting range)	30°C - 48°C (Factory Preset 45°C)
Minimum Temperature	Thermostatic control down to 30°C Full Cold also selectable
Hot Water Range - Supply	55°C - 65°C
Cold Water Range - Supply	1°C - 20°C
Temperature Stability at Valve Outlet	± 1°C at recommended supply conditions
Ambient Temperature	1°C - 50°C
Maximum Relative Humidity	95% non-condensing at 30°C
Flow Rates	
Nominal Flow Rate	<p>Minimum flow rate - 4 L/min</p> <p>Under ideal system conditions:</p> <p>Handset products can deliver up to 10 L/min at 0.1 bar maintained pressure*</p> <p>Overhead products can deliver up to 12 L/min at 0.1 bar maintained pressure*</p> <p>Default flow rate target: 12 L/min (showering products), 16 L/min (bath filler products).</p>

Electrical Rating	
Supply Voltage	100V - 240V AC 50/60Hz
Maximum Load	80W
Output Supply Voltage to Valve	12V DC & 24V DC

***Note: Maintained (or dynamic) pressure is the pressure at the valve inlets during operation. Some installations will see a significant pressure drop in the supply pipework when water is flowing, especially when long plastic pipework and small bore fittings are used.**

It is recommended to keep supply pipework as short as possible, avoid unnecessary bends and minimise the number of fittings that are used. For longer pipe runs, it may be necessary to increase the nominal pipe size to reduce the pressure drop. Consult a plumbing professional if you are unsure.

If your plumbing system cannot maintain the minimum specified pressure at the valve inlets, you will not be able to achieve the flow rates specified, even if you increase the flow rate target of the product.

Note: Valves operating outside of the manufacturers recommended conditions of use cannot be guaranteed to operate as TMV2 Type 2 valves.

User Control

Electrical Supply	12V DC SELV 2W Max
Ingress Protection	IP X4
Maximum Ambient Temperature	40°C

Plumbing Connections

Use below pipework size and type to make connections as listed.

Warning! Use of incorrect pipe types or sizes may cause leaks. Supplied connectors are NOT suitable for 1/2" Pipework. You must use appropriate adapters (not supplied) for 1/2" pipework.

Valve Inlet	15mm Push Fit Plastic (Push Fit Isolator supplied)
Valve Outlet	15mm Push Fit - see below (Straight connector supplied)
Overhead (Ceiling Fed or Rear Fed)	15mm Copper
Handset Supply Pipe (Ceiling Fed)	15mm Push Fit Plastic or Copper (Elbow Supplied)
Right Angled Connector (Rear Fed)	15mm Copper
Bathfiller	15mm Copper
Bathfiller Waste (Trap Connection)	1-1/2" (Not supplied)

Suitable Plumbing Installations

Digital Mixing Valve (High Pressure/Combi Models)

1. Combination boiler systems - the digital high pressure/combi shower can be installed with an instantaneous combination boiler.
2. Unvented mains pressurised system - the digital high pressure/combi shower can be installed with an unvented, stored hot water cylinder system.
3. Mains pressurised instantaneous hot water heater - the digital high pressure/combi shower can be installed with systems of this type with balanced pressures.

Caution! High pressure mixing valves must never be plumbed to gravity or pumped gravity systems. This includes mixed gravity and mains pressure e.g. gravity hot and mains cold. Doing so will invalidate the warranty and potentially cause product and property damage.

Use of Warm-up Feature with Combination Boilers

When using the warm-up feature (see User Guide) with the digital mixing valve supplied via an instantaneous water heater/combination boiler, the user may experience a brief temperature fluctuation. This is caused by the normal operation of a standard instantaneous water heater/combination boiler whereby the boiler will turn off when the flow is stopped (as happens after the warm-up sequence has been completed). Upon restart of the shower, a cold shot will be flushed through followed by a brief hot shot until the hot water supply has stabilised.

Digital Mixing Valve (Pumped/Gravity Models)

Gravity fed hot water systems

Caution! Digital pumped/gravity valves must never be plumbed to mains pressure systems. This includes mixed gravity fed and mains pressure e.g. gravity hot and mains cold. Doing so will invalidate the warranty and potentially cause product and property damage.

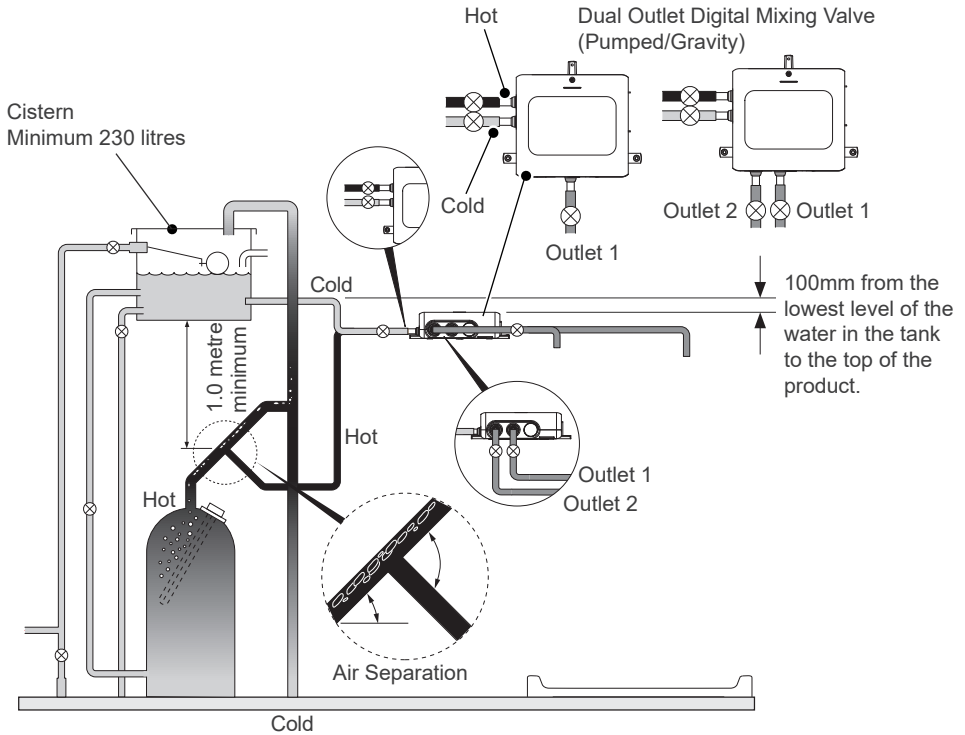

The shower control must be fed from a cold water storage cistern and a hot water cylinder providing nominally equal pressures. Pipework layouts and connections must be such that other draw-offs will not affect water supplies to the shower, shared supplies may lead to airlocking or water starvation. It is therefore best practice to have independent hot and cold supplies to the digital mixing valve pumped/gravity.

Showering Maximum Flow Rate

Combination Boilers

Note: The digital mixing valve can demand hot water quicker than some instantaneous water heaters/combination boilers can provide, especially in winter when the mains water is colder. It is therefore possible this mixing valve will need to have its outlet flow rate altered to match the capability of the water system.

The outlet flow rate can be altered by use of the Mira Showers app.*

High flow rate demanded from low kW combination boilers will result in poor blend temperature stability and could result in your shower going cold. We strongly recommend you to alter the outlet flow rate as the table below.

Boiler Rating	24kW (80,000 Btu/h)	30kW (100,000 Btu/h)	36kW (120,000 Btu/h)
Outlet Flow Rate	8 L/min	10 L/min	12 L/min

Gravity System

A gravity fed hot water cylinder has a finite amount of stored hot water. A standard size hot water cylinder, e.g. 230 Litres, with stored water heated to 65°C will typically provide a showering duration of 30 minutes when the shower temperature is set to mid-blend (approximately 40°C) and at a flow rate of 9 L/min. With the flow rate set to 12 L/min it will reduce the total showering duration to typically 20 minutes.

Once the stored hot water has been depleted, sufficient time will be required for the hot water cylinder to reheat its stored water supply before additional showering time can take place.

The outlet flow rate can be altered by use of the Mira Showers app.*

It may be necessary to alter the outlet flow rate using the Mira Showers app if your stored hot water is running out too quickly.

***Note: If your water system is not capable of delivering minimum maintained pressure at the valve inlets, you will not be able to achieve the maximum flow rate from your shower even if adjusted via the Mira Showers app. Ensure you have the minimum required maintained pressure at the valve inlets before installation.**

Installation Schematic

Mira Mode Dual Ceiling Fed Shower

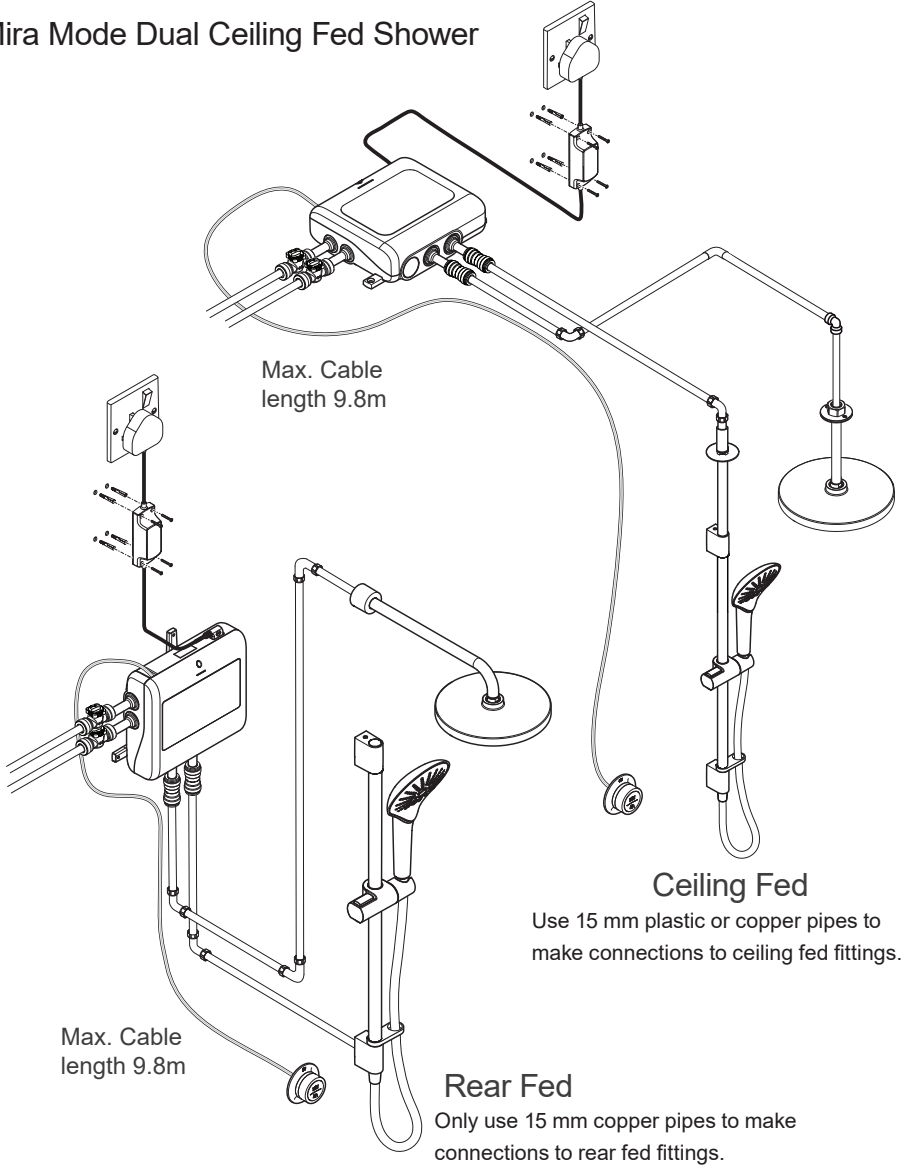

Product Name	Outlet 2 (left hand outlet)	Outlet 1 (right hand outlet)
Mira Mode Single Outlet Product	Not Applicable	Handset/Overhead/Bath filler
Mira Mode Dual Outlet Product	Overhead	Handset

Mira Mode Dual Bath / Shower

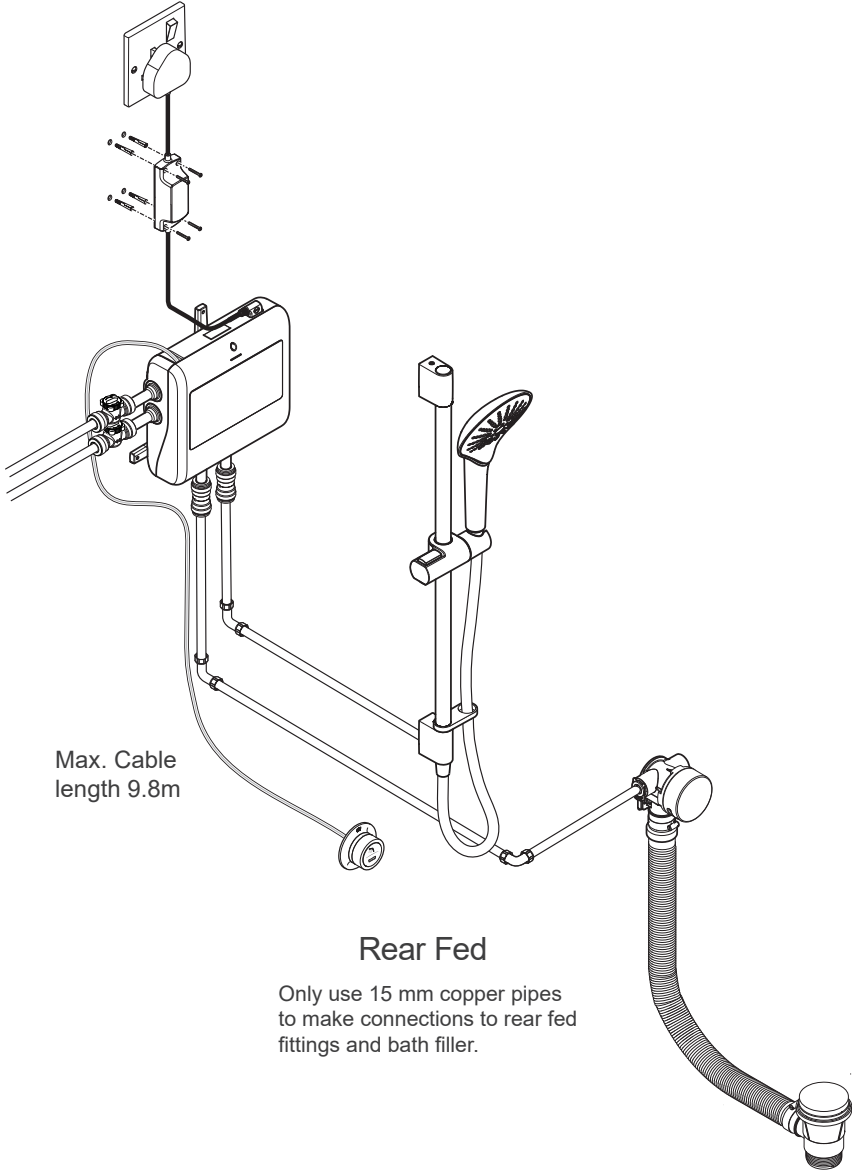

Product Name	Outlet 2 (left hand outlet)	Outlet 1 (right hand outlet)
Mira Mode Dual Bath/Shower Product	Bath filler	Handset

General Installation

All installations shall comply with the Water Supply (Water Fittings) Regulations 1999, Water Supply (Water Fittings) Regulations (Northern Ireland) 2009, and The Water Supply (Water Fittings) (Scotland) Byelaws 2014.

Safe and easy access to the product should be available at all times.

When installing the product in an area not regularly accessed, consideration for potential leaks must be taken into account. While such events are unlikely, it is advisable to periodically check the installation for traces of water on or around the product.

If possible, site the product in a location where any leak would be contained or routed to avoid areas sensitive to water damage.

Isolating valves must be installed to both inlets (supplied) and it is recommended to fit isolators on the outlet, close to the digital mixing valve for ease of maintenance.

The water supplies to this product must be isolated if the product is not to be used for a long period of time. If the product or pipework is at risk of freezing during this period they should also be drained of water.

Important Installation Considerations

- **DO NOT** site the digital valve where it may freeze, this may cause internal damage and risk a major water leak after thawing.
- Ensure the valve is sited in an area where it meets an ambient temperature between 1°C and 50°C all year round. If fitted in a loft space, consideration must be made to site away from freezing airflow e.g. not sited against outside wall, close to eaves or in an exposed roof.
- Remove any loft insulation directly below valve to allow warm air to rise from property below and fully lag all exposed pipework. Advise the homeowner where the digital valve is sited for future reference.
- Ensure pumped/gravity digital mixing valves showers are not connected to any mains water pressure e.g. stored gravity hot water and cold mains water.
- High pressure/combi digital mixing valves should not be fitted to a gravity or pumped gravity systems.
- The digital mixing valve should not be installed where it can become frozen or be subjected to ambient temperatures in excess of 50°C.
- **DO NOT** use any type of jointing paste or compound on any pipework or fittings supplying the digital shower valve. These can build up within the product and reduce the performance or cause early failure.
- Only use Ø15 mm pipe, **DO NOT** use any other pipe sizes as this may result in leaking. You **must** use appropriate adapters (not supplied) for 1/2" pipework.
- Position the digital mixing valve and power supply so that there is enough room for maintenance (e.g. removal of the valve lid and servicing filters through removing inlet pipework) and make sure safe and easy access is available at all times.

Caution! The inlet pipework must be flexible enough to allow 25 mm movement to enable filters to be removed for cleaning and for maintenance of the internal components.

Failure to achieve this may result in service and repair not being able to be carried out.

- Supply pipework layout must be arranged to minimize the effect of other outlet usage as shared water supplies may reduce its flow performance upon the dynamic pressures at the digital mixing valve inlets.

- Avoid installations where air locking could occur.
- Cold water cisterns should hold no less than 230 litres and hot water cylinders no less than 210 litres (gravity system only).
- To eliminate pipe debris, it is essential that water supply pipes must be flushed prior to connecting the digital mixing valve to the system so debris cannot enter the digital mixing valve internals.
- Fully commission the product after installation taking care to look for any leaks and correct operation. For pumped product, follow commissioning instructions.
- The use of supply-line or zone strainers will reduce the need to remove debris at the digital mixing valve. The recommended maximum mesh aperture dimension for such strainers is 0.5mm.
- Pipework must be rigidly supported and routed such that it does not cause any strain on the connectors.
- Long outlet pipework (dead-legs) should be kept to a minimum to avoid temperature fluctuations.
- Cables routed through wall cavities, chased into solid walls, directed under baths or in loft spaces must be fitted in such a way that they can later be removed. To facilitate this appropriate cable conduit/trunking must be used at all times. The conduit/trunking must be at least 20mm diameter/square to allow for the safe removal of the connectors. Failure to do so may result in an inability to carry out any maintenance or servicing. Safe and easy access to the product should be available at all times.
- The product has integral check valves for the purpose of backflow prevention. These can be replaced if required by following the instructions at the end of this guide.
- **DO NOT** use handsets which have a pause function. Stop the water flow using the user controller.
- **Warning! Ensure use of correct pipe types and sizes. Use of different pipe sizes may cause leaks. See 15.**

Installation: Digital Mixing Valve

Caution! The digital mixing valve (which contains the thermostatic mixing valve) must be orientated in the positions shown below. Failure to do so will compromise the ability of the unit to fail-safe and deliver constant blend.

- 1 The digital mixing valve may be installed in a loft space, under the bath or in a convenient cupboard space, provided there is enough room for maintenance (e.g. removal of digital mixing valve lid and removal of the inlet pipework to access the inlet filters). Failure to do so may result in an inability to carry out any maintenance.

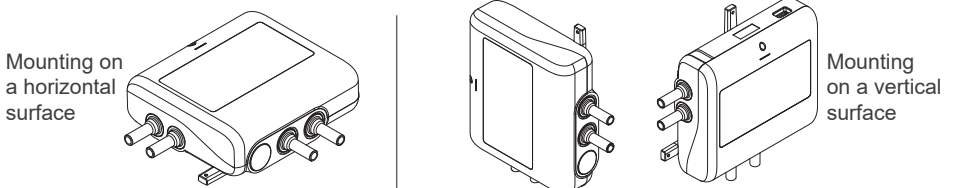

2 Important! Loft Installations - Risk of Freezing.

If installing the digital mixer in a loft space or an area where freezing may occur additional precautions **MUST** be taken to avoid freezing. Frozen valves are likely to experience internal damage and once thawed risk property flooding. Frozen valves and the consequences thereof, are not covered by the Guarantee.

- Ensure the valve is sited in an area where it meets an ambient temperature between 1°C and 50°C all year round. If fitted in a loft space, consideration must be made to site away from freezing airflow e.g. not sited against an outside wall, close to eaves or in an exposed roof.
- For loft installations the valve **MUST ONLY** be installed flat on a horizontal surface.
- Remove any loft insulation directly below valve to allow warm air to rise from property below.
- Insulate the digital valve with a minimum of 200 mm non-combustible insulation that meets a fire rating of **Euroclass A1 to BS EN 13501-1**.
- **DO NOT** use foil type loft insulation as this will inhibit Bluetooth and Wi-Fi signals, which will degrade the communication range between the digital valve, the user interface, and Mira app.
- **DO NOT** insulate the Power Supply Unit (PSU).
- Fully insulate all exposed pipework.
- Advise the homeowner where the digital valve and electrical/water isolation points are sited.

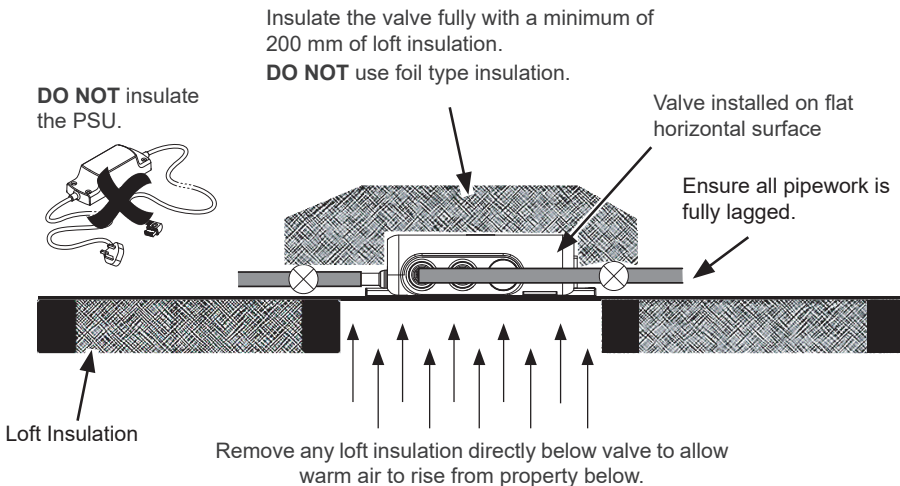

3 Fit the 2 feet in desired location on digital mixing valve using the two Torx 3.5 x 12mm screws supplied.

Note: There are 4 possible locations to install the feet, depending on your installation constraints.

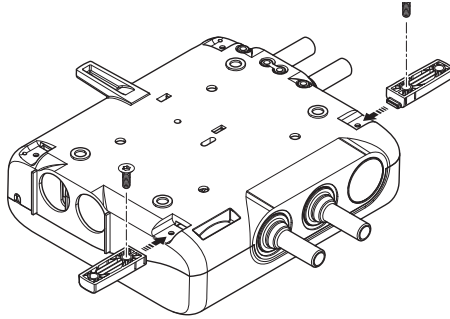

4 Mark the fixing holes in the required positions and secure using suitable fixings.

Note: The valve must be installed on a flat surface.

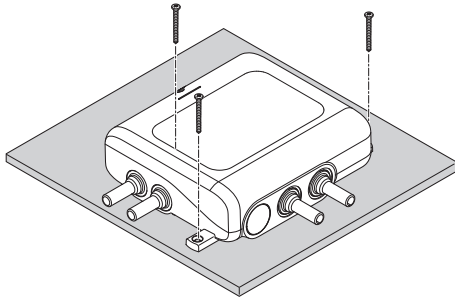

5

Connect the hot and cold inlet supply pipework to the digital mixing valve.

Note: DO NOT use any type of jointing paste or compound on any pipework or fittings supplying the digital shower valve. These can build up within the product and reduce the performance or cause early failure.

Note: Only use suitable 15mm pipework when connecting to the push-fit connectors. You must use appropriate adapters (not supplied) for 1/2" pipework. 15 mm plastic or copper pipework must be used as indicated in the 'Plumbing Connections Information' shown in the Specifications Section. Chromed copper, stainless steel or barrier pipe is not suitable for these push fit connectors.

Note: The inlet pipework must be flexible enough to allow 25 mm movement to enable filters to be removed for cleaning and for maintenance of the internal components. Failure to achieve this may result in service and repair not being able to be carried out.

Note: Flush pipework before connecting inlet pipes to digital mixing valve. Failure to flush pipework may cause debris to block filters and impair product performance.

Isolating valves must be installed to both inlets (supplied) and it is recommended to fit isolators on the outlet, close to the digital mixing valve for ease of maintenance.

Run the pipes from the mixed water outlets on the digital mixing valve to the proposed siting for the shower hose outlet, and overhead fixed arm, depending on the system chosen.

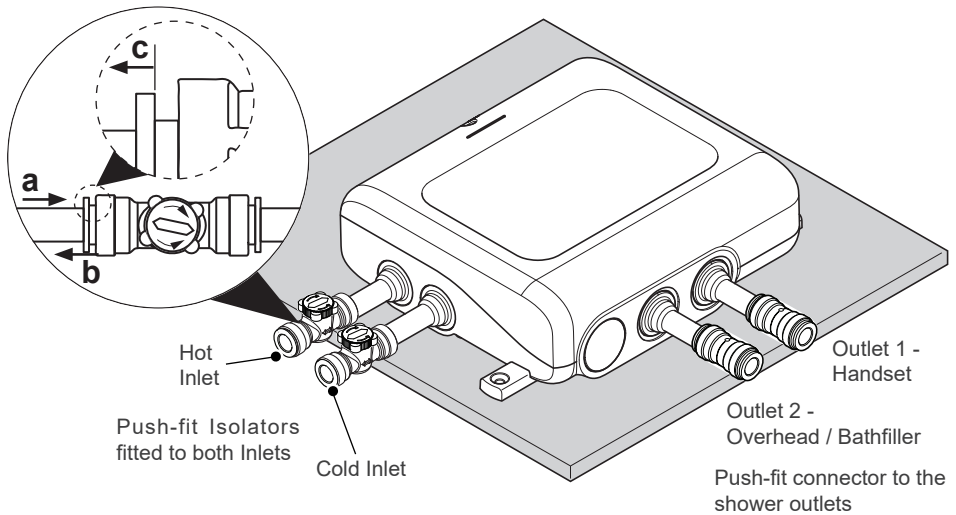

After installing the valve, check the push-fit connectors are correctly engaged.

- a. Ensure every pipe is fully pushed into the internal stop.
- b. Pull the pipework to ensure it is retained and locked in place.
- c. Ensure every locking ring is fully retracted.

6 Install the power supply unit provided, connecting it to the mains socket in accordance with the wiring regulations and permanently fix in place using suitable screws.

Connect the power supply cable to the digital mixing valve and ensure it is firmly in place.

Caution! Before any electrical adjustment is attempted, the electricity supply must be turned off at the mains switch.

Electrical installation may only be carried out by a competent person.

Electrical socket must be easily accessible for maintenance and service.

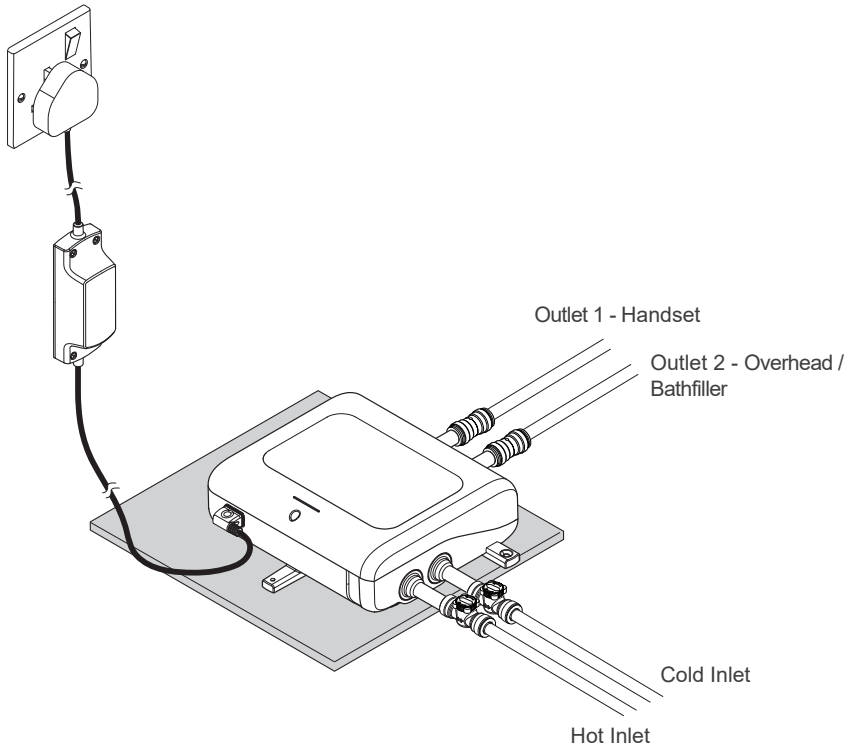

Note: This completes the initial installation of the mixing valve. Complete the shower fittings installation then go to commissioning section.

Note: If installing the Rear Fed Shower Fittings, continue steps from 34.

Note: If installing only Bath Filler, continue steps from 41.

Installation: Ceiling Fed Shower Fittings

Fix at convenient height for all the family. Position the fittings so that water sprays down the centre of the bath, or away from the opening of a shower cubicle. Water should spray away from the user controller when the handshower is held on the slide bar.

1 Mark the positions of the fixing holes for the slide bar.

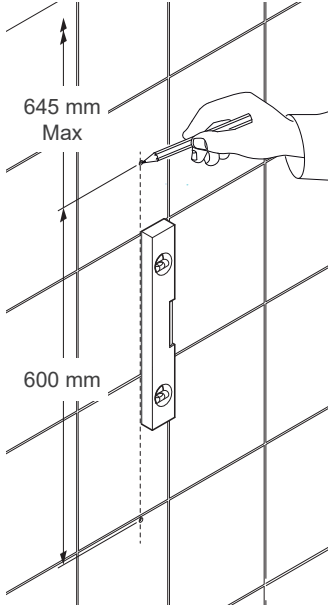
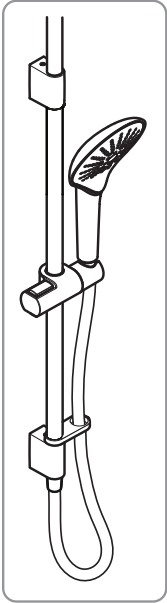

2 Mark the position of the hole on the ceiling. Cut the hole in the ceiling to a diameter of 29 mm.

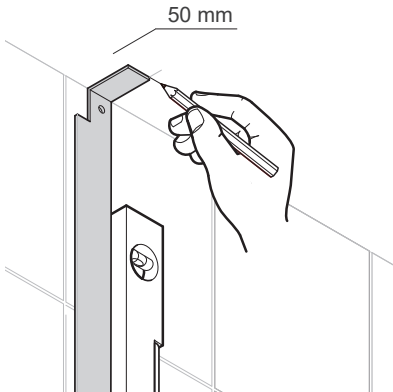

3 Drill the fixing holes in the wall. Fit the wall plugs and the fixing brackets.

Important! If supplied slide bar spacers are required, centre distance for ceiling hole will increase to 75 mm from wall. Use longer fixing screws if you are using the spacers.

Fit all the components onto the slide bar and install the slide bar assembly to the wall.

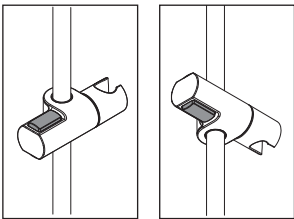
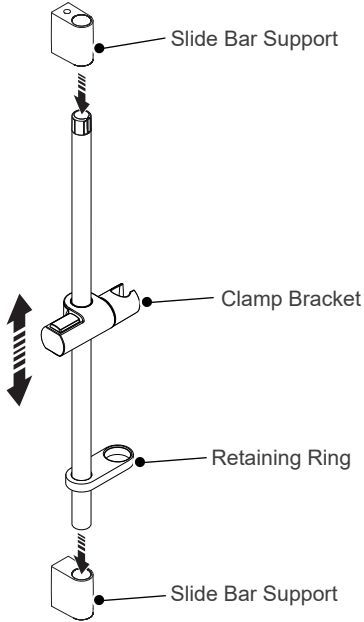

Important! Press the buttons on the clamp bracket to slide it through the slide bar.

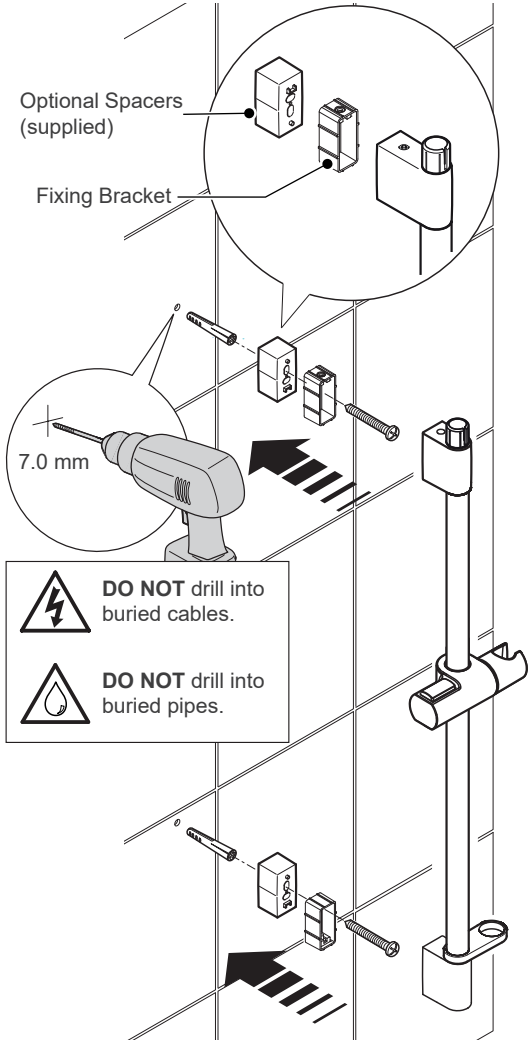

- 4** Install the screws top and bottom to secure the slide bar in position using a 3mm hex key.

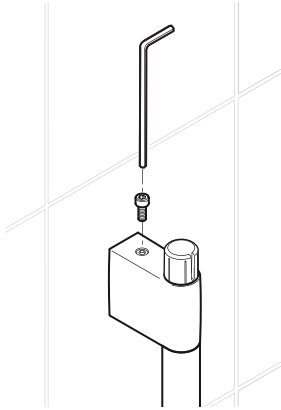

- 5** Install the falling supply tube.

Note: The falling supply tube may need to be shortened, use a hacksaw to shorten tube. Make sure the rough end is concealed in the ceiling.

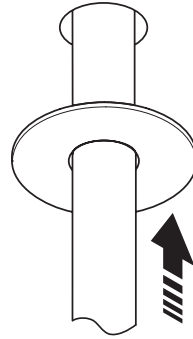

- 6**
- Feed the plastic tube up through the slide bar and into the ceiling.
 - Push and twist plastic pipe end until it “clicks” and locks in place.
 - Connect the elbow (supplied) onto the end of the plastic pipe. Push all parts together fully.

Caution! DO NOT allow any debris to block the plastic pipe.

Note: If plastic pipe requires shortening make sure there is enough length to fit elbow (supplied).

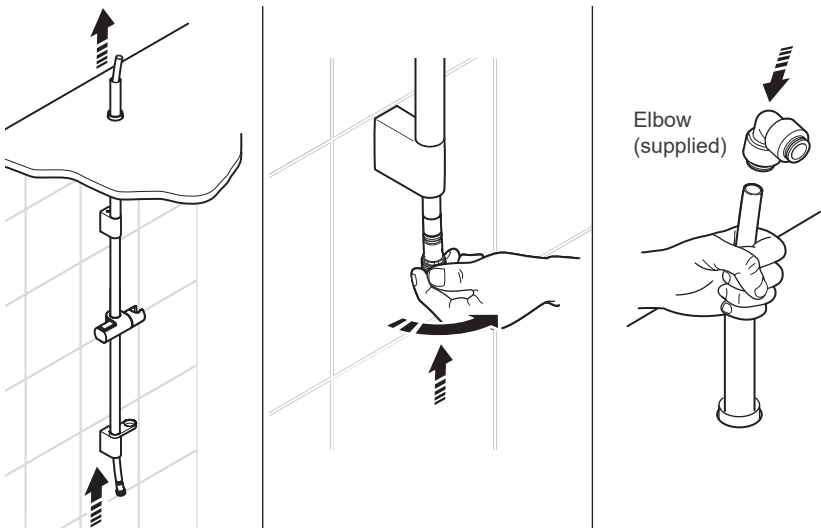

- 7** Connect the shower control outlet pipework to the elbow. (Pipe and isolating valve not supplied).

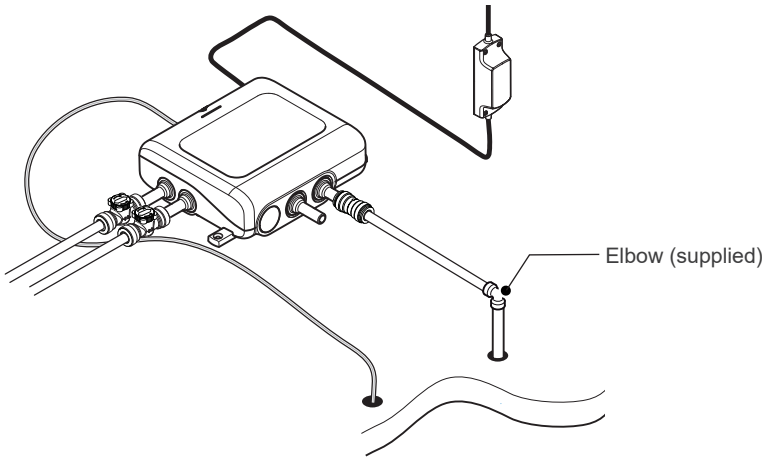

- 8** a. Fit the shower hose to the end of the slide bar assembly. Ensure the washer is in place in both ends of the hose.

Caution! DO NOT fit the handshower until after pipework has been fully flushed through. Refer to 'Commissioning'. See 47 for high pressure product, 49 for pumped product.

- b. Fit the shower hose to the handset. Make sure that you fit the washer into shower hose.

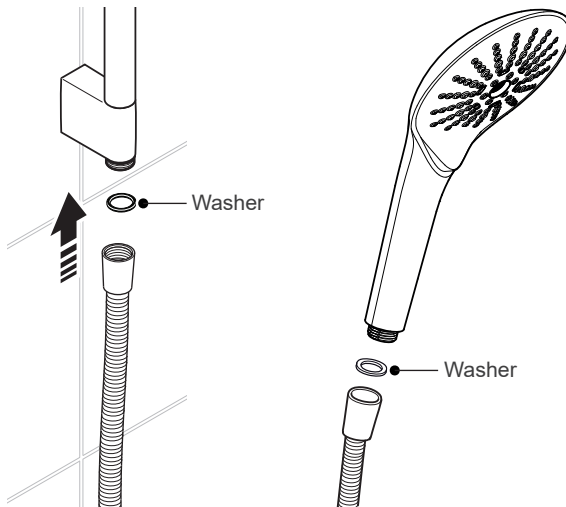

Installation: Ceiling Fed Deluge Head

Fix Deluge Head to the ceiling at a convenient height for all the family. Position so that water sprays down over the centre of the bath, or away from the opening of a shower cubicle. The fitting of the Deluge Head into the ceiling will be easier with two persons. When you are working within the bath or shower tray area use a towel or blanket to protect the surface from damage.

- 1 Decide on a suitable position for the Ceiling-Fed Arm avoiding cables and pipes hidden between joists or rafters.

Note: Make sure that the deluge head is not installed over the handshower.

Note: A timber noggin or plywood plinth securely fixed to the joist should be used to mount the Ceiling-Fed Arm.

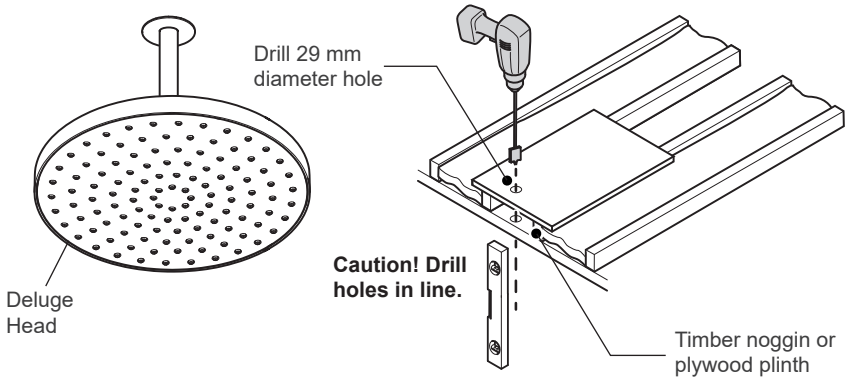

- 2 Push the brass pipe through the ceiling mount plate then push the threaded end of the brass pipe down through the hole made in the ceiling.

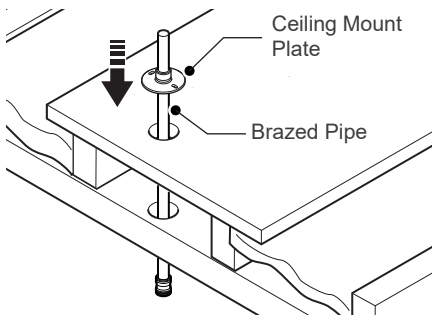

- 3 Centralise the brass pipe in the hole then screw the ceiling mount plate to the wooden support.

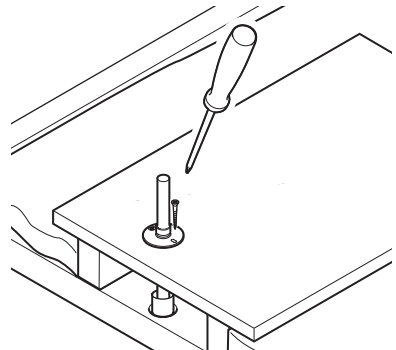

4 Offer the ceiling-fed arm to the brass pipe and determine the showering height required. Push or pull the brass pipe using a twisting motion to adjust the height. Check the height is correct and use a 15mm pipe cutter to cut the pipe to the desired length.

Note: Cut the brass pipe at least 75mm above the ceiling mount plate to allow room to fit the olive, nut and elbow.

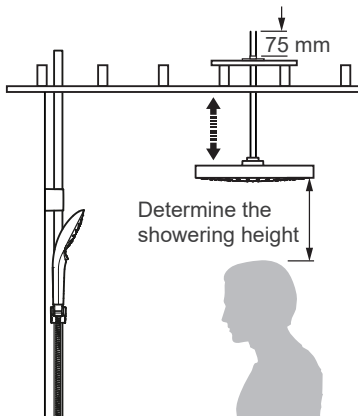

5 Secure the brass pipe to the ceiling mount plate with the olive and 1/2" BSP nut.

Note: This is not a water tight connection, tighten sufficiently to clamp the pipe in place.

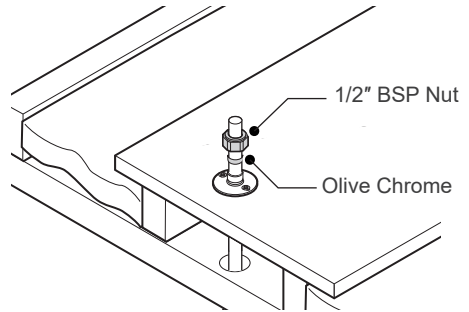

6 Offer the chrome shroud to the brass pipe and determine the length required to allow the shroud to conceal the brass pipe and protrude into the ceiling space a minimum of 15mm. Use a pipe cutter to cut the shroud to the desired length.

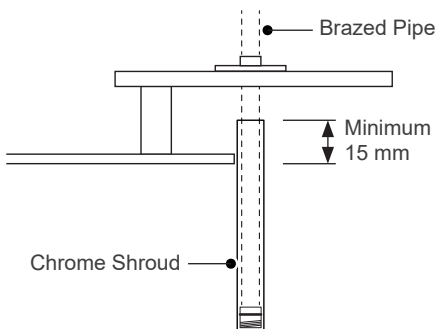

7 Push the chrome shroud into the ceiling plate then slide the chrome shroud over the threaded end of the brass pipe and up through the hole until the ceiling plate is secured in the hole and the ceiling plate is flat against the ceiling.

Note: If the hole in the ceiling is oversize use silicone on the underside of the ceiling plate to retain it.

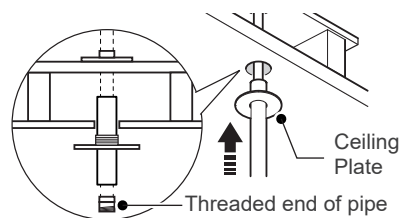

8 Connect the elbow (supplied) onto the end of the brass pipe. Push all parts together fully.

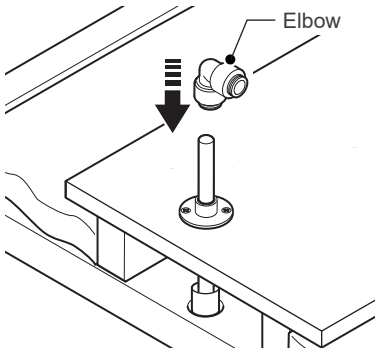

9 Connect the shower control outlet pipework to the elbow. (Pipes not supplied). Follow manufacturers guidelines for fitting flexible pipework.

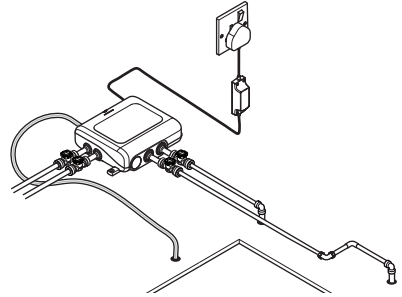

10 Ensure pipework is thoroughly flushed through before fitting the deluge head. Screw the fixed shower head onto the brass pipe outlet after commissioning has been completed.

Note: Use two suitably sized wrenches to tighten (approximately 1/4 turn).

Slide the chrome shroud down to conceal the brass pipe. Turn on the shower control and check for leaks.

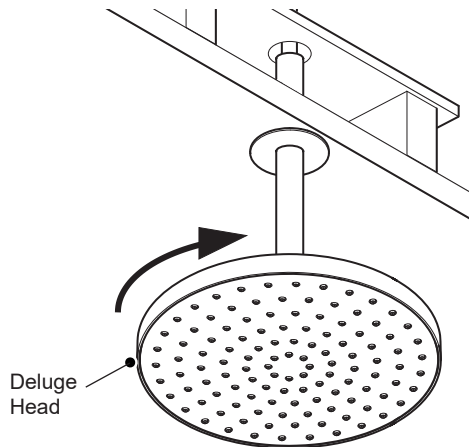

Installation: Rear Fed Shower Fittings

Suitable for solid, dry-lined, stud partition, shower cubicle or laminated panel walls. Plan installation location of the handshower and deluge showerhead before installing fittings kit.

Note: Make sure that the deluge head is not installed over the handshower.

Fix at convenient height for all users. Position so that water sprays down the centre of the bath, or away from the opening of a shower cubicle. Water should spray away from the Controller when the Handshower is held on the slide bar.

- 1 The right angle connector must be fitted to a waterproof, flat and even wall surface. The screws and wall plugs supplied are suitable for most solid wall installations. Alternative fixing screws for panel structures are not supplied. Use both fixing points to secure the right angle connector, be sure to use fixings appropriate for the chosen wall structure.

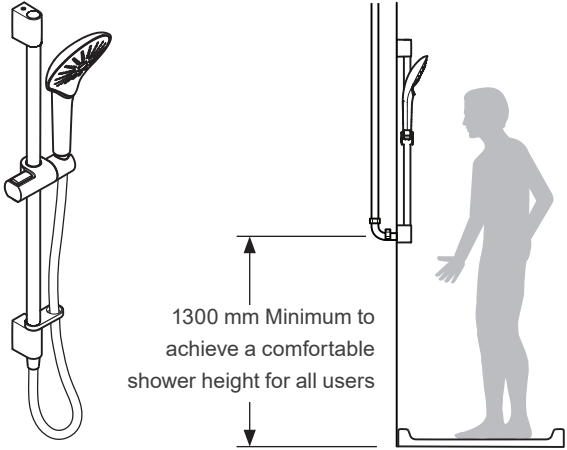

Using a suitable pipe cutter, trim the pipework back to the required depth from the finished wall surface. Remove all burrs and sharp edges.

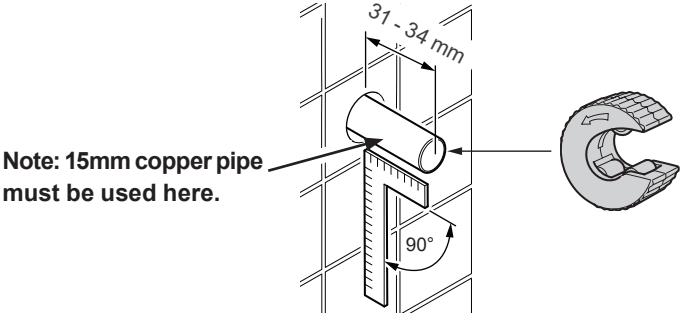

2 Mark the positions for the fixing holes for the right angled connector back plate.

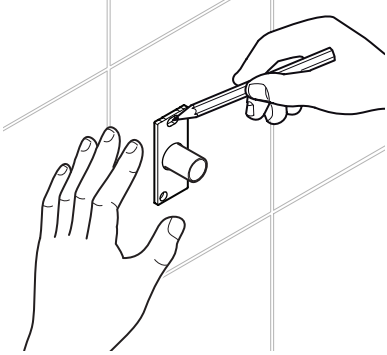

3 Drill the fixing holes, fit the wall plugs and secure the backplate to the wall with two fixing screws.

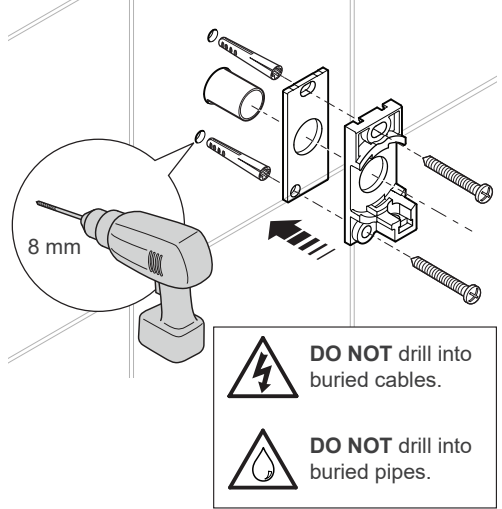

4 Secure the fixing parts onto the pipework.

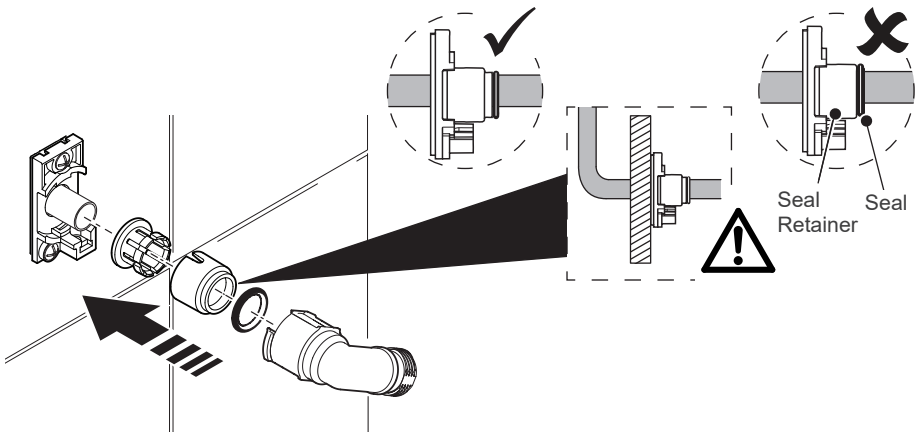

5 Rotate the elbow to lock into position.

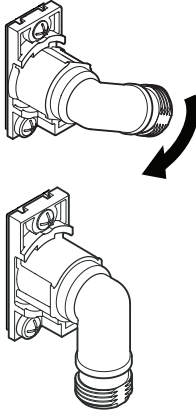

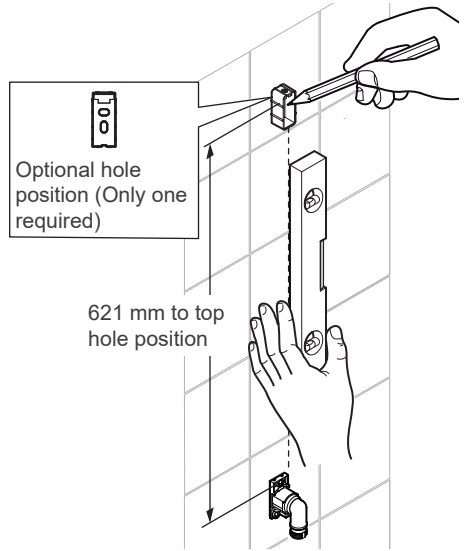

6 Temporarily hold the top support in position. Make sure that it is level and mark through the position of the fixing hole in the top support.

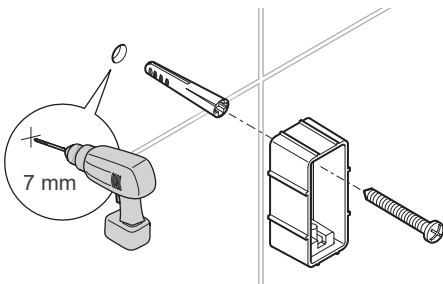

7 Drill the fixing hole for the top support and fit the wall plug



 **DO NOT** drill into buried cables.

 **DO NOT** drill into buried pipes.

8 Fit the cover over the elbow and use a 2.5mm hex key to tighten the screw anti-clockwise.

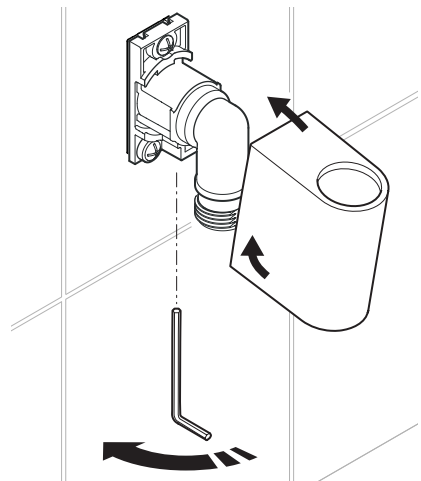

9

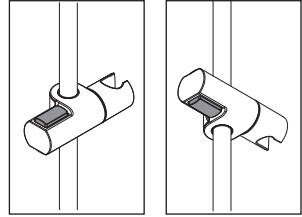
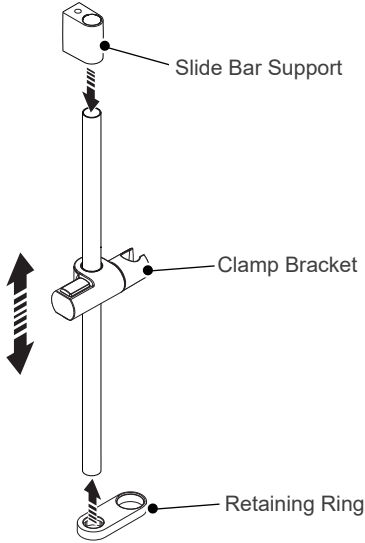
 Fit all the components onto the slide bar.

Important! Press the buttons on the clamp bracket to slide it through the slide bar.

10

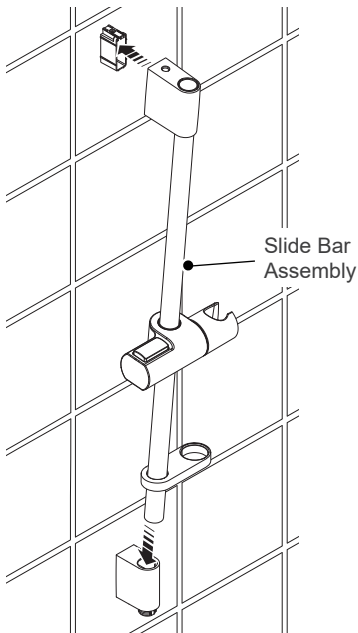
 Fix the slide bar assembly in position, making sure that it locates correctly.

11

 Carefully remove the slide bar assembly and tighten the screw on the back of the top bracket to secure in position.

Refit the slide bar assembly in position.

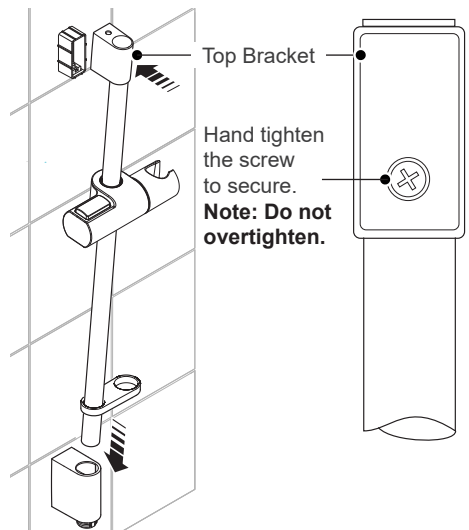

12 Secure the assembly in position with the screws using a 2.5mm hex key. The top securing screw tightens clockwise, the bottom one anti-clockwise. **DO NOT** overtighten.

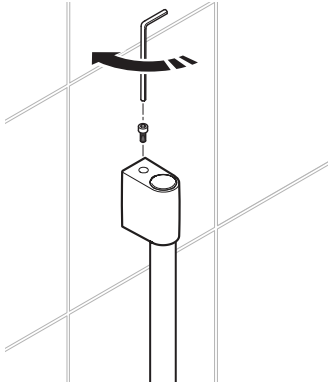

13 Fit the cap to the top of the side bar and fit the hose to the bottom outlet. Make sure that you fit the washer into shower hose.

Note: DO NOT fit the handshower until after pipework has been fully flushed through. Refer to 'Commissioning'. See 47 for high pressure product, 49 for pumped product.

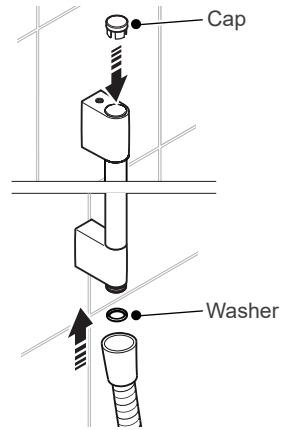

14 Fit the shower hose to the handset. Make sure that you fit the washer into shower hose.

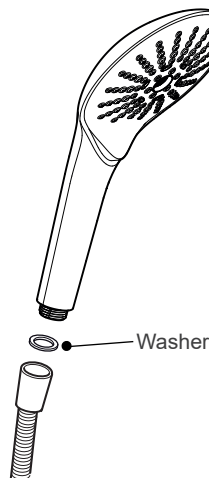

Installation: Rear Fed Deluge Head

Fix at convenient height for all users. Position so that water sprays down the centre of the bath, or away from the opening of a shower cubicle. Make sure that the water sprays away from the interface and the showerhead.

- 1** Note: Make sure that the deluge head is not installed over the handshower.

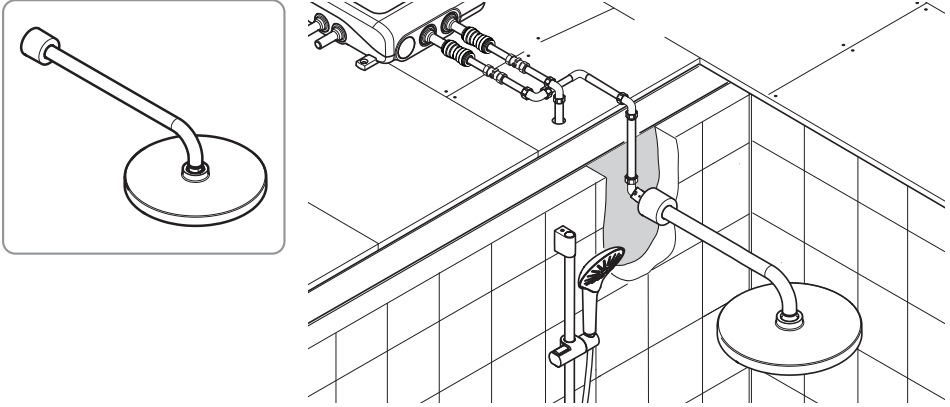

- 2** The outlet pipe must protrude 18 mm (± 2 mm) from the finished wall surface and a minimum 35 mm from the ceiling.

Note: Cut the pipe to the correct length and remove any burrs.

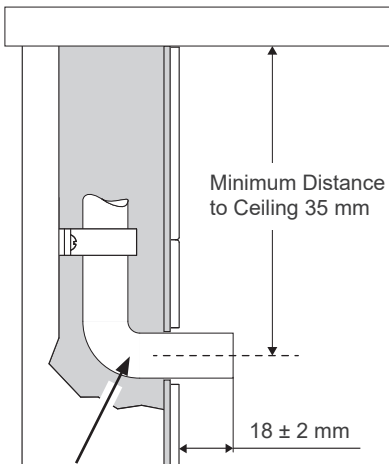

Note: 15mm copper pipe must be used here.

- 3** Mark the positions of the backplate fixing holes.

Caution! Be aware of hidden pipes or cables.

For solid walls drill the fixing holes for the backplate with a 6 mm drill and insert the wall plugs (supplied). For other types of wall structure alternative fixings may be required (not supplied).

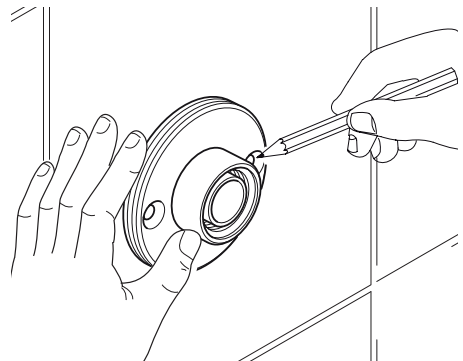

4 Carefully fit the backplate over the outlet pipe and secure with the fixing screws (supplied).

Caution! Take care not to damage the O Seal in the back of the backplate.

Fit the olive and compression nipple over the outlet pipe and tighten the compression nipple.

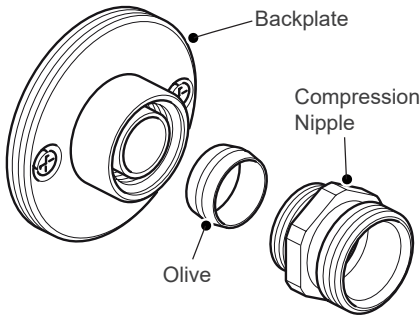

5 Fit the concealing shroud, the compression nut and the olive onto the shower arm.

Fit the shower arm into the compression nipple and tighten the compression nut.

Hand tighten the concealing shroud onto the backplate.

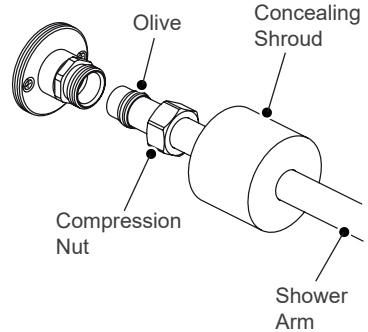

6 Ensure pipework is thoroughly flushed through before fitting the deluge head. Screw the fixed shower head onto the brass pipe outlet after commissioning has been completed.

Note: Use two suitably sized wrenches to tighten (approximately 1/4 turn).

On ceiling fed products, slide the chrome shroud down to conceal the brass pipe. Turn on the shower control and check for leaks.

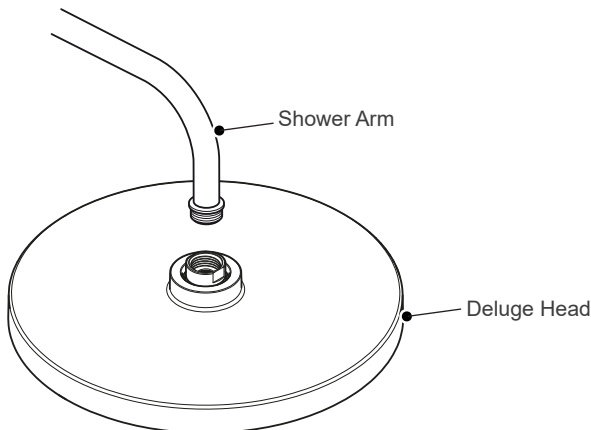

Installation: Bath Filler

1

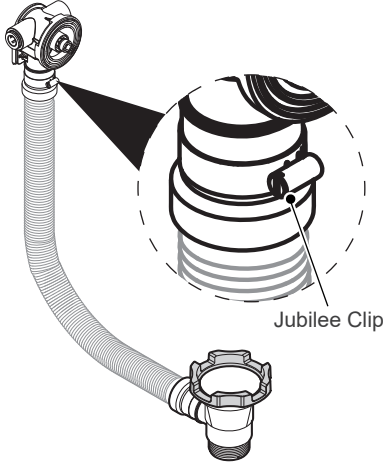

Note: When the bath filler waste is extended, there may be a need to rotate the bodies to allow alignment to the mating surface.

Refer below steps:

- Loosen the jubilee clip at the overflow end.
- Rotate the overflow body.

Carefully follow the below assembly drawings to install the overflow bath filler and waste.

2

Note: Ensure the screws are not cross threaded and are tightened evenly. Hand tighten only. **DO NOT** use a power driver to tighten the screws.

Important! When installing the Mixer Valve to be used as a bath filler ensure the flow rate of the bath overflow fitted exceeds the flow rate output from the Mixer Valve.

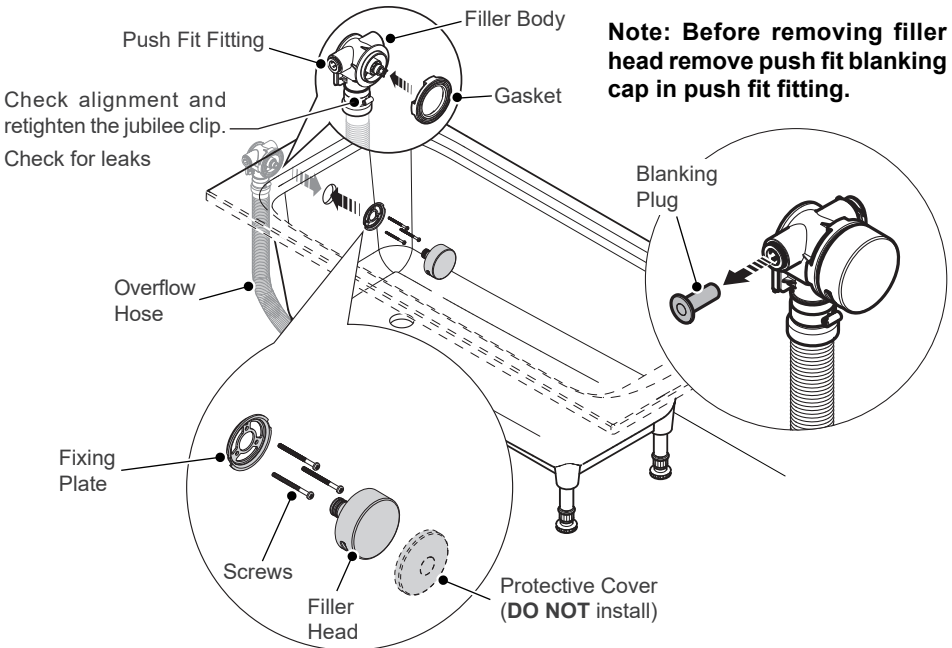

3 Turn anti-clockwise to remove the water stopper then remove the installation tool, then reassemble the water stopper to the waste body without the installation tool.

Note: An installation tool is supplied, this is stowed within the assembled waste body for packing purposes. Use this tool to screw the strainer into the waste body.

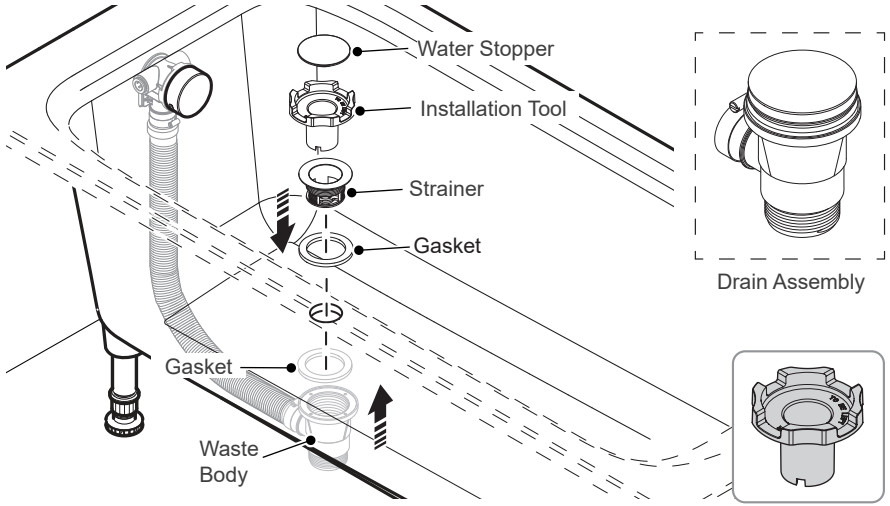

4

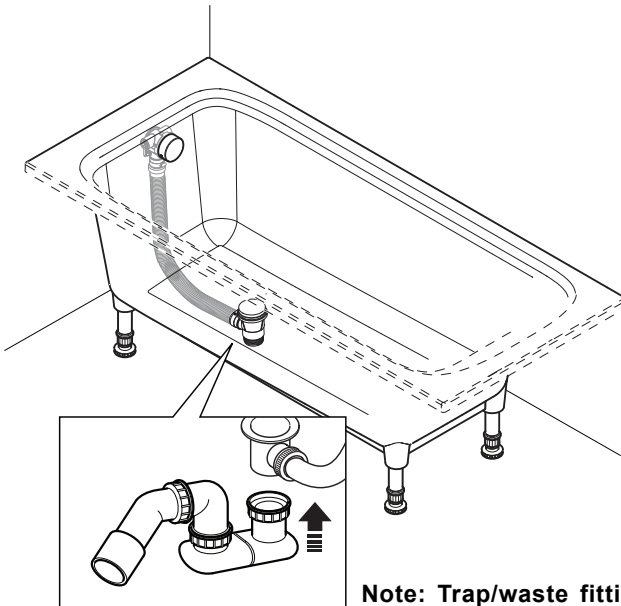

Note: Trap/waste fittings trap not supplied.

5

Push fit the water supply pipe to the bath filler using copper pipework (15mm diameter).

Note: Make sure that the pipe is pushed in fully (min 30mm) until it hits the internal stop feature.

Important! Cut the pipe using a pipe cutter only to ensure the seals are not damaged when the pipe is inserted. Remove all burrs.

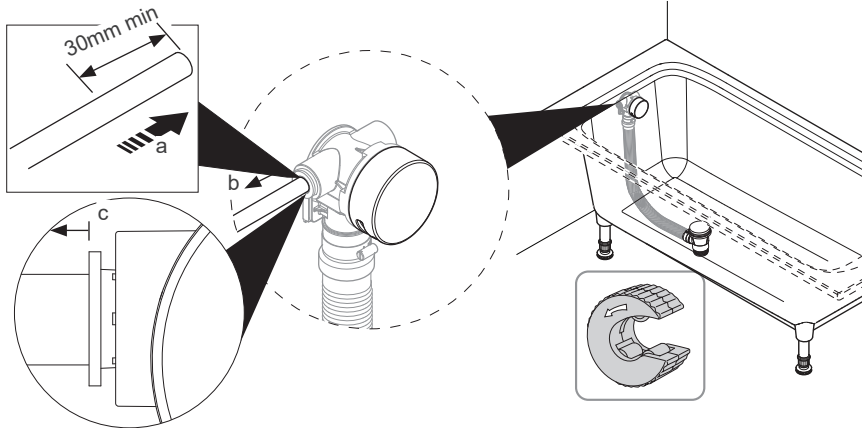

After installing the pipe, check the push-fit connector is correctly engaged.

- Ensure the pipe is fully pushed into the internal stop.
- Pull the pipework to ensure it is retained and locked in place.
- Ensure the locking ring is fully retracted.

6

Turn on the water supply and check for leaks from the waste and the bath filler connections. **Refer to 'Commissioning'. See 47 for high pressure product, 49 for pumped product.**

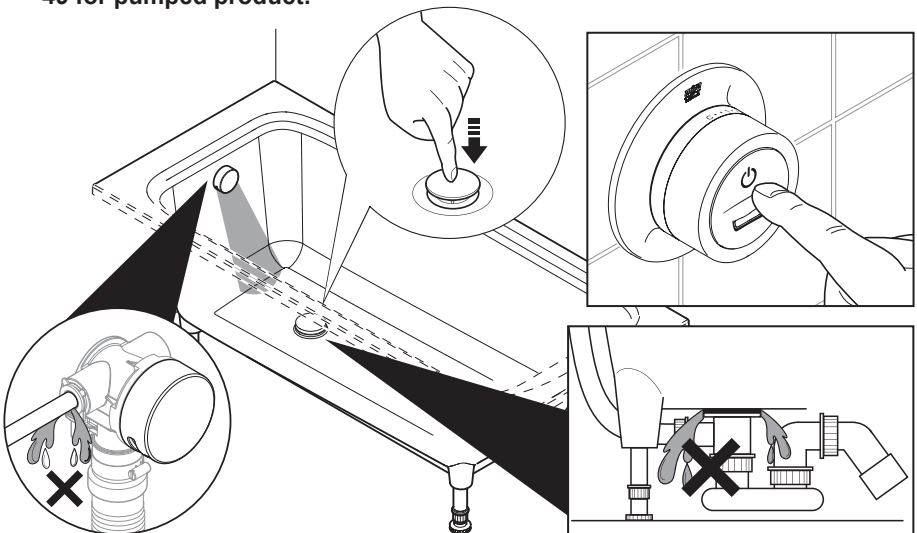

Installation: User Controller

- 1** Decide on a suitable position for the controller and mark the centre point on the wall. Using a level, mark the centre point for the 3 holes as shown below.

Note: The controller must be installed on a flat and even wall surface avoiding any grout lines.

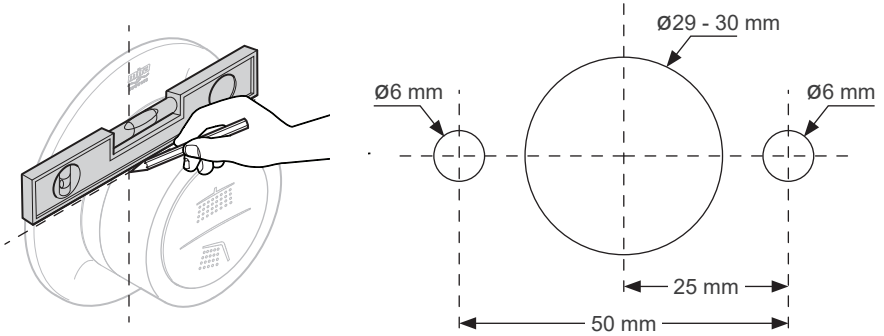

- 2** For solid walls drill the fixing holes for the backplate with a 6mm drill and insert the wall plugs (supplied). For other types of wall structure alternative fixings may be required (not supplied).

Using a suitable hole saw, drill the hole for the Controller cable as per the dimensions given. Route the cable from the digital valve through the wall.

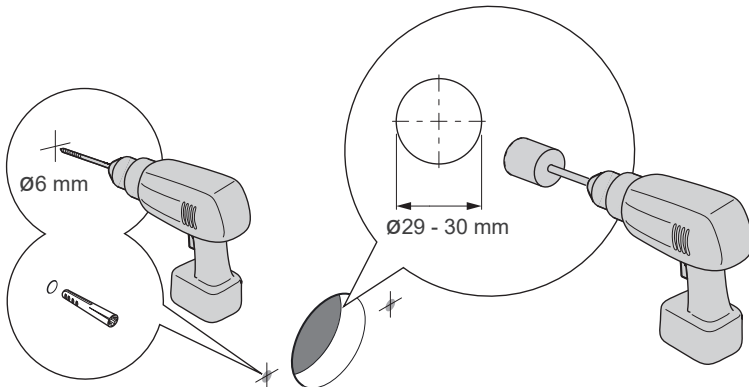

DO NOT drill into buried pipes.



DO NOT drill into buried cables.

- 3** Loosen the screw and remove the lid from the digital mixing valve using a pozi (PZ2) screwdriver.

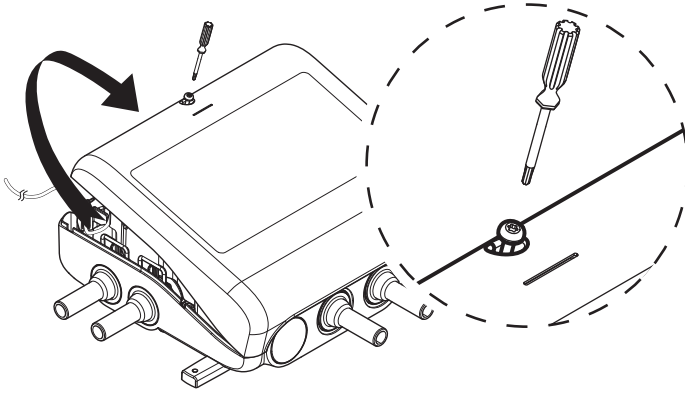

- 4** Connect the user coupler cable to digital mixing valve connection port 1 and route as shown. Connect the coupler cable to the 9.8m cable and route to the user controller location

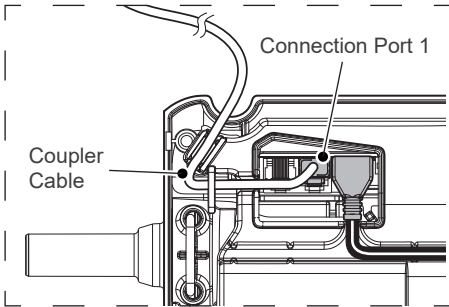

Top View

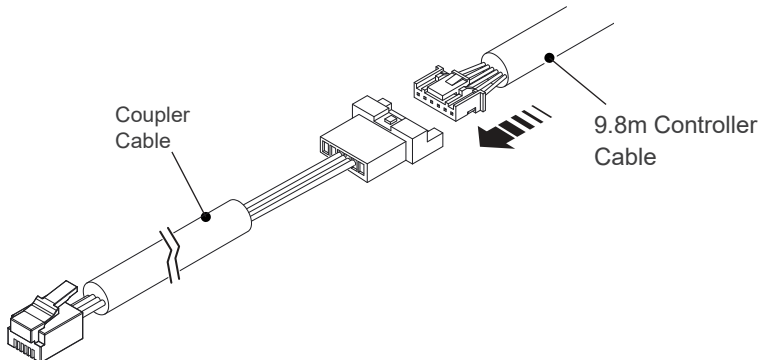
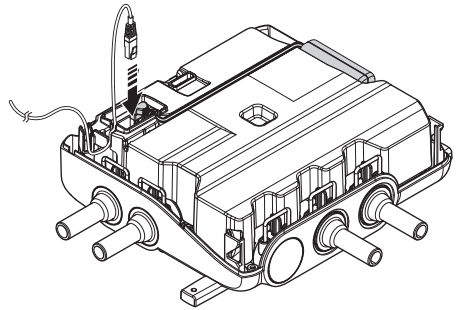

- 5** Fit the backplate to the wall in the orientation shown using the fixing screws (supplied). Tighten by hand, do not over tighten.

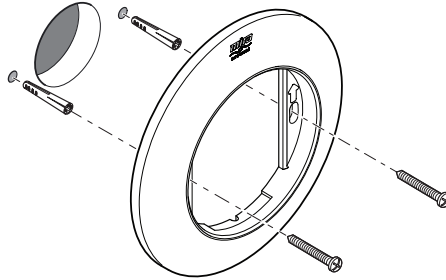

- 6** Connect the cable on the back of the controller to the cable that comes from the valve.

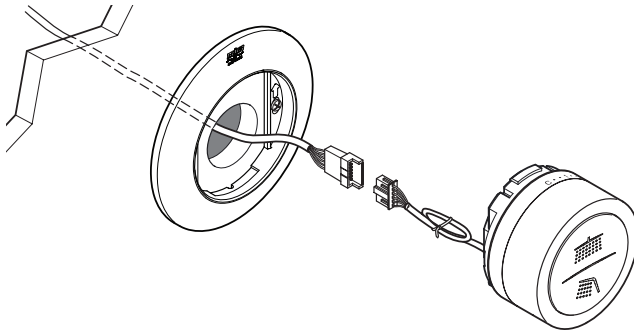

- 7** Locate the top of the controller in the backplate and press down on the bottom button as you install in position.

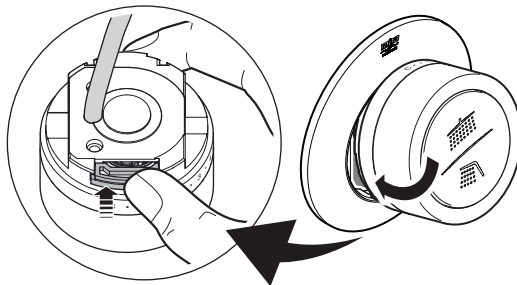

To remove the controller, place a 1.5mm Allen key (supplied) or small flat blade screwdriver into the hole on the bottom of the user interface, press upwards, pivot the controller up from the bottom and lift it off to remove it from the wall mount.

Commissioning (High Pressure Product)

WARNING! For the Pumped low pressure valve you must follow the separate valve commissioning sequence in the section below.

- 1** Ensure all items on the below checklist have been ticked off prior to commissioning.
- This is a high pressure system product, **DO NOT** install on a gravity fed low pressure system.
 - Ensure product is installed in a recommended orientation (as shown on 22).
 - Ensure supplies are correctly plumbed and are on.
-

- 2** Turn on the water supply. Ensure pipework is flushed and isolators are turned on.



- 3** Turn on the electrical supply to digital mixing valve.

The digital mixing valve will power and perform a self check where the LED will indicate a RED light initially and will then change to BLUE light after a few seconds.

Note: If the LED does not turn to a solid BLUE light after 10 seconds, indicating the product is ready to use, refer to the troubleshooting or fault diagnosis section.

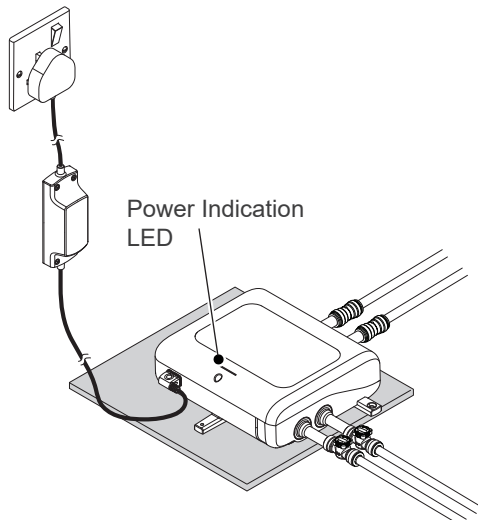

- 4** Make sure the end of the hose is in either the bath, shower tray or other water catchment area (not including bath fill only product).

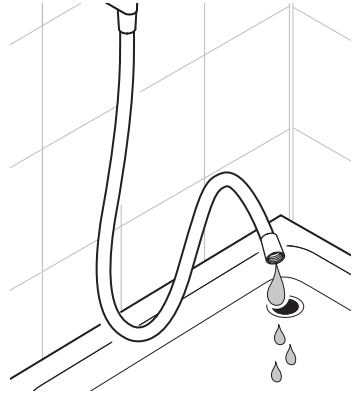

- 5** Press the button to turn the shower on and reduce temperature to full cold.

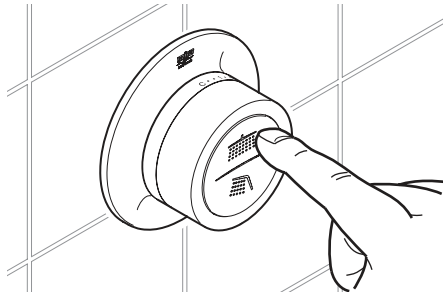

- 6** Run cold water through (approximately 2 minutes) and check entire installation for water leaks. Press the controller button to turn the shower off. Fit the second hose washer and handshower.

- 7** Press the controller button to turn shower on. Test operation of shower by increasing/ decreasing the temperature.

- 8** Flush the second outlet for 10 seconds (Overhead or Bath fill). Once complete, fit and secure the fittings as per instructions in the fittings section.

Commissioning (Pumped Product)

WARNING: Silent pump cannot be dry run for extended period.

1 Ensure all items on the below checklist have been ticked off prior to commissioning.

- This is a gravity system product, do not install on a mains pressure system.
- Ensure product is installed in a recommended orientation (as shown on 22).
- Ensure pipework is completely free of airlocks & dead legs.
- Ensure pipework is flushed.
- Ensure supplies are correctly plumbed, are on & tanks full.
- Ensure overhead and handset is removed, hose dropped & directed to waste.

Note: The remote on/off button will not operate until commissioning has been completed.

2 Turn on the water supply and open water inlet supply isolators.



3

Turn on the electrical supply to digital mixing valve.

The digital mixing valve will power and perform a self check where the LED will indicate a RED light initially and will then change to a BLUE/RED flashing light after a few seconds.

Note: If the LED does not turn to a BLUE/RED flashing light after 10 seconds, indicating the product is ready to commission, refer to the troubleshooting or fault diagnosis section.

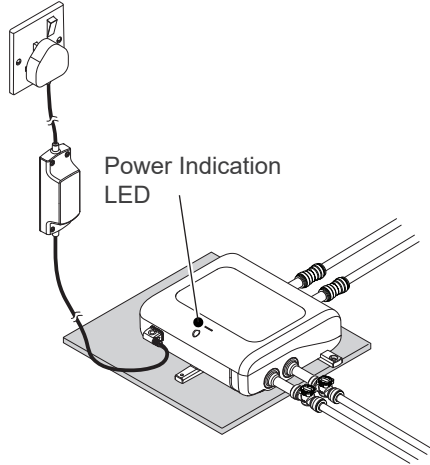

4

Commissioning Required.

The user controller will indicate commissioning is required with left (A) to right (B) flashing. Initiate commissioning by pressing the On/Off button (⏻) or top button on dual products. **DO NOT** leave the product unobserved during commissioning. If you need to abort the process, press again to 'Cancel', this can be done at any time during commissioning.

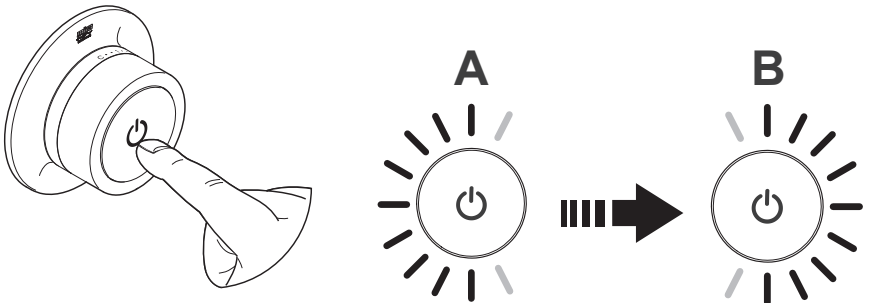

5 Indicate Flow.

Wait for water to flow from the end of the hose or bath filler, then step on by pressing and holding the flashing button for 3 seconds. The product may step itself on if your water pressure is sufficient.

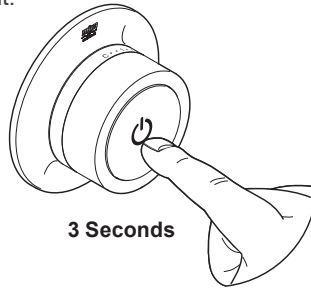

6 Pump Commissioning.

The product will then commission the pump, indicated by top (C) to bottom (D) flashing. Wait for this to be completed. A noisy pump is indicative of a lack of water – this may suggest supply issues. The product will indicate the process is complete by stopping flashing (E).

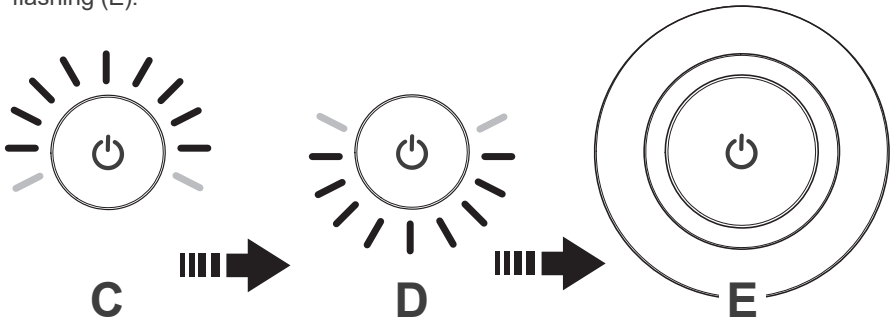

7 Failed Commissioning.

If commissioning has failed, the product will return to left (A) to right (B) flashing. Review the installation and retry.

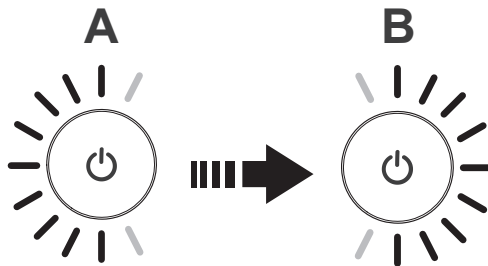

8 Flush the second outlet for 10 seconds (Overhead or Bath fill). Once complete, fit and secure the fittings as per instructions in the fittings section.

Using the Shower

Note: The factory default maximum temperature is set to 45°C.

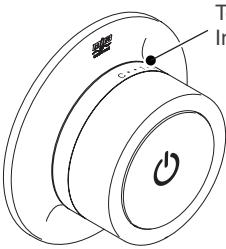

Temperature Indicator

On/Off Button

Turns product On/Off.
Rotary movement selects showering temperature

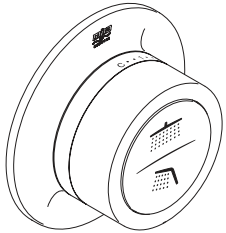
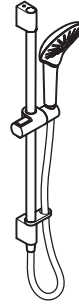

Shower Overhead

Symbol - (Top Button) –
Turns Product Overhead On/Off.

Shower Handset Symbol

(Bottom Button) – Turns Product Handset On/Off.
Rotary movement selects showering temperature

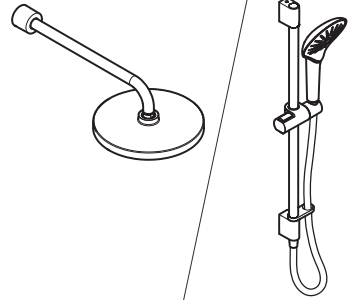

On/Off Symbol

(Top Button) – Turns Product Bath Fill On/Off.

Bath Symbol - (Bottom Button) – Turns Product Bath Fill Preset On/Off.

Rotary movement selects bathfill water temperature

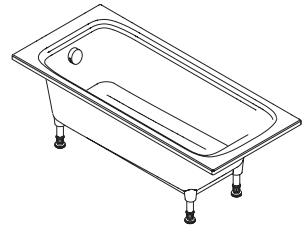

Shower Symbol - (Top Button) – Turns Product Shower On/Off.

Bath Symbol - (Bottom Button) – Turns Product Bath Fill Preset On/Off.

Rotary movement selects showering/bathfill water temperature

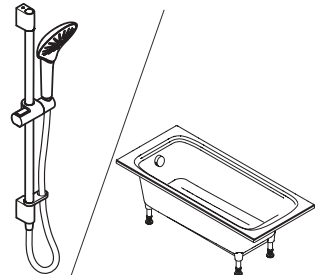

When you turn on the product and water begins to flow, the temperature indicator light will begin to flash to show the product is warming up. Once the preselected outlet temperature has been reached, the indicator light will stop flashing.

Set Up: Controller

Maximum Temperature Setting with the User Interface

Single Outlet Shower

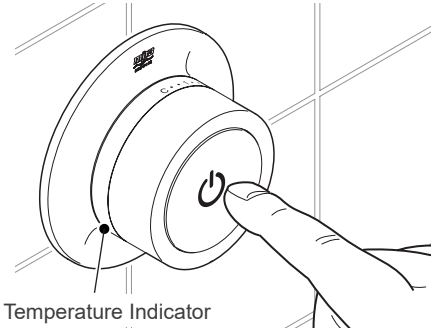

Hold down the On/Off Button for approximately 10 Seconds until the Temperature Indicator light pulses on/off.

Note: After 5 seconds the lights will pulse to indicate pairing mode, you need to continue to hold the button for the entire 10 seconds.

Adjust the temperature indicator in accordance to the table below to set the desired maximum temperature.

To remove the product from the connected app account, turn the dial to full cold 'C' position.

Temp Indicator Position	Temp °C
1 - 3	41
4 - 6	45
7 - 9	48
H	Exit No Change

Caution! Make sure that the maximum outlet temperature is suitable and safe for all users.

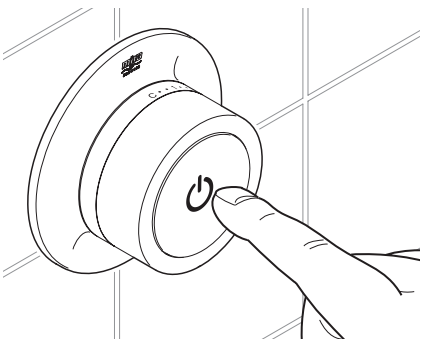
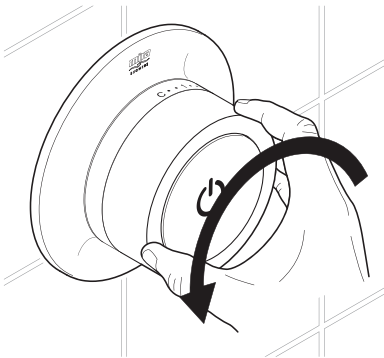

Press the On/Off Button to set the maximum temperature. The temperature indicator light will flash twice to confirm the setting has been completed.

Dual Outlet Shower / Bathfill / Shower Bathfill

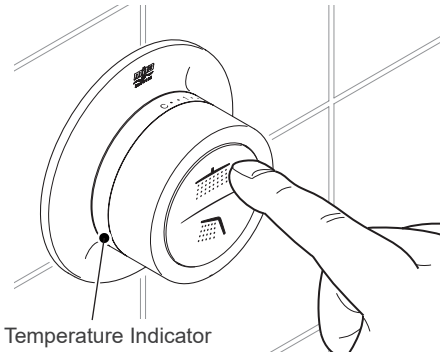

Hold down the Top button for approximately 10 Seconds until the Temperature Indicator light pulses on/off.

Note: After 5 seconds the lights will pulse to indicate pairing mode, you need to continue to hold the button for the entire 10 seconds.

Adjust the temperature indicator in accordance to the table below to set the desired maximum temperature.

To remove the product from the connected app account, turn the dial to full cold 'C' position.

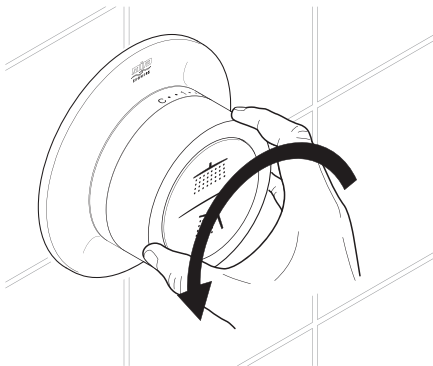

Temp Indicator Position	Temp °C
1 - 3	41
4 - 6	45
7 - 9	48
H	Exit No Change

Caution! Make sure that the maximum outlet temperature is suitable and safe for all users.

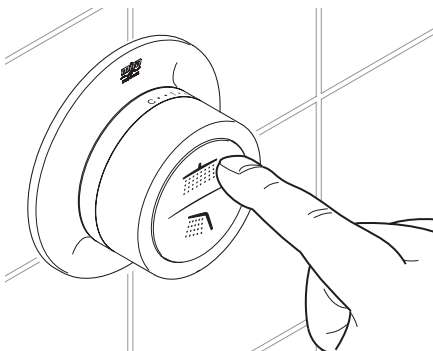

Press the top button to set the maximum temperature. The temperature indicator light will flash twice to confirm the setting has been completed.

Bathfill Preset Adjustment

For Products with a Bath Fill Shower Interface and Dual Shower/Bath fill Interface

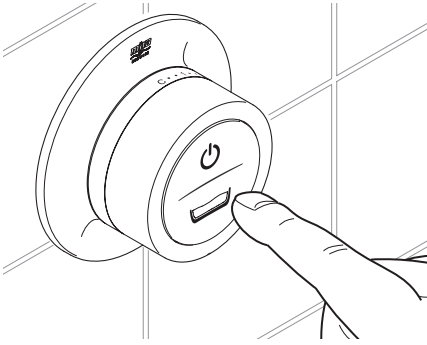

Bath Fill Preset – Push down the plug in the bath. Hold down the Bath Symbol Button (bottom half) for approximately 5 Seconds until the Bath Symbol Button flashes. Press the Bath Symbol Button (bottom half) to start the Bath filling. Rotate the Chrome Bezel to adjust the temperature indicator to set the temperature. On reaching the ideal fill level and desired temperature, press the Bath Symbol Button (bottom half) to stop the water & save the Bath Fill Preset.

Note: Factory Default Bath Fill Preset is 5 minutes duration at 42°C Inlet Temperature.

Bath Fill Preset temperature will calculate the average temperature over the Preset fill duration & take into account adjustments made to the User Interface rotary temperature dial during this time period.

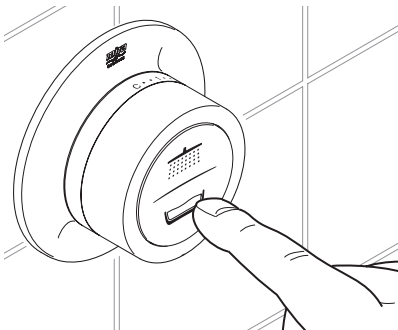

User Interface Function Guide

Condition / State	Interface On / Off Button State	Temperature Indicator Ring State
Motor homing after power cycle	Off	Ring Flashing 1x Per Second
Standby	Dim or Off	Off
On (not at temperature)	Relevant Button On	Pulsing
On (after reaching temperature)	Relevant Button On	On
Pairing Mode	Off	Rotating anti-clockwise
Ready to Set temperature	Dim or Off	Flashing 2x per second
Ready to Set Bath fill learn mode	Flashing 1x per second	Off
Whilst in Bath fill learn mode	Flashing 1x per second	On
Timeout warning at 1 min and 10s before end of run time	Flashing 6x per second	Pulsing or On
Over Temperature error	Flashing 2x per second	Flashing 2x per second
Missing Thermistor error	Flashing 2x per second	Off
Stuck button error	Flashing 2x per second	Off
Wrong interface error	Flashing 2x per second	Off
Comms error	Flashing 2x per second	Off
Other Valve error	Flashing 2x per second	Off
Both Valve and UI error	Flashing 2x per second	Off
Valve Frozen. DO NOT use and seek advise form you plumber.	Flashing 4x per second Alternately	Flashing 4x per second Alternately

Accessories

	Product	Product Code
	Mira Wireless Remote Accessory	2.1903.098

Set Up: Mobile App

You can set up and customise your shower using your Apple iPhone or Android Phone with the companion Mira Showers app.

- 1 Download the Mira Showers app from appropriate app store for your device.



Note: Not all Apple or Android devices are compatible - please refer to the relevant app store compatibility listing for more details and ensure your device's Operating System is up to date with the latest updates.

Mira endeavour to ensure that the Mira Showers app is compatible with the latest versions of Apple and Android Operating System. If your device is not capable of running the latest versions of Operating Systems the Mira Showers app may NOT be compatible with your device. Please ensure your mobile device is configured for automatic app updates to ensure that the Mira Showers app is kept up to date with the latest bug fixes and performance enhancements.

- 2 Once the Mira Showers app has been installed, open the app on your device and follow the on-screen instructions to connect your phone to your Digital Mixing Valve.

- 3 You can then use the Mira Showers app to customise and control your Digital Mixing Valve remotely.

Warning! Never remotely operate or alter any of the Mira Activate shower settings if it is already occupied and / or being used by another person or if you are not in the vicinity of the outlet. This could result in flooding of the shower cubical or scalding of the user.

Fault Diagnosis

Read the section “Important Safety Information” first. As with most electronic equipment resetting the digital mixing valve by powering it down waiting a few seconds then powering it up again can often cure most issues.

Providing the Digital Mixer Valve has been correctly installed and is operated in accordance with the instructions contained in this guide, difficulties should not arise. If any maintenance is required, then it must be carried out by a competent tradesperson. Before replacing any parts make sure that the underlying cause of the malfunction has been resolved.

Warning! There are no user serviceable components beneath the cover of the appliance. Only a competent tradesperson should remove the cover.

The digital mixing valve has built-in sensors to help diagnose system and product issues. To access these advanced diagnostics features, please download the Mira Showers app (see section “Set Up: Mobile App”).

Please follow this self-diagnosis section to be sure the product is at fault before contacting Mira.

Diagnosis stage 1 (Error code check):

In the first instance, check your product is not displaying any ‘Symptoms’, such as flashing lights, listed in the table below. You can also check for error codes on the Mira Showers app.

Only limited fault diagnostics can be carried out with the interface only. To display error codes and access full diagnosis functionality, you will need to download the Mira Showers app.

If you have an error code not listed below, or if the errors continue to occur after it has been reset, please contact Mira customer services team to resolve the issue.

If you do not have an error code or symptom listed below, proceed to Diagnosis stage 2.

Symptoms	Error Code	Description and Remedial Action
Temperature Indicator Ring and Interface On / Off Button flashing alternately (4 times a second)”	11 or 111	<p>DO NOT ATTEMPT TO OPERATE YOUR PRODUCT. A temperature of less than 0°C has been detected in your product which could have caused internal damage leading to potential leaks.</p> <p>It is essential that your product is protected from freezing conditions otherwise serious damage can occur.</p> <p>Warning! If the valve module has been subjected to freezing conditions it may require inspection to ensure internal damage has not occurred, (contact your installer). If no sign of leaks, reset the product by powering off for 30 seconds or re-setting in the Mira Showers app. Ensure there are no leaks when the shower is first used.</p>

Symptoms	Error Code	Description and Remedial Action
No Lights on interface	N/A	If shower is not powered on or fully functional, skip to diagnosis section 2.
	N/A	If product is still functional: Backlight may be turned off in app. Refer to settings in the Mira Showers app.
Interface On / Off Button Flashing (2 times a second)	N/A	Wrong interface connected. Check the app “ Technical Information ” Screen. Text will be black if correct, red if wrong. Contact Mira customer services team.
	N/A	User Interface has lost communications with the valve. Check the connection cable is intact and plugged into the valve securely. Power off the product for 30 seconds or reset the product in the Mira Showers app. If the error re-appears, please contact Mira customer services team.
	4	Outlet thermistor not detected - Contact Mira customer services team.
	N/A	User Interface stuck button detected. Check user interface button operation then power off the product for 30 seconds or reset the product in the Mira Showers app. If the error re-appears, please contact Mira customer services team.
	37	Hot water temperature spike detected - Turn off the product to maintain safety. Check incoming water temperature is within specification and restart product. Refer to diagnosis section 4d.
	40	A software error has been detected. Try powering off the product for 30 seconds or resetting in the Mira Showers app.
	45	An outlet solenoid error has been detected. Try powering off the product for 30 seconds or resetting in the Mira Showers app.
	50	No (or very low) flow has been detected by the product. This may be indicated by a low or no flow from the product. Refer to diagnosis section 4b.
	54	Unusually high flow has been detected. Try powering off the product for 30 seconds or resetting in the Mira Showers app.
	112	Hot inlet temperature is above 85°C. Reduce temperature of combi boiler or tank thermostat.
Temperature Indicator Ring and Interface On / Off Button flashing (2 times a second)	3 or 7	Outlet, temperature too hot. Try powering off the product for 30 seconds or resetting in the Mira Showers app. Refer to diagnosis section 4d.
Flow stops during showering	9	Warning! Probable system issues. Check system pressures and temperatures are within specification and hot water inlet temperature is not too high. Refer to diagnosis section 4d for further steps.
	N/A	See section 4e.

Symptoms	Error Code	Description and Remedial Action
Unable to download the Mira Showers Mobile App	N/A	Phone OS out of date. Update mobile phone to the latest operating system. Note: The Mira Mode showering app will only run on the latest Apple and Android Operating Systems.
Repeated Mira Mode Showering App Failures	N/A	App may be corrupted. Delete the Mira Showers app, reboot the mobile phone and re-install the Mira Mode showering app.
Loss of control via the User Interface or On/Off Remote Button. Shower turning On/Off	N/A	Another user is controlling the shower remotely with the mobile phone app. Ensure no one else uses the mobile phone app whilst you are showering.

Diagnosis stage 2 (Valve status check):

If you do not have an error code, or if the controller is not functional you should then check the status indicator light on the product.

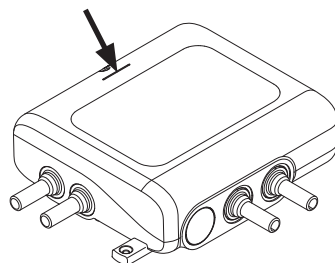

Power Indicator Status	Description
Blue	Product should be functional. If your product is still exhibiting problems continue to Diagnosis stage 4 .
Red	Product has an error. Follow Diagnosis stage 1 or continue to Diagnosis stage 4 .
Flashing Red/Blue	(Pumped Product Only) Product is in priming sequence. Follow the commissioning sequence in “Commissioning Section”.
Off	Product is not receiving power. See Diagnosis stage 3 .

Diagnosis stage 3 (No Power to the product):

1. Check the product is plugged in and switched on.
2. Check the power connector from the power supply is securely connected into the back of the digital mixing valve.
3. Check the circuit breaker or RCD in your consumer unit has not tripped.
4. Check the fuse and replace if necessary (3 Amp).
5. Contact Mira Customer Service Team if none of the above restored power to the digital mixing valve.

Diagnosis stage 4 (Product powered, but no error code):

If you have a problem with your shower but do not have an error code, find the relevant section and follow the recommendations before contacting Mira.

4a - Controller not powered:

1. Check the digital mixing valve is functional (Diagnosis stage 2).
2. Turn off the valve for 30 seconds and re-power. This will restart the controller.
3. Check the controller's extension lead is plugged into the valve and that the cable is not damaged.
4. Remove the controller and check the connector to the extension lead is fully inserted and not damaged or wet.
5. Contact Mira Customer Service Team if none of the above resolved the issue.

4b - No Flow / Low Flow:

Low flow through the product normally indicates a restriction in the system, or incorrect system pressures.

1. Check there are no digital mixing valve errors (**Diagnosis stage 1**).
2. Check the maximum flow has not been set too low in the mobile app.
3. Check the inlet isolators to the digital mixing valve are fully open.
4. For mains-fed (High Pressure / Combi) products, check that the incoming supply to the property is not too restrictive. Fully open the stop cock and check that the 'Pressure Reducing Valve' (if fitted) is not set too low. Refer to the 'Minimum maintained pressure' requirement for your product.
5. Check and clean the inlet filters (refer to "Cleaning and Maintenance Section").
6. Check for restrictions in the shower head / hose and clean or replace if necessary.
7. Use the Mira Showers app to check your hot water temperature is within specification.
8. Contact Mira Customer Service Team if none of the above resolved the issue.

4c - Product flowing water when switched off:

The digital mixing valve reduces the water flow slowly before final shut-off to reduce the severity of water hammer. The time duration depends on the flow rate and system pressures. This is normal and not a product fault.

Shower fittings can continue to drain down after the digital mixing valve is shut off, especially where there are large volumes of water present (e.g. large deluge heads or long pipe runs). This process can take several hours and may be triggered by changes in temperature or atmospheric pressure. This is normal and not a product fault. We would therefore recommend that all water outlets are kept contained within the water catchment area.

1. Check the issue is not a natural draining of the fittings. Remove the fittings and monitor the outlet if necessary.
2. Activate the shower a number of times at maximum flow to dislodge any debris.
3. If none of the above resolved the issue, isolate the water and power supply and contact Mira Customer Service Team.

4d - Showering temperature is hotter / colder than indicated or is fluctuating:

Note: The temperature displayed on the user interface is measured inside the digital mixing valve, not at the shower outlet.

The perceived temperature of the water from your shower can vary with shower fittings and room temperature. A wider, finer spray will cool more quickly and feel cooler than a direct spray, and long outlet pipe runs can also influence the blend temperature, in which case you may need to adjust the showering temperature.

1. **Combi Boiler fed products:** Check the hot water supply is hot enough when the shower is in use. Combi boilers are sometimes unable to maintain temperatures at higher flows or may cut-out at lower flows. Check no other devices are using hot water at the same time. Reduce or increase the maximum flow rate to around 8 litres per minute using the Mira showers app and see if that solves the issue. Tip: Use the Mira Showers app to check the temperature of the hot water inlet when the shower is running.
2. **Hot water storage tank fed products:** Check the hot water supply is not being depleted in use. Reduce the maximum flow rate using the Mira showers app or reduce showering time and see if that solves the issue. Tip: Use the Mira Showers app to check the temperature of the hot water inlet when the shower is running.
3. Check the hot and cold supplies are connected to the correct inlets, and that the temperature and pressures are within the product specification and are stable. Inlet water pressures must be nominally equal. **Note: Use the Mira Showers app to check the temperature of the hot water inlet is within the temperature range of 55°C - 65°.**
4. Check no other devices are using water at the same time. Devices switching on/off (e.g. washing machines, taps etc.) can rapidly change the water pressure of the system causing rapid pressure and temperature changes.
5. Ensure Inlet filters and check valves, shower head and hose are not blocked (refer to "Cleaning and Maintenance Section").
6. If none of the above resolved the issue, and the measured temperature is significantly different to that on the controller display, contact Mira Customer Service Team.

4e - Shower or Bath Fill turning off too soon:

1. Check to see if you have 'Warm Up' mode enabled. This is designed to 'pause' the shower once showering temperature is reached.
2. Check to see if you have a maximum showering duration set. This is designed to turn off the shower after a pre-determined duration.
3. Check to see if you are using pre-defined bath fill preset. These may turn off the bath fill after a pre-determined duration.
4. The shower is designed to turn off after 30 minutes.
5. Use the Mira Showers app to check the error log. The shower is designed to turn off if the outlet temperature is too high.
6. Check inlet water temperature and pressures are within specification. The shower may turn off if these are out of specification. Tip: Use the Mira Showers app to check the temperature of the hot water inlet.
7. If none of the above resolved the issue, contact Mira Customer Service Team.

4f - Noise:

1. Pumped digital mixing valves can get air locked if not installed in accordance with the instructions in this guide and may exhibit outlet flow fluctuations and a high pitch "squealing" noise. Ensure the plumbing system eliminates air locking.
2. Some plumbing systems can produce "water hammer". To reduce this effect, ensure all pipework is securely fixed.
3. The type of wall or flooring the appliance is fixed to will affect the perceived noise level from the product. For a quieter operation install the product to solid walls or structures.
4. If none of the above resolved the issue, contact Mira Customer Service Team.

Cleaning and Maintenance

Cleaning

Many household and commercial cleaners, including hand and surface cleaning wipes contain abrasives and chemical substances that can damage plastics, plating and printing and should not be used. These finishes should be cleaned with a mild washing up detergent or soap solution, and then wiped dry using a soft cloth.

Important! Keeping the showerhead clean and free from limescale will ensure that your shower and showerhead continue to perform to their maximum. A blocked showerhead can restrict the flow rate and may cause damage to your shower. Use your thumb or a soft cloth to wipe any limescale from the nozzles.

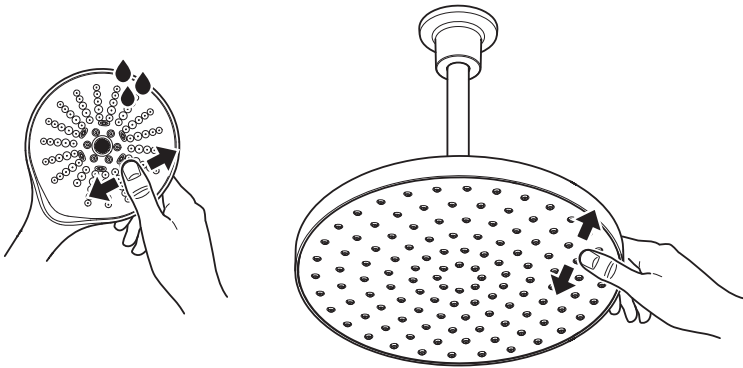

Inspecting the hose

Important! The shower hose should be inspected periodically for damage or internal collapse. Internal collapse can restrict the flow rate from the showerhead and may cause damage to the shower. Remove the shower hose from the shower, inspect and replace the hose if necessary.



Unscrew the hose from the showerhead and the shower outlet.

Inspect the hose.

Cleaning the CloudCore™ spray plate (Mira Maxim ONLY)

- 1 Insert the spray plate removal tool into the corresponding feature in the core sprayplate.

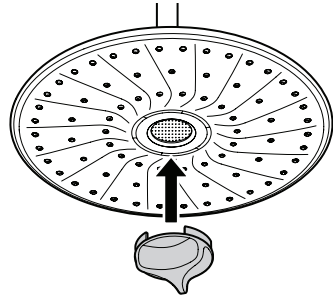

- 2 Hold the deluge showerhead with one hand and turn the removal tool anticlockwise to unscrew the core sprayplate from the showerhead.

Note: There may be some residual water in core spray plate.

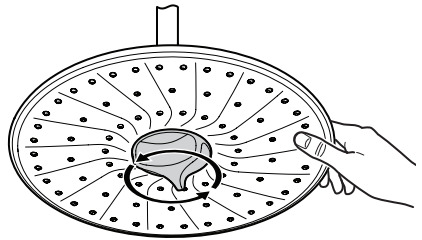

- 3 Clean the core spray plate silver mesh with mild washing up detergent or soap solution, rinse under water and wipe using a soft cloth or brush.

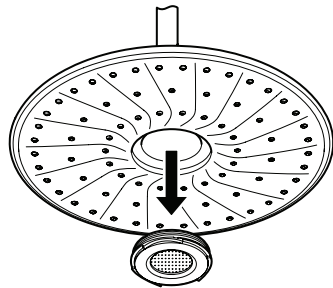
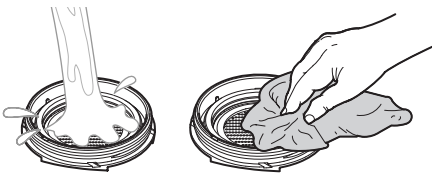

- 4 Replace with alternative or cleaned CloudCore™ or RainCore™ spray plate. Insert the spray plate tool into the corresponding feature and turn clockwise to tighten.

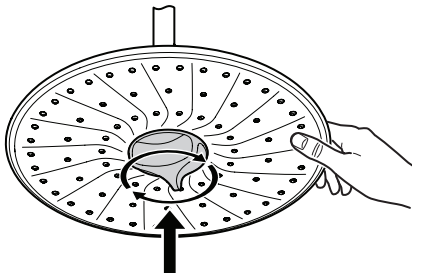

Replace/Clean the Check Valves/Filters

Read the section “Important Safety Information” first.

Before replacing any parts, ensure that the underlying cause of the malfunction has been identified. If the digital mixing valve is dismantled during installation or servicing then upon completion the product must be inspected to ensure there are no leaks.

Warning! There are no user serviceable components beneath the cover of the appliance. Only a competent tradesperson should remove the cover.

Check valve Cartridges and Filters - Removal and Installation

Hot water entering the cold supply, or vice versa, indicates that immediate attention is necessary. This is carried out by removing and cleaning, or renewing as necessary, the check valve cartridges.

Caution! Running your product without inlet filters can cause valve damage and will invalidate your product guarantee.

Isolate the water supplies and turn on an outlet for 5 seconds to release pressure within the valve. Isolate the electrical supply.

Loosen the screw and remove the cover from the digital mixing valve.

Carefully remove the clip and pull out the filter housing.

Remove the filter and rinse in clean warm water removing any dirt or debris. Replace if the filter mesh is damaged.

If the check valves needs to be replaced, carefully remove them from inside the product and replace with new parts.

Refit the filter housing into digital mixing valve. Insert the clip to secure the filter housing.

Refit the supply pipes and restore water supply and electrical supply. Test shower and check for leaks.

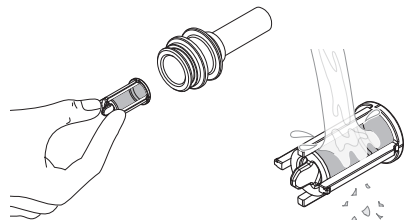
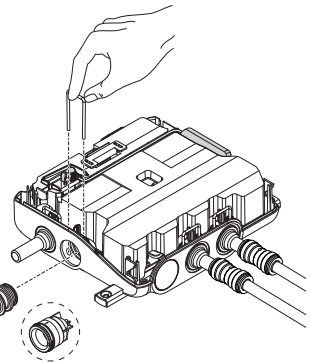
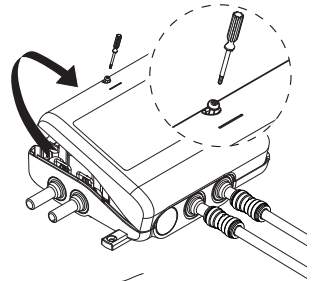

Disposal and Recycling

When this appliance has reached the end of its serviceable life it should be disposed of in a safe manner, in accordance with current local authority recycling or waste disposal policy. For more information about recycling, please contact your local council office.

Decommissioning and Recycling for WEEE



Electrical and electronic devices contain a range of materials that can be separated for recycling and used in new products. This product should not be disposed of with your general household waste. When this product has reached the end of its serviceable life, please take it to a recognised WEEE (Waste Electrical and Electronic Equipment) collection facility such as your local civic amenity site for recycling. Your local authority or retailer will be able to advise you of your nearest recycling facility.

For more information, visit <http://repic.co.uk/consumers/>

Frequency Bands and Maximum Radio Frequency Power

Hereby, Kohler Mira Ltd. declares that the radio equipment type Mira Mode is in compliance with EU Directive 2014/53/EU & UK S.I. 2017/1206. The full text of the EU & UKCA declaration of conformity is available at the following internet address:
www.mirashowers.co.uk

Technology	Frequency Band	Maximum Power
Bluetooth® Low Energy	2402-2480MHz	< +4dBm

The Product Security and Telecommunications Infrastructure (Security Requirements for Relevant Connectable Products) Regulations 2023

Hereby, Kohler Mira Ltd. declares that this radio equipment is in compliance with The Product Security and Telecommunications Infrastructure (Security Requirements for Relevant Connectable Products) Regulations 2023 (S.I. 2023/1007). The full Statement of Compliance and Vulnerability Disclosure Policy is available at the following internet address:
www.mirashowers.co.uk

Customer Service

Guarantee

Your product has the benefit of our manufacturer's guarantee which starts from the date of purchase. This guarantee only applies in the United Kingdom and Republic of Ireland.

Activating Your Guarantee

Registering your guarantee is quick and simple. To ensure your product is covered, please register online.



Scan the QR code to activate your guarantee now or call 0800 5978551 within 30 days of purchase (UK only).

What is Covered:

- The guarantee applies solely to the original installation under normal use.
- The product must be installed and maintained in accordance with the instructions given in this guide.
- Servicing must only be undertaken by us or our appointed representative.
- Repair under this guarantee does not extend the original expiry date. The guarantee on any replacement parts or product ends at the original expiry date.
- For shower fittings or consumable items we reserve the right to supply replacement parts only.

The guarantee does not cover:

- Call out charges for non product faults (such as damage or performance issues arising from incorrect installation, improper use, inappropriate cleaning, lack of maintenance, build up of limescale, frost damage, chemical attack, corrosion, system debris or blocked filters) or where no fault has been found with the product.
- Water or electrical supply, waste and isolation issues.
- Routine maintenance or replacement parts to comply with the requirements of Building / Plumbing / Electrical Standards or Schemes.
- Compensation for loss of use of the product or consequential or indirect loss of any kind.
- Damage or defects caused if the product is repaired or modified by persons not authorised by us or our appointed representative.
- Accidental or wilful damage.
- Products purchased ex-showroom display.
- Disinfection or descaling to reduce bacterial growth or contamination.

What to do if something goes wrong

If your product is not working correctly please refer to this manual or the Mira website for fault diagnosis and to check that it is installed and commissioned in accordance with our instructions. If this does not resolve the issue, our Customer Services team are here to help get you back up and running. To help us solve your problem quickly, please have your product name, power rating (if applicable) and date of purchase to hand.

Visit www.mirashowers.co.uk

Visit our website to register your guarantee, book a service visit, diagnose faults and purchase products.

Spares and Accessories

We stock a full range of spare parts and fittings and are all available to purchase either online or over the phone. Our online spare parts selector tool will help you quickly and easily identify the spare part for your product.

Visit www.mirashowers.co.uk/parts-and-accessories

Replacements and Repairs

In the unlikely event that your product needs a repair, our nationwide repairs and installation team are here to help. You can book a convenient date and time online.



Scan the QR code to book a service visit now or visit www.mirashowers.co.uk/support/repair-services/repair-service

We also offer a comprehensive replacement service for when your product needs a little refresh, visit our website or contact our team for more information on our replacement services.

Help us improve

Your experience is important to us and your review (whether good, bad or otherwise) will be posted on Trustpilot.com immediately to help other people make more informed decisions.

Visit uk.trustpilot.com/review/www.mirashowers.co.uk

Need to get in touch?

UK

T: 0800 001 4040
E: askus@mirashowers.com
www.mirashowers.co.uk

Eire

T: 01 531 9337
E: customerserviceeire@mirashowers.com

Mira is a registered trade mark of Kohler Mira Limited.

The company reserves the right to alter product specifications without notice.

Registered Office:
Cromwell Road,
Cheltenham,
Gloucestershire
GL52 5EP

EU Importer address:
Kohler France S.A.S.
30 Boulevard de la Bastille,
75012 Paris,
France



mira
SHOWERS