

Mira Platinum

Digital Shower

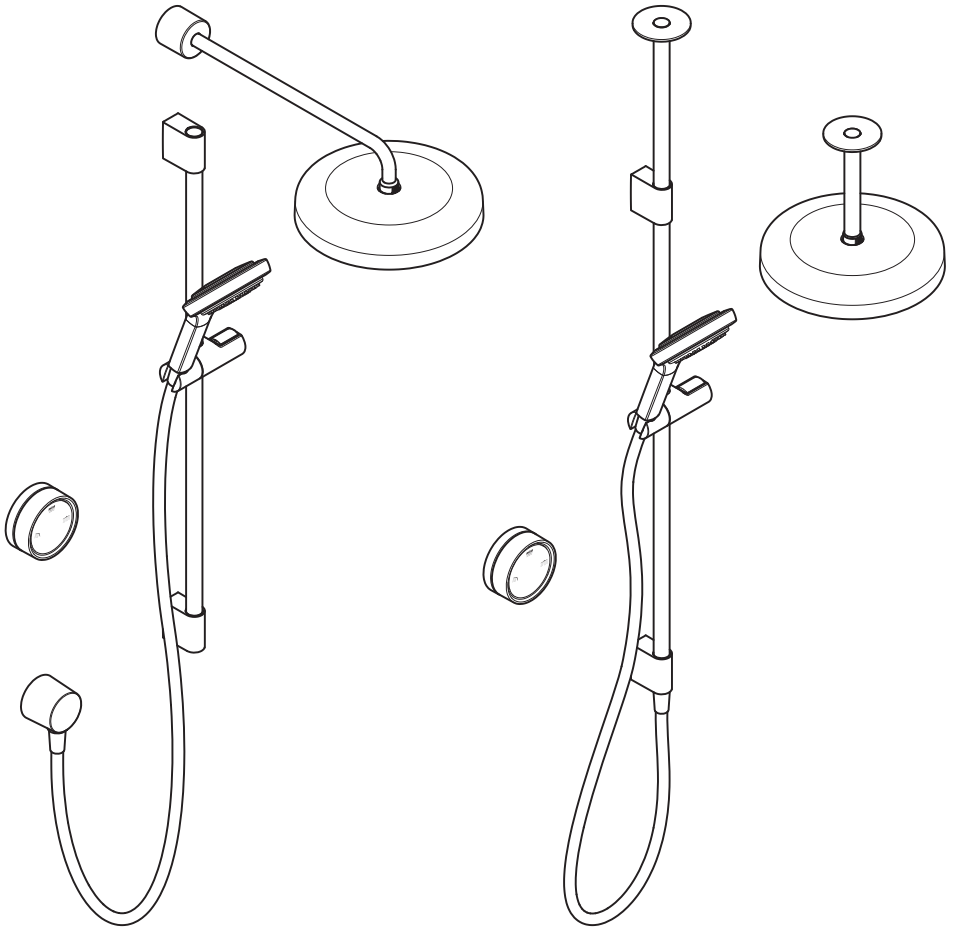

1514415-W2-C

Installation and User Guide

Please leave these instructions with the user

mira
SHOWERS

Thank you for purchasing a Mira Platinum. You must read this guide thoroughly, and having done so, keep it handy for future reference. For step-by-step installation videos, datasheets or spares information, please visit the Mira Showers website.

Contents

Important Safety Information	3
Pack Contents	7
Guarantee	12
Recommended Usage	12
Products Covered	12
Patents and Design Registration	12
Specifications	13
Suitable Plumbing Installations	16
Showering Maximum Flow Rate	18
Installation Schematic	19
General Installation	20
Installation	
Digital Mixing Valve	21
Ceiling Fed Shower Fittings	29
Rear Fed Shower Fittings	33
Deluge Overhead	38
User Controller	43
Commissioning	45
Using the Controller	49
User Controller: Features	52
Set Up: Mobile App	56
Set Up: Wi-Fi Connection	58
Fault Diagnosis	59
Accessories	64
Cleaning & Maintenance	65
Customer Service	68

Important Safety Information

Products manufactured by Kohler Mira Ltd. are designed to be safe, provided that they are installed, used and maintained in good working order, in accordance with our instructions and recommendations. Follow all warnings, cautions and instructions contained in this guide, and on, or inside the product. Failure to follow the instructions provided with this product will invalidate the guarantee.

Warning! To reduce the risk of fire, electric shock or injury please read the important information listed below.

Warning! This appliance contains magnets. Users fitted with a heart pacemaker or ICD should follow their normal safety precautions for products that contain magnets. The magnets are located in the User Controller and Cradle. There are no magnets in the showerhead.



1. Installation of this product must be carried out in accordance with these instructions by qualified, competent personnel. Read all instructions before commencing installation.
2. The electrical installation must comply with BS 7671 (commonly referred to as the IET Wiring Regulations) and all relevant building regulations, or any particular regulation or practice specified by the local electricity supply company.
3. The plumbing installation must comply with all national or local water regulations and all relevant building regulations, or any particular regulation or practice specified by the local water supply company.
4. Isolate the electrical and water supplies before commencing installation.
5. For any copper pipework ensure supplementary bonding is provided in accordance with the wiring regulations.
6. A 30mA Residual Current Device (RCD) must be included in the electrical circuit. This may be part of the consumer unit or a separate unit.

7. **DO NOT** install the digital mixing valve or user controller in areas with high humidity and temperature (e.g. steam rooms and saunas).
8. **DO NOT** install the digital mixing valve or fittings where they may be exposed to freezing conditions. Ensure that any pipework that could become frozen is properly insulated. Refer to 'General Installation' section for more information.
9. **DO NOT** perform any unspecified modifications, drill or cut holes in the product other than instructed by this guide. When servicing only use genuine Kohler Mira replacement parts.
10. If the product is dismantled during installation or servicing then, upon completion, an inspection must be made to ensure all electrical connections are secure and that there are no leaks.
11. **DO NOT** operate the product if water is leaking from inside the valve module. Isolate electrical and water supplies to the product and refer to the fault diagnosis section.
12. **DO NOT** allow the digital mixing valve to freeze. Isolate and drain down the valve if the property is being left for a period of time during winter. You may need to contact a plumbing professional to carry out this procedure.
13. **DO NOT** operate the product if the digital mixing valve has been exposed to freezing conditions. Internal damage may have occurred, which may result in a leak once the product has thawed. Isolate the power and water to the digital mixing valve and slowly allow to thaw (e.g. open the loft hatch to warm the loft space). Slowly un-isolate the water supply, and if no sign of leaks, re-power the digital mixing valve and check for normal operation. It is recommended to monitor the digital mixing valve periodically and check for leaks. If you are concerned or unsure, please contact a plumbing professional.
14. Make sure that you fully understand how to operate this shower and make sure that it is properly maintained in accordance with the instructions given in this manual.

15. Children younger than 3 years should not use this shower. Children 3 years to under 8 years should only use this shower under continuous supervision. Children aged 8 years and above and persons with reduced physical, sensory or mental capabilities or lack of experience or knowledge can use the shower if they are given supervision or instruction concerning use of the appliance in a safe way and understand the hazards involved.
16. **DO NOT** allow children to play with the product.
17. **DO NOT** allow children to clean or perform any user maintenance without supervision.
18. The water temperature needs to be set at a suitable temperature (body temperature is approximately 38°C). Babies and Children are more sensitive to temperature than adults and it is recommended to check the delivered water temperature is less than 37°C. In premises covered by the Care Standards Act 2000, the maximum mixed water outlet temperature must be set to 43°C.
19. The maximum mixed water temperature from the product is 46°C to take into account losses in metal baths. It is not a safe bathing or showering temperature.
20. Always check the water temperature is safe before bathing or showering.
21. **DO NOT** remotely operate or alter any of this product's shower and bathing settings if it is already occupied and / or being used by another person.
22. **DO NOT** use excessive force when making connections.
23. Avoid layouts where the shower hose will be sharply kinked. This may reduce the life of the hose.
24. The position of the shower fittings must provide a minimum air gap of 25mm between the handshower and the spill over level of any bath, shower tray or basin. There must be a minimum distance of 30mm between the handshower and the spill over level of any toilet, bidet or other appliance with a Fluid Category 5 backflow risk.

25. **DO NOT** operate the valve at voltages other than that stated on the rating label.
26. This appliance is only to be used and supplied at SELV (Safety Extra Low Voltage) using only the supplied detachable power supply unit.
27. The supply cord of the power supply unit cannot be replaced. If the cord is damaged the power supply must be replaced.
28. In the event of a cold water failure, the product is designed to reduce the flow. Depending on the temperature of the hot water, the valve may shut down to prevent scalding.
29. **Warning! Never remotely operate or alter any of the Mira Platinum shower settings if it is already occupied/being used by another person or you are not within the vicinity of the outlet. This could result in flooding of the shower cubical or scalding of the user.**
30. Always disconnect the appliance from the supply before assembling, disassembling or cleaning.

Pack Contents

Digital Mixing Valve High Pressure/Combi

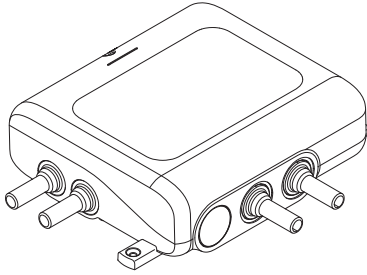

Digital Mixing Valve



2 x Push-Fit Isolators
(15mm Pipework Only)



1 or 2 x Outlet Connector
(Depending on number of outlets)



3 x Fixing Screws

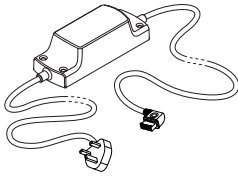

1 x Power Supply



3 x Wall Plugs



2 x Pozi Screws
(3.5 x 12mm)



2 x Fixing Feet

Digital Mixing Valve Pumped/Gravity

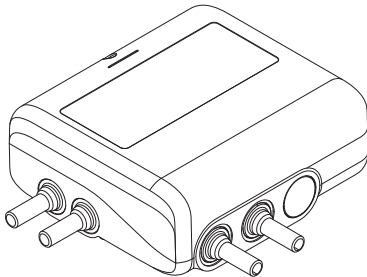

Digital Mixing Valve



2 x Push-Fit Isolators
(15mm Pipework Only)



1 - 2 x Outlet Connector
(Depending on number of outlets)



3 x Fixing Screws

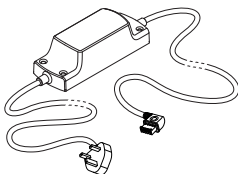

1 x Power Supply



3 x Wall Plugs



2 x Pozi Screws
(3.5 x 12mm)



2 x Fixing Feet

Ceiling Fed Shower Fitting

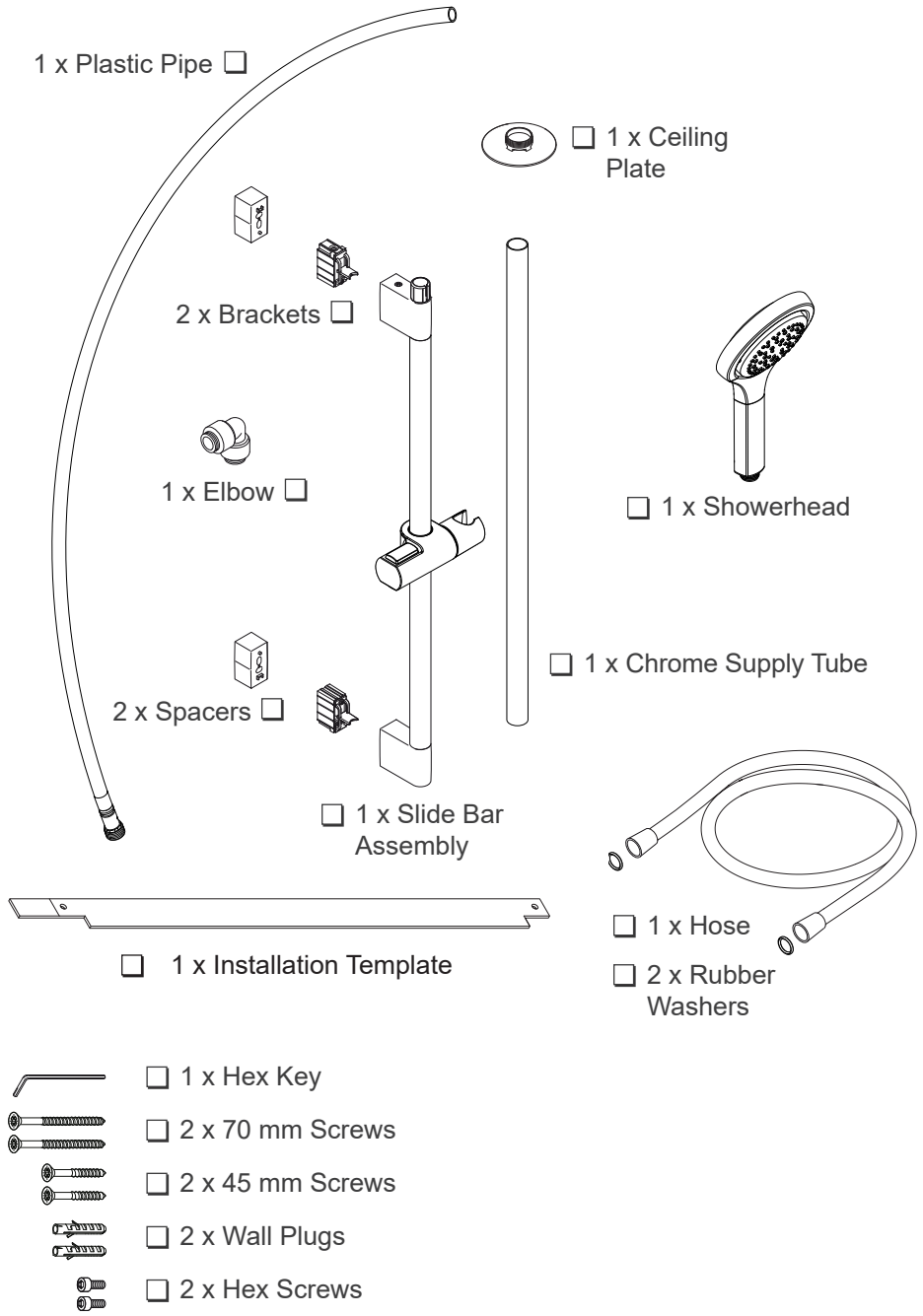

Rear Fed Shower Fitting

- 2 x Brackets
- 2 x End Plugs

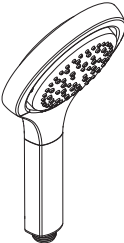

- 1 x Showerhead

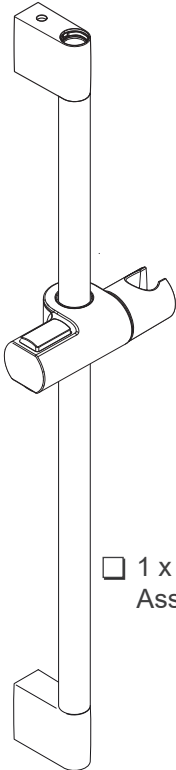

- 1 x Slide Bar Assembly

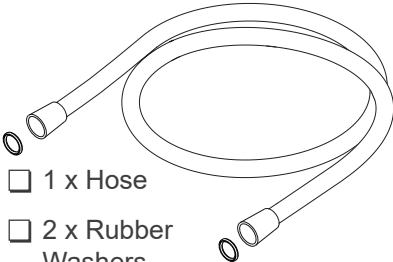

- 1 x Hose
- 2 x Rubber Washers

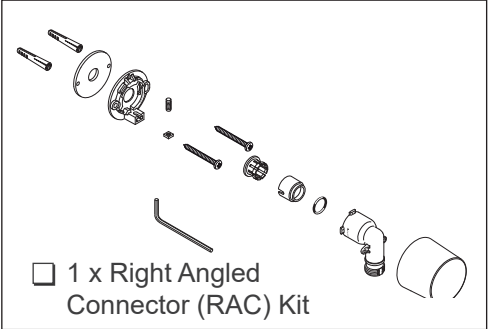

- 1 x Right Angled Connector (RAC) Kit

- 1 x Hex Key
- 2 x 45 mm Screws
- 2 x Wall Plugs
- 2 x Hex Screws



- 1 x Installation Template

Ceiling Overhead Fitting Kit (Dual Outlet models only)

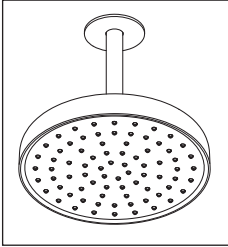

2 x Wall Plugs



2 x Hex Screws



1 x Nut



1 x Olive



1 x Ceiling Mount Plate



1 x Ceiling Plate

1 x Chrome Supply Tube



1 x Brazed Pipe

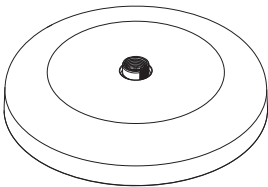

1 x Signature Overhead

Rear Fed Overhead Fitting Kit (Dual Outlet models only)

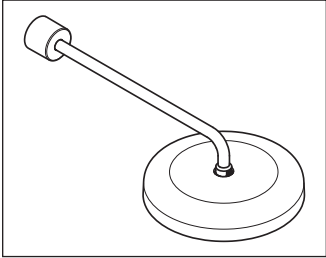

1 x Concealing Shroud



1 x Shower Arm

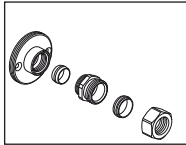
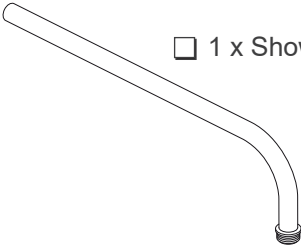

1 x Backplate Assembly

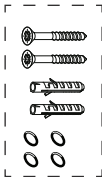

1 x Fittings Pack

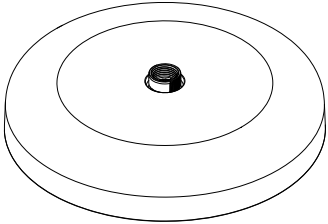

1 x Signature Overhead

User Controller

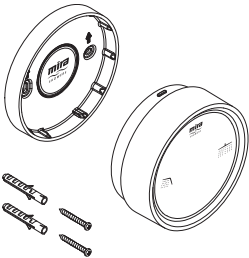

1 x User Controller

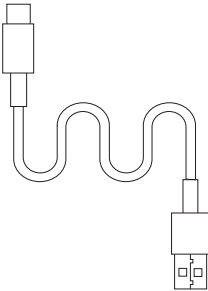

1 x Charging Cable

Guarantee

The Mira Platinum has been designed for domestic use only, it is not recommended for Commercial or Healthcare use. For domestic installations, Kohler Mira Ltd. guarantee the Mira Platinum against any defect in materials or workmanship for a period of five years from the date of purchase (shower fittings for one year).

For non-domestic installations, Kohler Mira Ltd. guarantee the Mira Platinum against any defect in materials or workmanship for a period of one year from the date of purchase.

Your guarantee is only valid if you follow the guidance within this installation and user guide, including the ‘Cleaning and Maintenance’ and ‘General Installation’ section. See the back page of this guide for more information.

Recommended Usage

Domestic	✓	Light Commercial	✗
Heavy Commercial	✗	Healthcare	✗

Products Covered

Product Name	Product No.	Product Code	Type 2 Designation
Mira Platinum Rear Fed (High Pressure)	1.1981.001	N90APr	HP-S
Mira Platinum Dual Rear Fed (High Pressure)	1.1981.002	N90BPr	HP-S
Mira Platinum Rear Fed (Low Pressure)	1.1981.004	N90FPr	LP-S
Mira Platinum Dual Rear Fed (Low Pressure)	1.1981.005	N90GPr	LP-S
Mira Platinum Ceiling Fed (High Pressure)	1.1981.007	N90APc	HP-S
Mira Platinum Dual Ceiling Fed (High Pressure)	1.1981.008	N90BPc	HP-S
Mira Platinum Ceiling Fed (Low Pressure)	1.1981.010	N90FPc	LP-S
Mira Platinum Dual Ceiling Fed (Low Pressure)	1.1981.011	N90GPc	LP-S
Mira Platinum Valve and Controller Only (High Pressure)	1.1981.013	N90APv	HP-S
Mira Platinum Dual Valve and Controller Only (High Pressure)	1.1981.014	N90BPv	HP-S
Mira Platinum Valve and Controller Only (Low Pressure)	1.1981.015	N90FPv	LP-S
Mira Platinum Dual Valve and Controller Only (Low Pressure)	1.1981.016	N90GPv	LP-S

Patents and Design Registration

Granted Patents:	GB2568271B, GB2579960B
Granted Design Registrations:	6219329, 6219330, 6219331, 6219332, 6219333, 6219334

Specifications

Standards and Approvals

The Mira Platinum complies with all applicable UK & EU regulations & directives. The Mira Platinum is a type 1 electronic, independently mounted control for surface mounting. Mira Platinum is a thermostatic water mixing valve.

The digital valve and user controller are equipped with Bluetooth® wireless technology. The Bluetooth® word mark and logos are registered trademarks owned by the Bluetooth SIG, Inc. and any use of such marks by Kohler Mira Ltd is under license. Other trademarks and trade names are those of their respective owners.

General	
Pollution Degree	2
Rated Impulse Voltage	2.5 kV
Connections	15mm pushfit
Suitability for Drinking Water Applications	Not suitable
Solenoid Type	Pilot operated
Water Connection Type	Permanent

Mira Digital Mixing Valve High Pressure/Combi (not suitable for pumped gravity systems)

Pressures	
Thermostatic Standard	TMV 2 - HP-S (BS EN 1111 Type 2)
Maximum Static Pressure	1000 kPa (10 bar)
Maximum Maintained Pressure	500 kPa (5 bar)
Minimum Maintained Pressure	100 kPa (1 bar)
Flow Pressure, Hot & Cold - Bar	50 - 500 kPa (0.5 - 5 bar)
Temperatures	
Maximum Temperature (setting range)	30°C - 48°C (Factory Preset 45°C)
Minimum Temperature	Thermostatic control down to 30°C Full Cold also selectable
Recommended Outlet Temperatures	41°C
Hot Water Range - Supply	55°C - 65°C
Cold Water Range - Supply	≤ 25°C
Ambient Temperature	1°C - 50°C
Maximum Relative Humidity	95% non-condensing at 30°C
Electrical Rating	
Supply Voltage	100V - 240V AC 50/60Hz
Maximum Load	38W
Output Supply Voltage to Valve	12V DC

Flow Rates	
Nominal Flow Rate	<p>Minimum flow rate - 4 L/min</p> <p>Under ideal system conditions: Handset products can deliver up to 10 L/min at 1 bar maintained pressure*</p> <p>Overhead products can deliver up to 16 L/min at 1 bar maintained pressure*</p> <p>Default flow rate target: 12 L/min</p> <p>Maximum settable flow rate target: 16 L/min</p>

Mira Digital Mixing Valve Pumped/Gravity (not suitable for mains pressure systems)

Caution! The pump in this product is not suitable for dry running. It is essential you follow the commissioning sequence detail in this guide.

Pressures	
Thermostatic Standard	TMV 2 - LP-S (BS EN 1287 Type 2)
Maximum Static Pressure	1000 kPa (10 bar) 100m head
Maximum Maintained Pressure	100 kPa (1 bar) 10m head
Minimum Maintained Pressure	1 kPa (0.01 bar) 0.10m
Flow Pressure, Hot & Cold - Bar	50 - 500 kPa (0.5 - 5 bar)
Temperatures	
Maximum Temperature (setting range)	30°C - 48°C (Factory Preset 45°C)
Minimum Temperature	Thermostatic control down to 30°C Full Cold also selectable
Recommended Outlet Temperatures	41°C
Hot Water Range - Supply	55°C - 65°C
Cold Water Range - Supply	≤ 25°C
Ambient Temperature	1°C - 50°C
Maximum Relative Humidity	95% non-condensing at 30°C
Flow Rates	
Nominal Flow Rate	<p>Minimum flow rate - 6 L/min</p> <p>Under ideal system conditions: Handset products can deliver up to 10 L/min at 0.1 bar maintained pressure*</p> <p>Overhead products can deliver up to 16 L/min at 0.1 bar maintained pressure*</p> <p>Default flow rate target: 12 L/min</p> <p>Maximum settable flow rate target: 16 L/min</p>

***Note:** Maintained (or dynamic) pressure is the pressure at the valve inlets during operation. Some installations will see a significant pressure drop in the supply pipework when water is flowing, especially when long plastic pipework and small bore fittings are used.

It is recommended to keep supply pipework as short as possible, avoid unnecessary bends and minimise the number of fittings that are used. For longer pipe runs, it may be necessary to increase the nominal pipe size to reduce the pressure drop. Consult a plumbing professional if you are unsure.

If your plumbing system cannot maintain the minimum specified pressure at the valve inlets, you will not be able to achieve the flow rates specified, even if you increase the flow rate target of the product.

Note: Valves operating outside of the manufacturers recommended conditions of use cannot be guaranteed to operate as a TMV Type 2 valve.

Electrical Rating	
Supply Voltage	100V - 240V AC 50/60Hz
Maximum Load	80W
Output Supply Voltage to Valve	12V DC & 24V DC

User Control

Electrical Supply	3.7V DC Internal Battery (rechargeable)
Ingress Protection	IPX5
Maximum Ambient Temperature	40°C

Plumbing Connections

Use below pipework size and type to make connections as listed.

Warning! Use of incorrect pipe types or sizes may cause leaks. Supplied connectors are NOT suitable for 1/2" Pipework. You must use appropriate adapters (not supplied) for 1/2" pipework.

Valve Inlet	15mm Push fit Plastic or Copper (Isolator supplied)
Valve Outlet	15mm Push fit - see below (straight connector supplied)
Overhead (Ceiling Fed or Rear Fed Dual Outlet products)	Ceiling Fed - 15mm Push fit Plastic or Copper (elbow supplied) Rear fed - 15mm Copper Only
Handset supply pipe from valve (Ceiling Fed product)	15mm Push fit Plastic or Copper (Elbow supplied)
Right angled connector (Rear Fed product)	15mm Copper Only

Note: Copper pipe must be used where indicated in the list above. Wherever plastic pipe is allowed make sure to fit the pipe using pipe inserts or as the manufacturer recommends.

Suitable Plumbing Installations

Digital Mixing Valve (High Pressure/Combi Models)

1. Combination boiler systems - the digital high pressure/combi shower can be installed with an instantaneous combination boiler.
2. Unvented mains pressurised system - the digital high pressure/combi shower can be installed with an unvented, stored hot water cylinder system.
3. Mains pressurised instantaneous hot water heater - the digital high pressure/combi shower can be installed with systems of this type with balanced pressures.

Caution! High pressure mixing valves must never be plumbed to gravity or pumped gravity systems. This includes mixed gravity and mains pressure e.g. gravity hot and mains cold. Doing so will invalidate the warranty and potentially cause product and property damage.

Use of Warm-up Feature with Combination Boilers

When using the warm-up feature (see User Guide) with the digital mixing valve supplied via an instantaneous water heater/combination boiler, the user may experience a brief temperature fluctuation. This is caused by the normal operation of a standard instantaneous water heater/combination boiler whereby the boiler will turn off when the flow is stopped (as happens after the warm-up sequence has been completed). Upon restart of the shower, a cold shot will be flushed through followed by a brief hot shot until the hot water supply has stabilised.

Showering Maximum Flow Rate

Combination Boilers

Note: The digital mixing valve can demand hot water quicker than some instantaneous water heaters/combination boilers can provide, especially in winter when the mains water is colder. It is therefore possible this mixing valve will need to have its outlet flow rate altered to match the capability of the water system.

The maximum flow rate can be altered by use of the Mira Showers app.*

High flow rate demanded from low kW combination boilers will result in poor blend temperature stability and could result in your shower going cold. We strongly recommend you to alter the outlet flow rate as the table below.

Boiler Rating	24kW (80,000 Btu/h)	30kW (100,000 Btu/h)	36kW (120,000 Btu/h)
Outlet Flow Rate	8 l/min	10 l/min	12 l/min

Gravity System

A gravity fed hot water cylinder has a finite amount of stored hot water. A standard size hot water cylinder, e.g. 230 Litres, with stored water heated to 65°C will typically provide a showering duration of 30 minutes when the shower temperature is set to mid-blend (approximately 40°C) and at a flow rate of 9 l/min. With the flow rate set to 12 l/min it will reduce the total showering duration to typically 20 minutes.

Once the stored hot water has been depleted, sufficient time will be required for the hot water cylinder to reheat its stored water supply before additional showering time can take place.

The maximum flow rate can be altered by use of the Mira Showers app.*

It may be necessary to alter the outlet flow rate using the Mira Showers app if your stored hot water is running out too quickly. Alternatively reduce the outlet flow by decreasing the flow rate with the user controller.

***Note:** If your water system is not capable of delivering minimum maintained pressure at the valve inlets, you will not be able to achieve the maximum flow rate from your shower even if adjusted via the Mira Showers app. Ensure you have the minimum required maintained pressure at the valve inlets before installation.

Installation Schematic

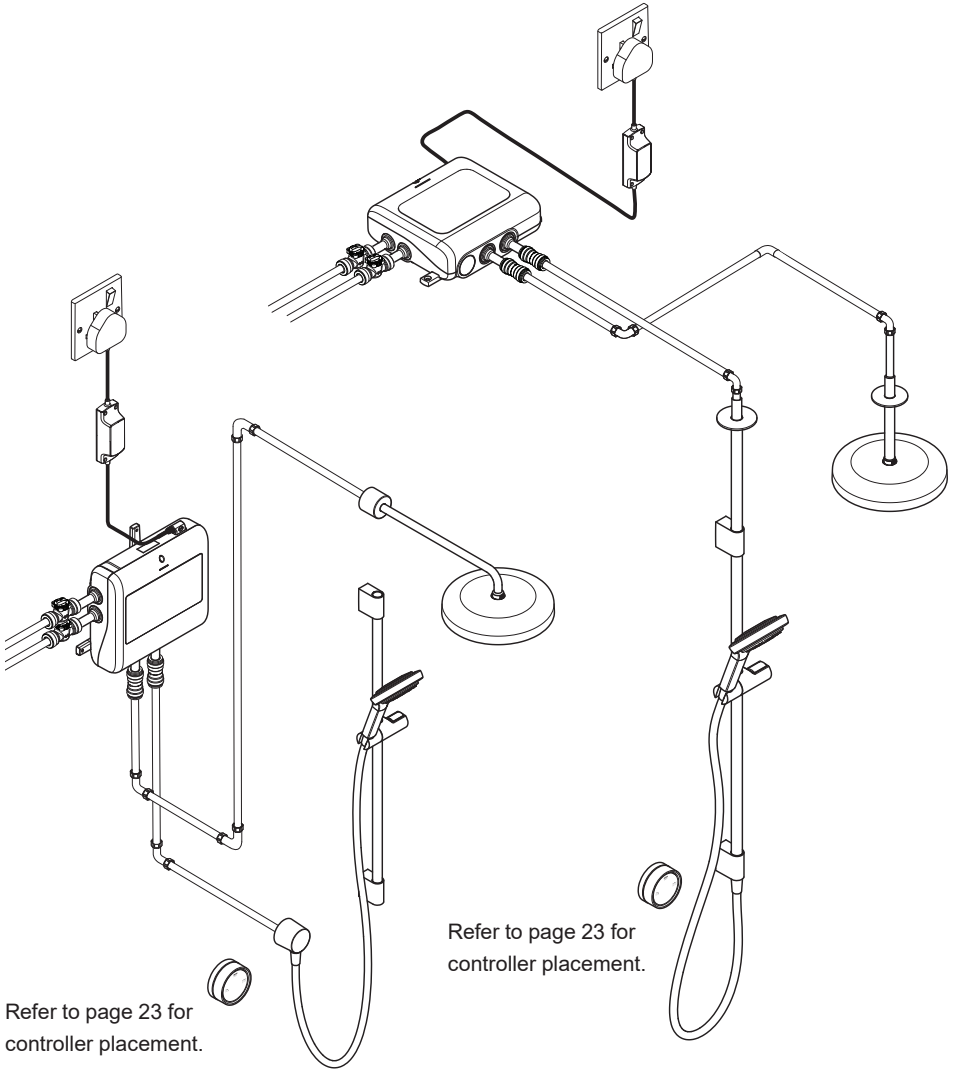

Refer to page 23 for controller placement.

Refer to page 23 for controller placement.

Rear Fed Products

Only use 15 mm copper pipes to make connections to rear fed fittings.

Ceiling Fed Products

Use 15 mm plastic or copper pipes to make connections to ceiling fed fittings.

General Installation

All installations shall comply with the Water Supply (Water Fittings) Regulations 1999, Water Supply (Water Fittings) Regulations (Northern Ireland) 2009, and The Water Supply (Water Fittings) (Scotland) Byelaws 2014.

Safe and easy access to the product should be available at all times.

When installing the product in an area not regularly accessed, consideration for potential leaks must be taken into account. While such events are unlikely, it is advisable to periodically check the installation for traces of water on or around the product.

If possible, site the product in a location where any leak would be contained or routed to avoid areas sensitive to water damage.

Isolating valves must be installed to both inlets (supplied) and it is recommended to fit isolators on the outlet, close to the digital mixing valve for ease of maintenance.

The water supplies to this product must be isolated if the product is not to be used for a long period of time. If the product or pipework is at risk of freezing during this period they should also be drained of water.

Important Installation Considerations

- **DO NOT** site the digital valve where it may freeze, this may cause internal damage and risk a major water leak after thawing.
- Ensure the valve is sited in an area where it meets an ambient temperature between 1°C and 50°C all year round. If fitted in a loft space, consideration must be made to site away from freezing airflow e.g. not sited against outside wall, close to eaves or in an exposed roof.
- Remove any loft insulation directly below valve to allow warm air to rise from property below and fully lag all exposed pipework. Advise the homeowner where the digital valve is sited for future reference.
- Ensure pumped/gravity digital mixing valves showers are not connected to any mains water pressure e.g. stored gravity hot water and cold mains water.
- High pressure/combi digital mixing valves should not be fitted to a gravity or pumped gravity system.
- The digital mixing valve should not be installed where it can become frozen or be subjected to ambient temperatures in excess of 50°C.
- **DO NOT** use any type of jointing paste or compound on any pipework or fittings supplying the digital shower valve. These can build up within the product and reduce the performance or cause early failure.
- Position the digital mixing valve and power supply so that there is enough room for maintenance (e.g. removal of the valve lid and servicing filters through removing inlet pipework) and make sure safe and easy access is available at all times.

Caution! The inlet pipework must be flexible enough to allow 25 mm movement to enable filters to be removed for cleaning and for maintenance of the internal components. Failure to achieve this may result in service and repair not being able to be carried out.

- Supply pipework layout must be arranged to minimize the effect of other outlet usage as shared water supplies may reduce its flow performance upon the dynamic pressures at the digital mixing valve inlets.
- Avoid installations where air locking could occur.
- Cold water cisterns should hold no less than 230 litres and hot water cylinders no less than 210 litres (gravity system only).
- To eliminate pipe debris it is essential that water supply pipes must be flushed prior to connecting the digital mixing valve to the system so debris cannot enter the digital mixing valve internals.
- Fully commission the product after installation taking care to look for any leaks and correct operation. For pumped product, follow commissioning instructions.
- The use of supply-line or zone strainers will reduce the need to remove debris at the digital mixing valve. The recommended maximum mesh aperture dimension for such strainers is 0.5mm.
- Pipework must be rigidly supported and routed such that it does not cause any strain on the connectors.
- Long outlet pipework (dead-legs) should be kept to a minimum to avoid temperature fluctuations.
- The product has integral check valves for the purpose of backflow prevention. These can be replaced if required by following the instructions at the end of this guide.
- **DO NOT** use handsets which have a pause function. Stop the water flow using the user controller.
- **Warning! Ensure use of correct pipe types and sizes. Use of different pipe sizes may cause leaks. See page 15.**

Installation: Digital Mixing Valve

Caution! The digital mixing valve (which contains the thermostatic mixing valve) must be orientated in the positions shown below. Failure to do so will compromise the ability of the unit to fail-safe and deliver constant blend.

- 1 The digital mixing valve may be installed in a loft space, under the bath or in a convenient cupboard space, provided there is enough room for maintenance (e.g. removal of digital mixing valve lid and removal of the inlet pipework to access the inlet filters). Failure to do so may result in an inability to carry out any maintenance.

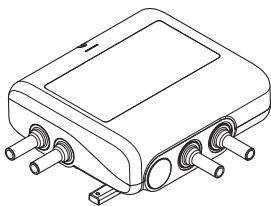

Mounting on a horizontal surface

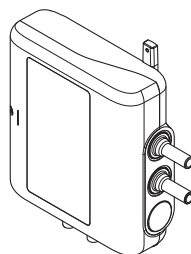

Mounting on a vertical surface

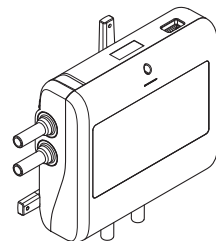

2 Important! Loft Installations - Risk of Freezing.

If installing the digital mixer in a loft space or an area where freezing may occur additional precautions **MUST** be taken to avoid freezing. Frozen valves are likely to experience internal damage and once thawed risk property flooding. Frozen valves and the consequences thereof, are not covered by the Guarantee.

- Ensure the valve is sited in an area where it meets an ambient temperature between 1°C and 50°C all year round. If fitted in a loft space, consideration must be made to site away from freezing airflow e.g. not sited against an outside wall, close to eaves or in an exposed roof.
- For loft installations the valve **MUST ONLY** be installed flat on a horizontal surface.
- Remove any loft insulation directly below valve to allow warm air to rise from property below.
- Insulate the digital valve with a minimum of 200 mm non-combustible insulation that meets a fire rating of **Euroclass A1 to BS EN 13501-1**.
- **DO NOT** use foil type loft insulation as this will inhibit Bluetooth and Wi-Fi signals, which will degrade the communication range between the digital valve, the user interface, and Mira app.
- **DO NOT** insulate the Power Supply Unit (PSU).
- Fully insulate all exposed pipework.
- Advise the homeowner where the digital valve and electrical/water isolation points are sited.

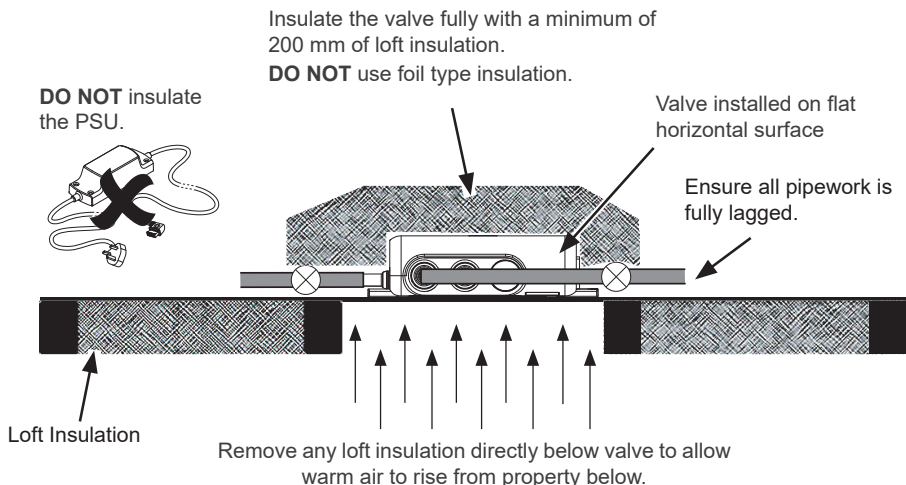

3 Fit the 2 feet in desired location on digital mixing valve using the two Pozi 3.5 x 12mm screws supplied.

Note: There are 4 possible locations to install the feet, depending on your installation constraints.

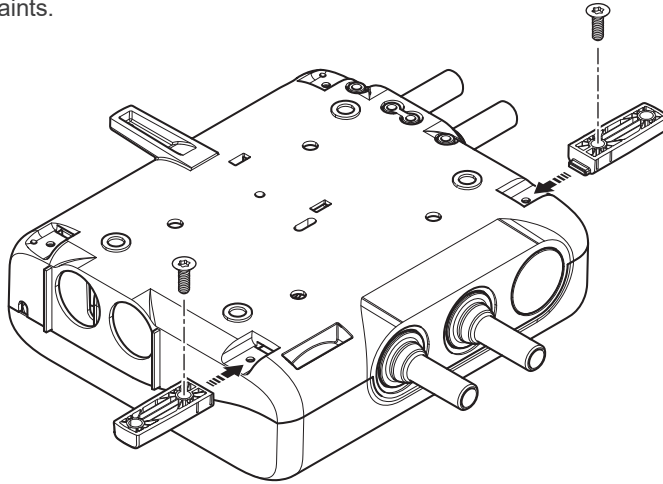

4 Position and Signal Test

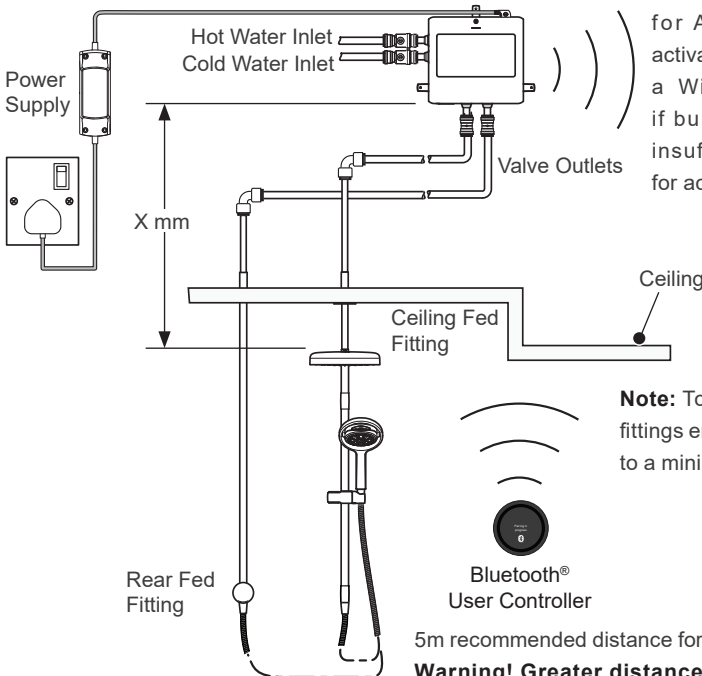

Note: Valve requires connection for App connection, voice activation and software updates, a Wi-Fi extender is available if built-in Wi-Fi capability is insufficient, refer to page 64 for accessories.

Note: To reduce drain down from fittings ensure dimension X is kept to a minimum.

5m recommended distance for best signal.

Warning! Greater distances may result in loss of operation.

Important! When choosing a position for the digital mixing valve in relation to the Bluetooth® controller and the shower fittings, consider the following points:

- The Bluetooth® user controller can be sited up to no more than 5m from the digital mixing valve. However, ceiling and wall thicknesses and construction types may affect the remote signal strength and thereby reduce the range. The controller range should be tested on site prior to installation to ensure reliable control of the shower. If you are unable to position the controller and Valve in locations where they can communicate please acquire the Mira “Bluetooth adapter”. Refer to page 64 for accessories.

Caution! The given wireless range concerns use in the open area, in ideal conditions without any natural or artificial obstacles. The table below shows how obstacles between the receiver and transmitter will cause a drop in signal.

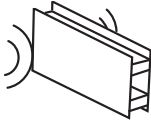
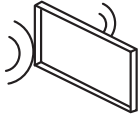
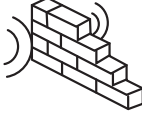
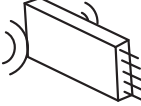
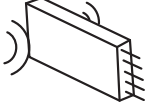
Factors affecting the Bluetooth Signal and Wi-Fi Signals				
				
Wood and Plaster	Glass	Bricks	Reinforced Concrete	Metal
5% - 20%	10% - 20%	20% - 80%	40% - 90%	90% - 100%
Note: Foil backed plasterboard and metallic effect bathroom panelling can dramatically affect Bluetooth signal.				

Over or underground medium and high power lines, radio and television transmitter, GSM transmitter set close to a device system could also decrease range.

- The length of pipework running from the digital mixing valve to the shower fitting will have an effect on the showering temperature and the response time when changing the temperature using the Bluetooth® controller. The shorter the length of pipework from the digital mixing valve the better the shower will respond. It is recommended that this length does not exceed 5m from the valve outlet to shower fitting.
- The ambient temperature of digital mixing valve site (loft space, airing cupboard etc...) can have an effect on showering temperature. Insulate all pipework as required, particularly from the digital mixing valve to the shower fitting.
- The temperature indicated on the Bluetooth® user controller display is measured inside the digital mixing valve and due to site conditions is not necessarily the temperature delivered at the shower outlet.

Note: If it is not possible to position the valve in a strong Wi-Fi signal area for integration with the Mira Showers app, the following is recommended:

1. Purchase the accessory Wi-Fi module extended cable (9.8m) which will allow the Wi-Fi module to be removed from the valve and repositioned in a strong signal area (refer to page 59 for accessories).
2. Purchase a Wi-Fi repeater to extend your Wi-Fi coverage to the valve. Contact your internet service provider (ISP) for more information on compatible models with your home router.

For more support setting up your product with the Mira Showers app, scan the QR code below or visit <https://www.mirashowers.co.uk/connecting-the-app-to-your-wifi/>



- **Caution! Risk of product damage. DO NOT run Pumped Valve (low pressure version) without a water supply for longer than 5 minutes during test.**

a Place user controller in approximate final position (no more than 5m recommended) from digital mixing valve) and press any button to wake the user controller.

Press the 'Pair' button on user controller to start the pairing process.

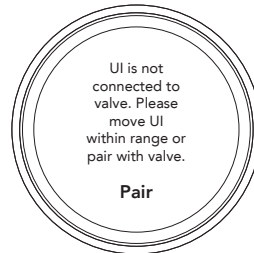
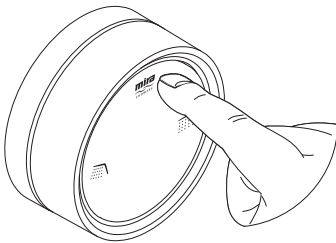

b Connect the power supply to the valve, plug the power supply cable into the mains socket and switch on the power. Wake the controller if necessary and press the 'Start' button on user controller once valve is powered up.

The user controller will start pairing with the valve and show the 'Pairing in progress' message during the process.

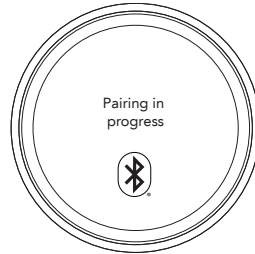
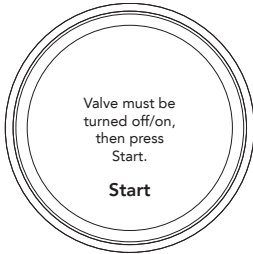

c The user controller will display the signal strength screen once pairing is successful.

d If pairing has failed, the user controller will display 'Pairing failed'. Press 'Retry' to try the pairing process again.

You may need to move the user controller and/or the valve to improve the wireless signal. If you still can't pair the user controller to the valve, contact Customer Services.

	<p>Pale icon: Low Signal Please reposition the controller before installation.</p>						
	<p>White icon: Good Signal Fix the controller to the wall.</p> <table border="0"> <tr> <td></td> <td></td> <td></td> </tr> <tr> <td>Good</td> <td>Better</td> <td>Best</td> </tr> </table>				Good	Better	Best
Good	Better	Best					

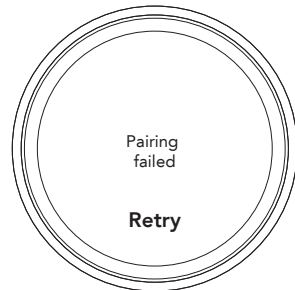

5 Mark the fixing holes in the required positions and secure using suitable fixings.

Note: The valve must be installed on a flat surface.

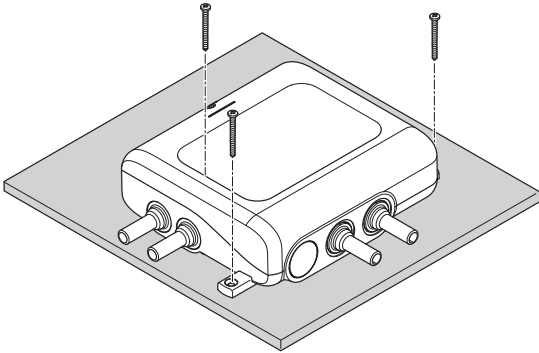

Mounting on a Horizontal Surface

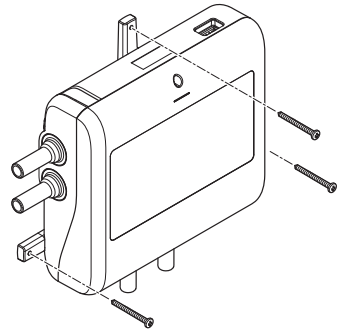

Mounting on a Vertical Surface

6 Connect the hot and cold inlet supply pipework to the digital mixing valve.

Note: DO NOT use any type of jointing paste or compound on any pipework or fittings supplying the digital shower valve. These can build up within the product and reduce the performance or cause early failure.

Note: Only use suitable 15mm pipework when connecting to the push-fit connectors. You must use appropriate adapters (not supplied) for 1/2" pipework. 15 mm plastic or copper pipework must be used as indicated in the 'Plumbing Connections Information' shown in the Specifications Section. Chromed copper, stainless steel or barrier pipe is not suitable for these push fit connectors.

Note: The inlet pipework must be flexible enough to allow 25 mm movement to enable filters to be removed for cleaning and for maintenance of the internal components. Failure to achieve this may result in service and repair not being able to be carried out.

Note: Flush pipework before connecting inlet pipes to digital mixing valve. Failure to flush pipework may cause debris to block filters and impair product performance.

Isolating valves must be installed to both inlets (supplied) and it is recommended to fit isolators on the outlet, close to the digital mixing valve for ease of maintenance.

Run the pipes from the mixed water outlets on the digital mixing valve to the proposed siting for the shower hose outlet, and overhead fixed arm, depending on the system chosen.

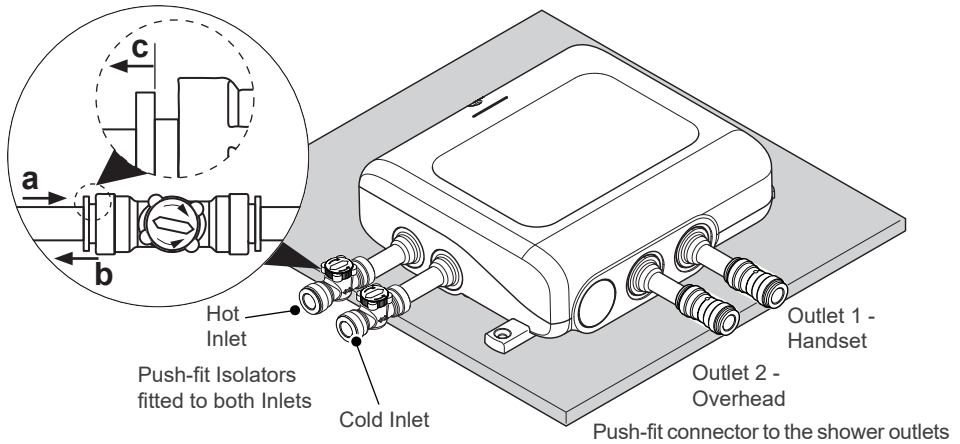

After installing the valve, check the push-fit connectors are correctly engaged.

- a. Ensure every pipe is fully pushed into the internal stop.
- b. Pull the pipework to ensure it is retained and locked in place.
- c. Ensure every locking ring is fully retracted.

7 Install the power supply unit provided, connecting it to the mains socket in accordance with the wiring regulations and permanently fix in place using suitable screws.

Connect the power supply cable to the digital mixing valve and ensure it is firmly in place.

Caution! Before any electrical adjustment is attempted, the electricity supply must be turned off at the mains switch.

Electrical installation may only be carried out by a competent person.

Electrical socket must be easily accessible for maintenance and service.

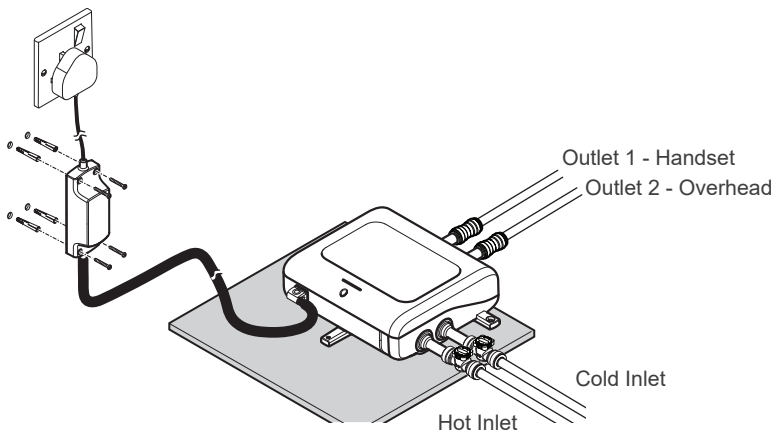

Installation: Ceiling Fed Shower Fittings

Fix at convenient height for all the family. Position the fittings so that water sprays down the centre of the bath, or away from the opening of a shower cubicle. Water should spray away from the user controller when the handshower is held on the slide bar.

1 Decide on suitable position for slide bar avoiding buried cables and pipes in both wall and ceiling. Make sure chrome supply tube will fit through ceiling. Ceiling hole centre can be altered to avoid roof joists by using supplied spacers.

Using template as guide, mark positions of the fixing holes for wall brackets (600 mm). Upper hole to be no more than 645 mm from ceiling.

Note: Use spirit level to make sure fixing holes are vertical.

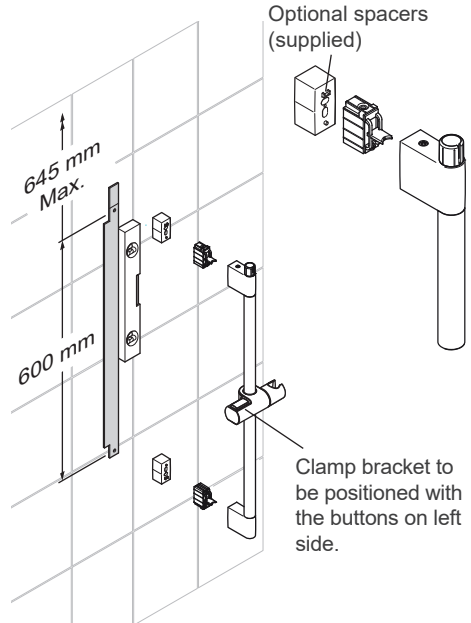

2 Fold long end of template and move up to ceiling. Using upper marked fixing hole as guide, mark centre for hole in ceiling.

Important! If supplied slide bar spacers are required, centre distance for hole will increase to 75 mm from wall. This is to avoid ceiling joists if necessary. Use the supplied longer fixing screws if you are using the spacers.

Drill a hole in the ceiling that is a minimum $\text{Ø}30$ mm maximum $\text{Ø}40$ mm.

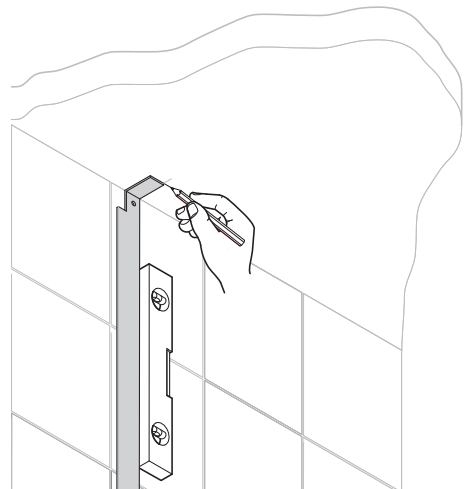

3 Drill into the marked holes to suit the wall fixings. Insert the wall plugs.

Insert fixing screws through holes in wall brackets and fix to the wall. **DO NOT** fully tighten.

Caution! Be aware of hidden pipes or cables.

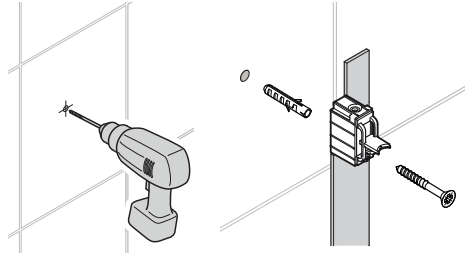

4 Use template to set correct distances between the wall brackets.

Fully tighten the screws. Use longer fixing screws if using spacers supplied.

Note: Slots in wall brackets allow for adjustment. Use one horizontal slot and one vertical slot.

Make sure that holes for slide bar securing screws are positioned correctly, as shown.

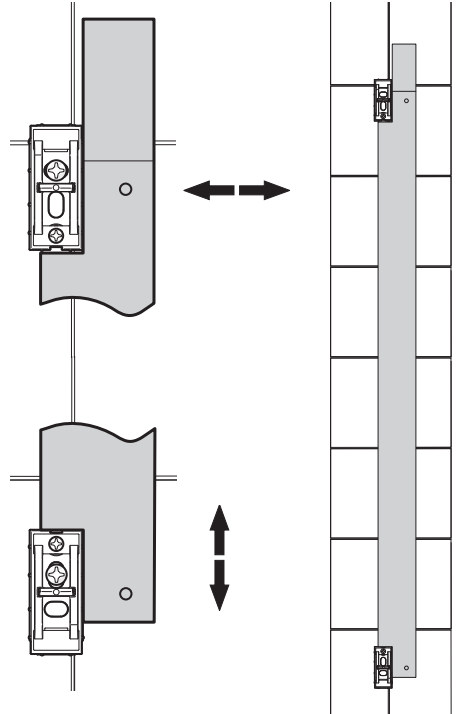

5 Fit ceiling plate and chrome supply tube.

Note: Chrome supply tube may need to be shortened, use a hacksaw to shorten tube. Make sure rough end is concealed in ceiling.

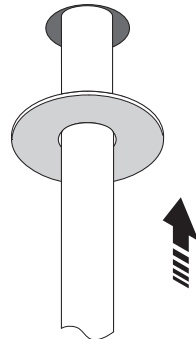

6 Fit the slide bar assembly over the wall brackets and secure with screws supplied. **DO NOT** overtighten.

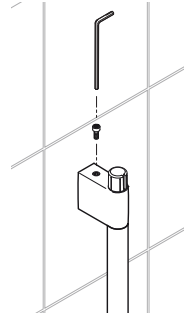

7 Connect the ceiling chrome supply tube.

Feed the plastic pipe up through the slide bar and chrome supply tube into the ceiling.

DO NOT allow any debris to block the plastic pipe.

Note: If plastic pipe requires shortening, make sure there is enough length to fit elbow (supplied).

When shortening for use with any push-fit fitting, follow manufacturer's guidelines for finishing and cleaning the pipe.

Push and twist plastic pipe end until it “clicks” and locks in place.

Connect plastic pipe in ceiling to outlet pipe from valve using elbow supplied. Push all parts together fully.

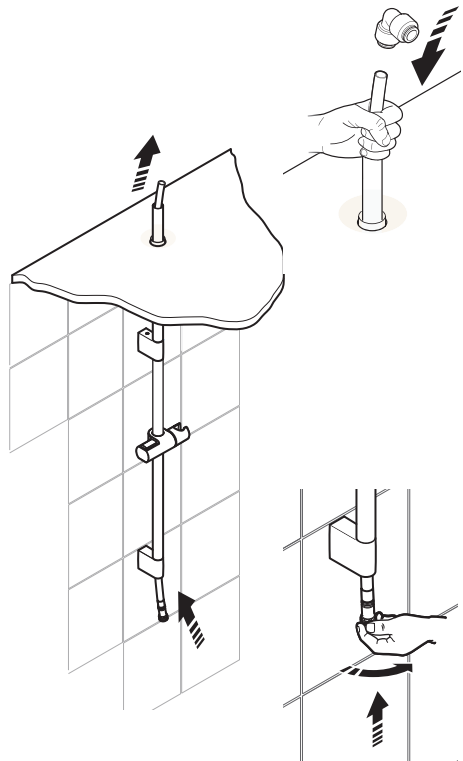

8 Connect elbow to digital mixing valve.

Note: When shortening pipework for use with any push-fit fitting, follow manufacturer's guidelines for finishing and cleaning the pipe.

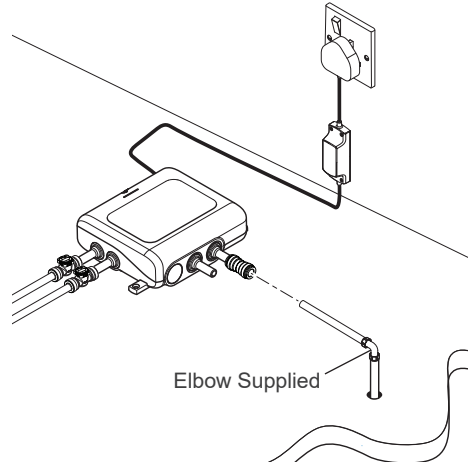

9 Fit the shower hose to the end of the slide bar assembly.

Ensure the washer is in place in both ends of the hose.

Caution! DO NOT fit the handset until pipework has been fully flushed through. Refer to 'Commissioning'. See page 45 for high pressure product, page 46 for pumped product.

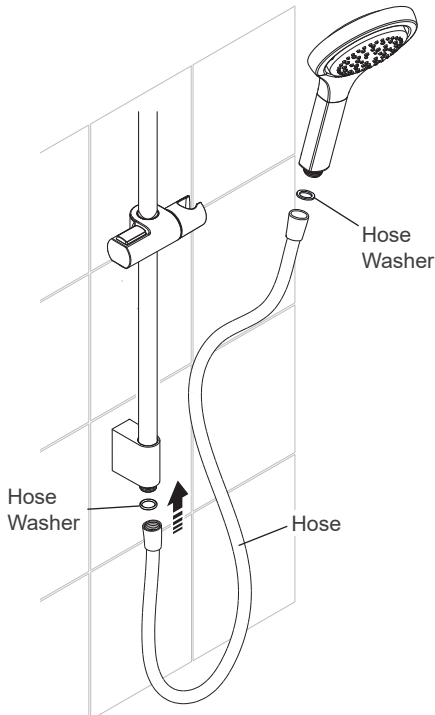

Installation: Rear Fed Shower Fittings

- 1** Fit an isolating valve (not supplied) close to the digital mixing valve for ease of maintenance.

Make sure that the outlet pipe work protrudes approx. 60 mm through a Dia 20 mm hole square to the finish wall surface.

Note: To be trimmed after completion of finished wall surface when installing right angled connector.

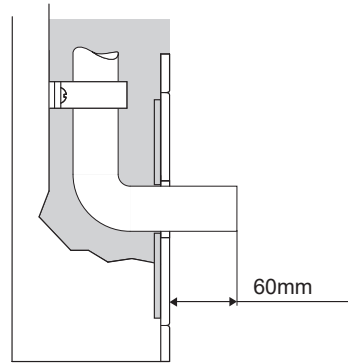

- 2** Finish the surface of the wall as required.

Trim the pipework back to the required depth from the finished wall surface.

Remove all burrs and sharp edges.

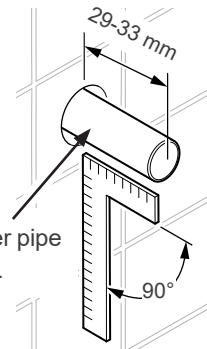

Note: 15mm copper pipe must be used here.

- 3** Disassemble the right angled connector assembly and mark the locations of the screw fixings.

Important! Ensure arrow on backplate is oriented vertical as shown.

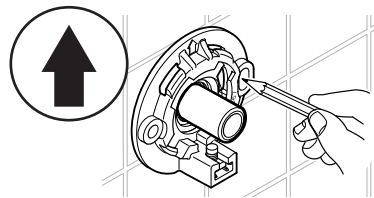

- 4** Drill the fixing holes and fit the wall plugs.

DO NOT drill through the backplate into the wall.

Caution! Be aware of hidden pipes or cables.

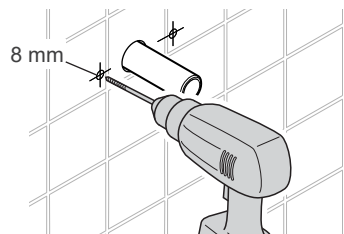

5 Secure the backplate to the wall so the foam seal is fully compressed.

Important! Ensure arrow on backplate is oriented vertical as shown.

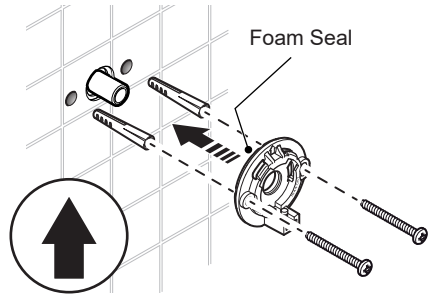

6 Fit the collet and seal retainer.
Re-check the pipe length.

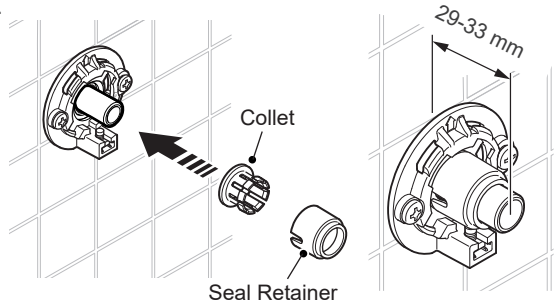

7 Flush pipework to clear all debris.

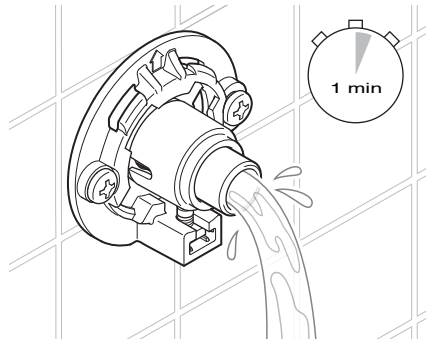

8 Fit the o seal and elbow.

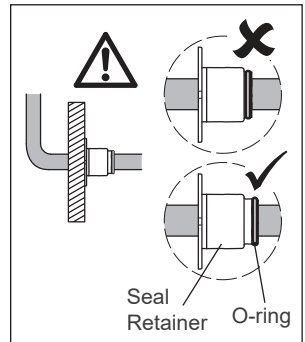
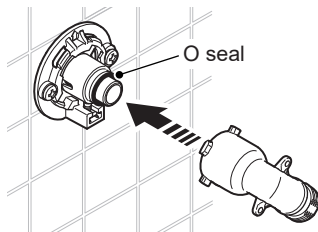

9 Check for leaks.

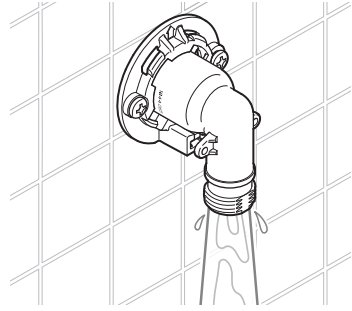

10 Fit the cover. Carefully lift the cover to locate the screw. Unscrew fully to lock using the 2.5 mm hex key supplied.

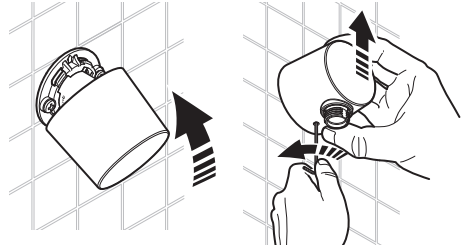

11 The slide bar should be fixed to the wall at a convenient height for all the users. It should be positioned so that water sprays down the centre of the bath, or away from the opening of a shower cubicle. Water should spray away from the Bluetooth® controller when the showerhead is held on the slide bar.

Decide on suitable position for slide bar avoiding buried cables and pipes in wall.

Using template as guide, mark positions of the fixing holes for Wall Brackets (600 mm).

Note: Use spirit level to make sure fixing holes are vertical.

Drill into the marked holes to suit the wall fixings. Insert the wall plugs.

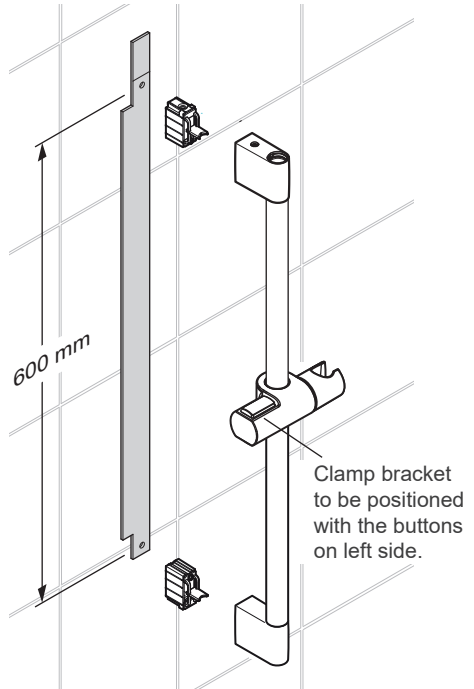

12 Drill into the marked holes to suit the wall fixings. Insert the wall plugs.

Insert fixing screws through holes in wall brackets and fix to wall. **DO NOT** fully tighten at this stage.

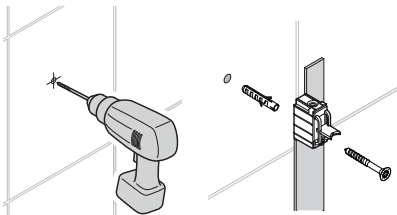

13 Use template to set correct distances between wall brackets. Fully tighten screws.

Note: Slots in wall brackets allow for adjustment. Use one horizontal slot and one vertical slot.

Make sure that holes for slide bar securing screws are positioned correctly, as shown.

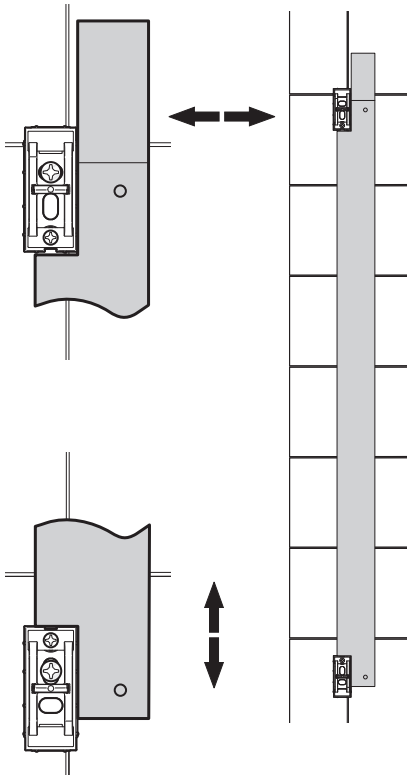

14 Position the slide bar over the wall brackets and secure using the locking screws at both ends of slide bar. **DO NOT** overtighten.

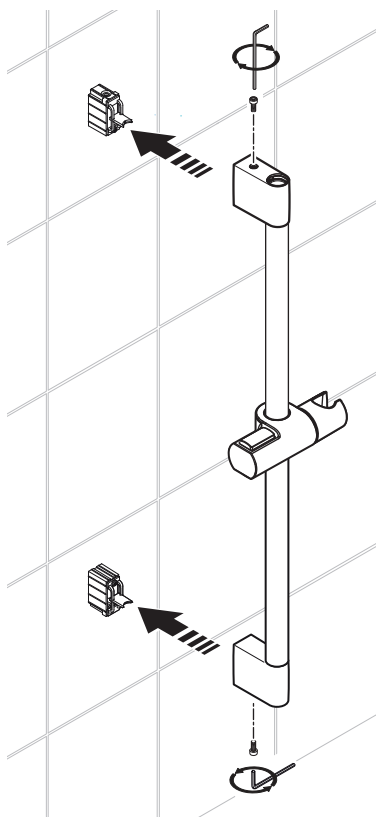

- 15** Fit the slide bar end caps into top and bottom of the slide bar assembly. Push and twist caps until they “click” and lock in place.

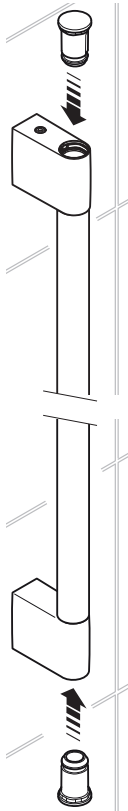

- 16** Fit the one end of the shower hose to the right angled connector assembly and another end to the handset.

Caution! DO NOT fit the handshower until pipework has been fully flushed through. Refer to ‘Commissioning’. See page 45 for high pressure product, page 46 for pumped product.

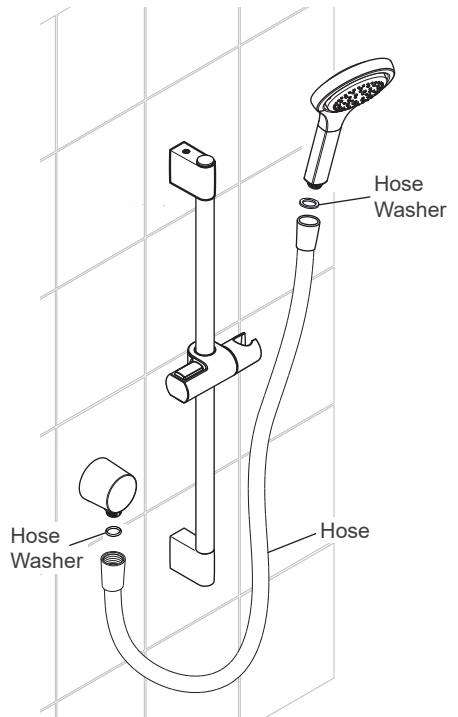

Installation: Deluge Overhead

A. Rear Fed

The shower arm and deluge head should be fitted at a convenient height for all the family. It should be positioned so that water sprays down over the centre of the bath, or away from the opening of a shower cubicle.

- 1 The outlet pipe must protrude 18 mm (± 2 mm) from the finished wall surface and a minimum 35 mm from the ceiling.

Note: Cut the pipe to the correct length and remove any burrs.

- 2 Mark the positions of the backplate fixing holes.

Caution! Be aware of hidden pipes or cables.

- 3 For solid walls, drill the fixing holes for the backplate with a 6 mm drill and insert the wall plugs (supplied). For other types of wall structure alternative fixings may be required (not supplied).

- 4 Carefully fit the backplate over the outlet pipe and secure with the fixing screws (supplied).

Caution! Take care not to damage the O Seal in the back of the backplate.

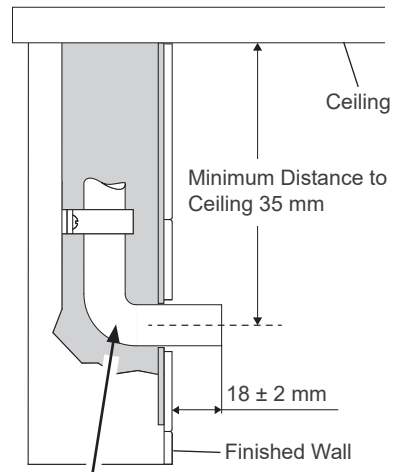
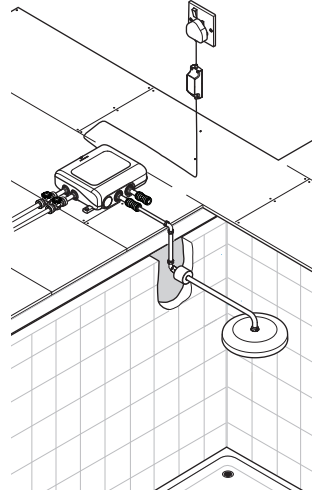

Note: 15mm copper pipe must be used here.

- 5** Fit the olive and compression nipple over the outlet pipe and tighten the compression nipple to $25 \pm 1\text{Nm}$.

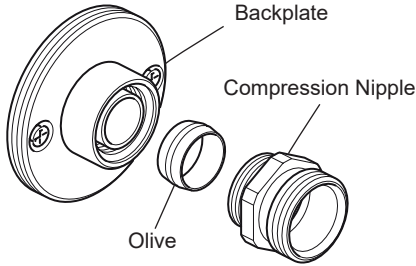

- 6** Fit the concealing shroud onto the shower arm.

Fit the compression nut and olive onto the shower arm.

Fit the shower arm into the compression nipple and tighten the compression nut to $25 \pm 1\text{Nm}$.

Hand tighten the concealing shroud onto the backplate.

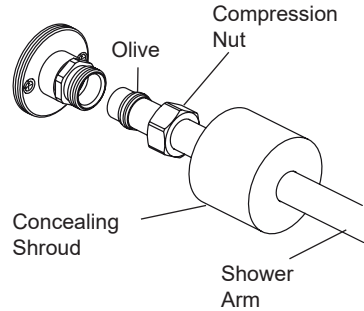

- 7** **DO NOT** fit deluge head after pipework has been fully flushed through. Refer to section “**Commissioning**”. See page 45 for high pressure product, page 46 for pumped product.

Screw the deluge head onto the shower arm by hand.

Note: Use a suitably sized wrench to fully tighten (approximately 1/4 turn).

Caution! The shower arm is not designed to take weight, therefore care needs to be taken when installing the deluge head.

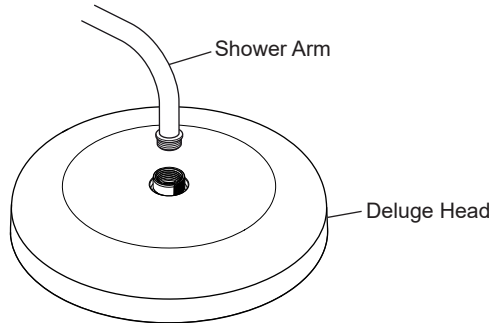

B. Ceiling Fed

The deluge head should be fixed to the ceiling at a convenient height for all the family. It should be positioned so that water sprays down over the centre of the bath, or away from the opening of a shower cubicle.

The fitting of the deluge head into the ceiling will be easier with the aid of a helper.

When you are working within the bath or shower tray area use a towel or blanket to protect the surface from damage.

- 1 Decide on a suitable position for the deluge head avoiding cables and pipes hidden between joists or rafters.

Note: A timber noggin or plywood plinth securely fixed to the joist should be used to mount the deluge head.

Drill a 29 mm hole through the ceiling and the wooden support.

Ensure the two holes drilled are directly in line or the ceiling pipework will be at an angle.

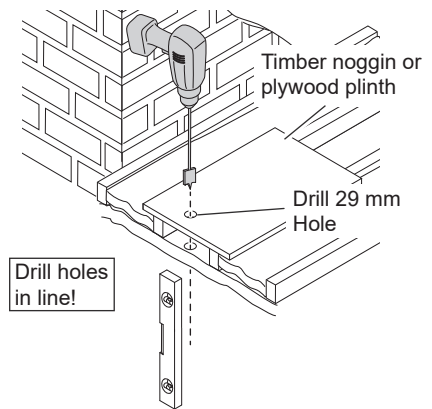

- 2 Push the brazed pipe through the ceiling mount plate then push the threaded end of the brazed pipe down through the holes made in the ceiling.

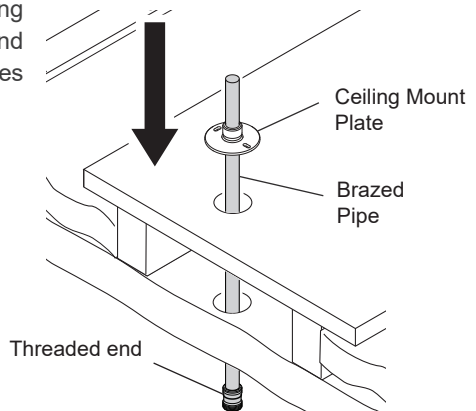

- 3** Centralise the brazed pipe in the hole then screw the ceiling mount plate to the wooden support.

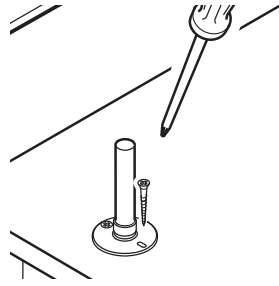

- 4** Offer the deluge head to the brazed pipe and determine the showering height required.

Push / pull the brazed pipe using a twisting motion to adjust the height. Check the height is correct and use a 15 mm pipe cutter to cut the pipe to the desired length.

Note: Cut the brazed pipe at least 30 mm above the ceiling mount plate to allow room to fit the olive, nut and elbow.

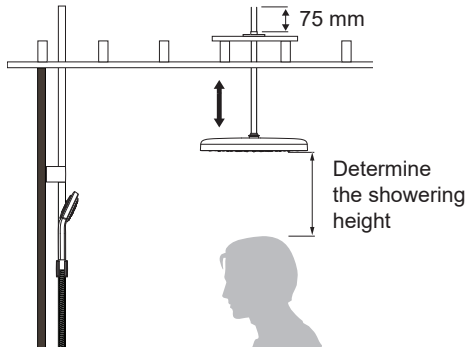

- 5** Secure the brazed pipe to the ceiling mount plate with the olive and 1/2" BSP nut.

Note: This is not a water tight connection, tighten sufficiently to clamp the pipe in place.

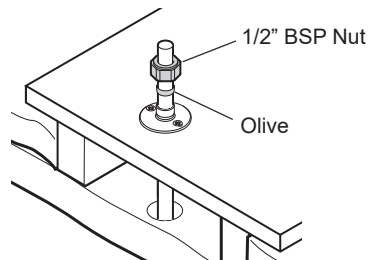

- 6** Offer the chrome supply tube to the brazed pipe and determine the length required to allow the tube to conceal the brazed pipe and protrude into the ceiling space a minimum of 15 mm.

Use a pipe cutter to cut the tube to the desired length. Remove all burrs.

Note: Take care not to crush the pipe when cutting.

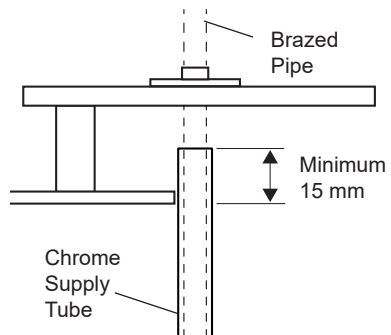

7 Push the cut end of the chrome supply tube into the concealing plate then slide the chrome supply tube over the threaded end of the brazed pipe and up through the hole until the concealing plate is secured in the hole and the concealing plate is flat against the ceiling.

Note: If the hole in the ceiling is oversize use silicone sealant on the underside of the concealing plate to retain it.

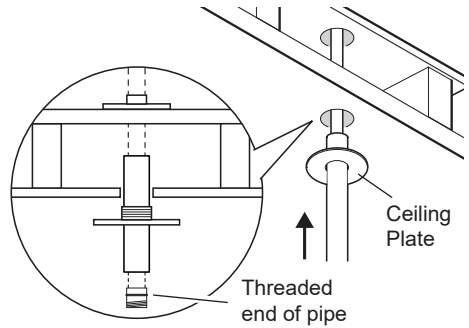

8 Connect brazed pipe in ceiling to outlet pipe from digital mixing valve using elbow supplied. Push all parts together fully.

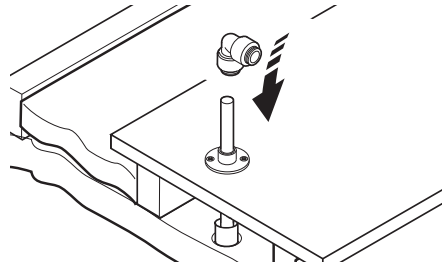

9 Connect elbow to digital mixing valve. Follow manufacturers guidelines for fitting alternative push-fit connections and flexible pipework.

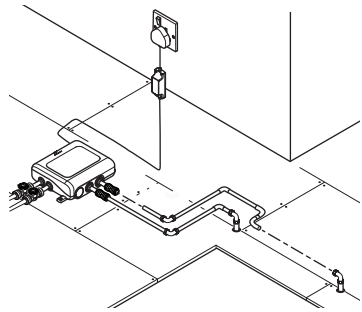

10 DO NOT fit deluge head until pipework has been fully flushed through. Refer to section “**Commissioning**”. **See page 45 for high pressure product, page 46 for pumped product.**

Screw the deluge head onto the brazed pipe outlet by hand.

Note: Use two suitably sized wrenches to fully tighten (approximately 1/4 turn).

Slide the chrome supply tube down to conceal the brazed pipe.

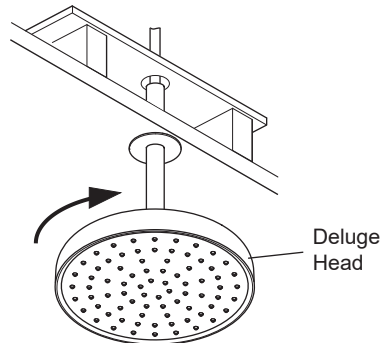

Installation: User Controller

- 1** Suitable for solid, dry-lined, stud partition, shower cubicle or laminated panel walls. The user controller should be fixed to the wall at a convenient height for all the family. It should be positioned so that water does not spray over it when the showerhead is held on the slide bar.

Important! Make sure the Bluetooth signal has been tested between user controller and digital mixing valve before permanently fixing to wall. See section 'Position and Signal Test' on page 23.

- 2** Mount the cradle on flat surface and mark the position for cradle holes. **Important! Ensure arrow on the cradle is oriented vertical as shown below.**

Drill the fixing holes and fit the wall plugs. **DO NOT** drill through the cradle / backplate.

Caution! Avoid drilling through buried cables or pipes.

Make sure surface is clean and dry. Fix the cradle to finished wall surface.

Note: Use silicone sealant around wall fixing screws to prevent water ingress.

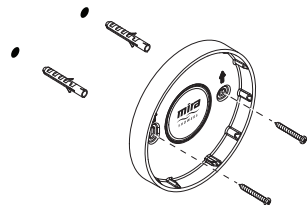
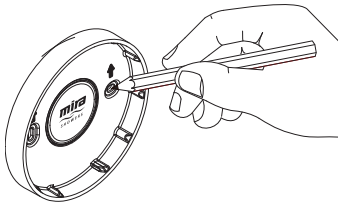

- 3** Hook the user controller on top of the cradle and push into place.

Warning! This appliance contains magnets. Users fitted with a heart pacemaker or ICD should follow their normal safety precautions for products that contain magnets. The magnets are located in the User Controller and Cradle. There are no magnets in the showerhead.

Note: It is recommended to charge the controller prior to installation.

- 4** Press the Mira showers logo to wake up the user controller and check that the connection with the valve is still in place.

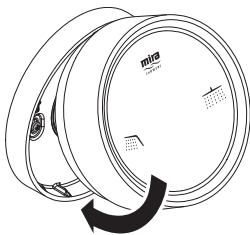
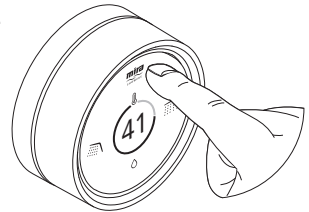

Note: To release the user controller, ensure there is no water present and remove the controller by lifting the bottom section from the cradle.

Warning! Knocking the controller from the cradle may result in the product being inoperable. This is not covered under warranty.



Commissioning Checklist

Ensure all items on the below checklist have been ticked off prior to commissioning.

- The designation of the thermostatic mixing valve matches the application.
- The supply pressures are within the valve's operating range.
- The supply temperatures are within the valve operating range.
- The temperature differential is appropriate for the supply conditions.
- Isolating valves are fitted, accessible and open.
- Strainers are fitted and clean.
- Appropriate Backflow prevention devices are fitted.

If all these conditions are met, proceed to set the mixed water outlet temperature at the recommended outlet temperature by following the manufacturer installation instructions.

Commissioning (High Pressure Product)

Warning! For the Pumped low pressure valve you must follow the separate valve commissioning sequence on page 46.

- 1 Turn on the water supply and open water inlet supply isolators.



- 2 Turn on the electrical supply to digital mixing valve.
The digital mixing valve will power and perform a self check where the LED will indicate a RED light initially and will then change to BLUE light after a few seconds.
Note: If the LED does not turn to a solid BLUE light after 10 seconds, indicating the product is ready to use, refer to the troubleshooting or fault diagnosis section.

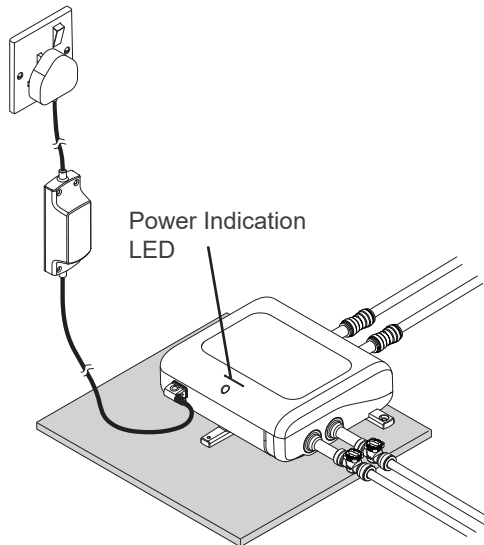

Note: Refer to the “Using the Controller” section on page 49 for the next steps of product commissioning.

Commissioning (Pumped Product)

Warning! Silent pump cannot be dry run for extended period.

1 Ensure all items on the below checklist have been ticked off prior to commissioning.

- This is a gravity system product, do not install on a mains pressure system.
- Ensure product is installed in a recommended orientation.
- Ensure pipework is completely free of airlocks & dead legs.
- Ensure pipework is flushed.
- Ensure supplies are correctly plumbed, are on & tanks full.
- Ensure handset is removed, hose dropped & directed to waste.

Note: The Mira Wireless Remote Accessory will not operate until commissioning has been completed.

2 Turn on the water supply and open water inlet supply isolators.

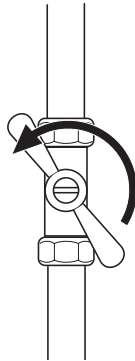

3 Turn on the electrical supply to digital mixing valve.

The digital mixing valve will power and perform a self check where the LED will indicate a RED light initially and will then change to a BLUE/RED flashing light after a few seconds.

Note: If the LED does not turn to a BLUE/RED flashing light after 10 seconds, indicating the product is ready to commission, refer to the troubleshooting or fault diagnosis section.

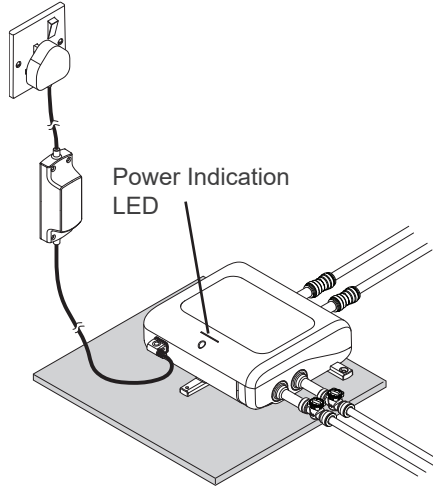

4 **Commissioning Required.**

The controller will indicate commissioning is required. Ensure the checklist is completed and initiate commissioning by pressing 'Start'. Do not leave the product unobserved during commissioning. If you need to abort the process, press 'Cancel'.

5 **Indicate Flow.**

Wait for water to flow from the end of the hose, then move on to the next step by pressing the flashing handset button on the user controller. The product may proceed by itself if your water pressure is sufficient.

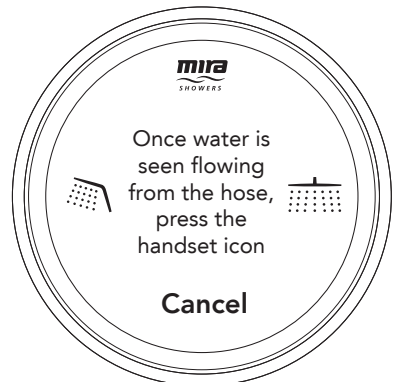

6 Pump Commissioning.

The product will then commission the pump. Wait for this to be completed. A noisy pump is indicative of a lack of water – this may suggest supply issues. The product will indicate when the process is complete. Press 'Done' to move on.



7 Failed Commissioning.

If commissioning has cancelled or failed, the product will indicate this. Please check inlet pipework and retry. Failures can be caused by partially opened isolators or airlocks.

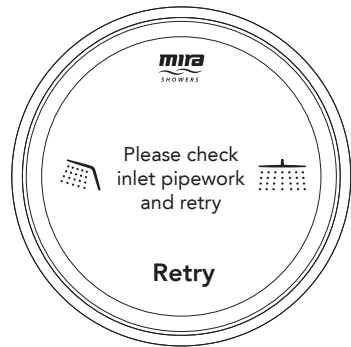
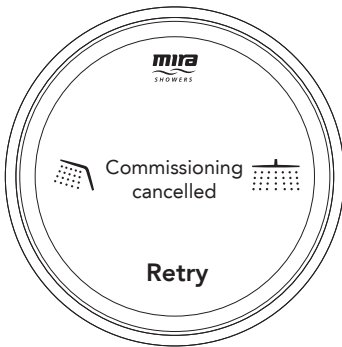

8 Recommissioning.

If recommissioning is required at any point in the future, this can be completed using the Mira Showers app or settings menu on the controller.

Using the Controller

- 1** Start the shower by pressing the outlet icon buttons.

Note: On a dual outlet product, both outlets can run at the same time but the flow will be shared.

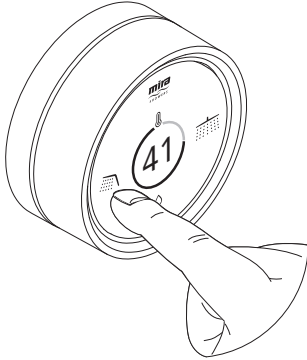

- 2** Adjust the temperature by rotating the bezel.

Clockwise - Increases the temperature

Anti-clockwise - Decreases the temperature

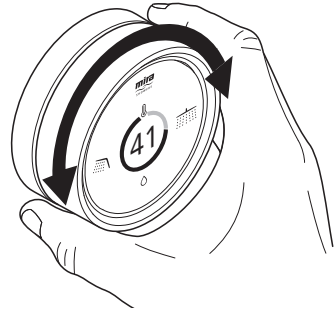

- 3** Adjust the flow by pressing the flow button and then rotating the bezel.

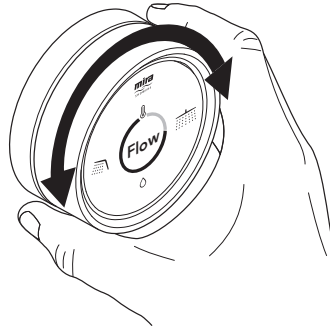
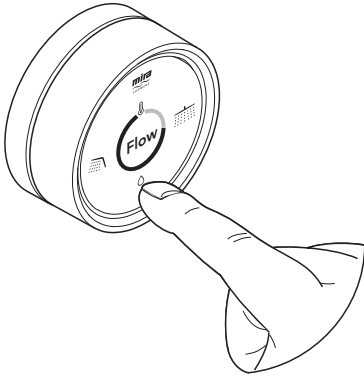

- 4** Verify the mixed water outlet temperature. After confirming the accuracy of the mixed water outlet temperature, it is recommended to verify its stability by repeatedly turning the mixing valve on and off and rechecking the mixed water outlet temperature. If the temperature remains constant, proceed to the cold-water isolation test.

Turn off the shower by pressing the outlet icon button.

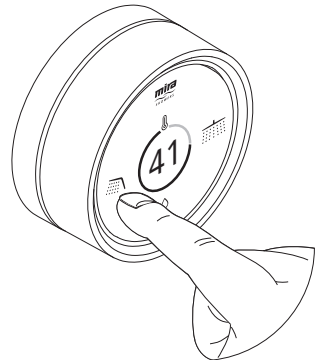

Cold Water Isolation Test

Verify that the thermal performance of the mixing valve is adequate at the time of installation and annually thereafter.

1. Operate the mixing valve and achieve a normal flow rate for the application and record the initial mixed water outlet temperature.
2. Isolate the cold-water supply to the valve.
3. Collect the water discharged from the mixing valve outlet for 5 seconds.
4. Continue to collect the water discharged from the mixing valve outlet in a second vessel for a further period of 30 seconds.
5. Re-open (restore) the cold-water supply and after 30 seconds measure the mixed water temperature.

Acceptance Criteria:

- The volume collected in the first period of 5 seconds shall not exceed 200 ml.
- The volume collected in the second period of 30 seconds shall not exceed an additional 300 ml.
- After restoration of the cold-water supply (30 seconds) the mixed water outlet temperature shall not differ by more than 2°C from the initial set mixed water temperature.

In-service Testing

It is recommended that all TYPE 2 approved valves are tested and evaluated against the commissioning setting results once a year. Whilst this is a recommendation in user / owner domestic dwellings, a duty of care obligation should be considered in commercial bathroom or subletting situations. When in-service testing is undertaken the following performance checks shall be carried out.

1. The supply conditions (temperatures & pressures) are broadly the same as they were at the time of installation.
2. Measure the mixed water temperature at the outlet(s).
3. Carry out the cold-water isolation test.

If there is no significant change to the set outlet temperature ($\pm 2^{\circ}\text{C}$ or less change from the original settings) and the cold-water isolation test criteria is achieved, then the valve is working correctly, and no further service work is required. If the performance falls outside of that acceptance criteria, then service or adjust the valve in line with the manufacturer's instructions.

Notes: If there is a residual flow during the commissioning or the annual verification (cold water supply isolation test), then this is acceptable providing the temperature of the water seeping from the valve is no more than 2°C above the designated maximum mixed water outlet temperature setting of the valve.

Temperature readings should be taken at the normal flow rate after allowing for the system to stabilise.

The sensing part of the thermometer probe must be fully submerged in the water that is to be tested.

Any thermostatic mixing valve that has been adjusted or serviced must be re-commissioned and re-tested in accordance with the manufacturers' instructions.

User Controller: Features

A. Accessing the presets and menu system

- 1** Press the 'Mira logo' to access the sub menus.

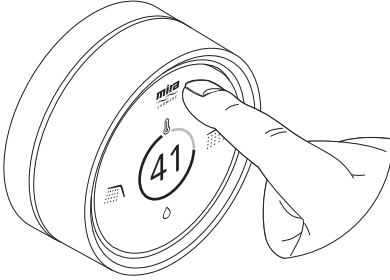

- 2** Rotate the bezel to select the desired sub menus. Here you can access presets, timer and settings options. Navigate to the presets icon and press 'Select'.

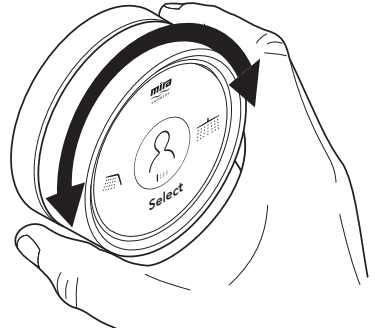

- 3** Rotate the bezel clockwise to scroll forward and anticlockwise to scroll backward through the available presets. Press 'Select' to choose the desired preset.

You can scroll forward to 'Exit' and press 'Select' or the 'Mira logo' to return to the main menu.

- 4** Press the 'Start' button to activate the preset outlet(s), temperature, flow level and shower duration.

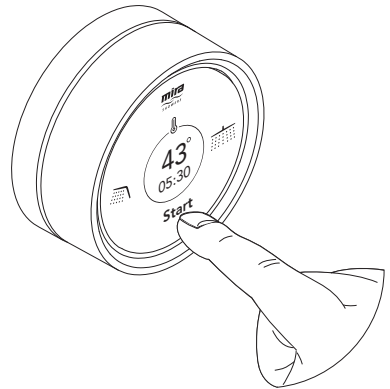
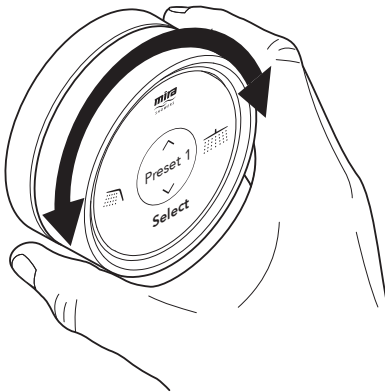

- 5** The display shows how long the preset shower has left to run.
Press the running outlet button to stop the shower at any time.

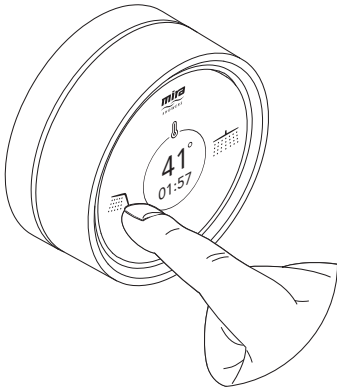

- 6** During the final 15 seconds the controller is active and the 'Extend function' is available.
Press 'Extend' to continue showering.



- 7** Once extended, the display will show the temperature screen and the shower will run normally.

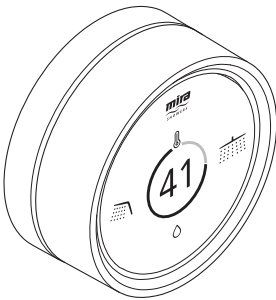

- 8** The dashboard will appear at the end of the shower displaying the usage and battery level.
The dashboard display will timeout after 7 seconds.

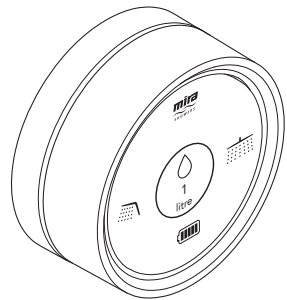

B. Settings menu

The settings menu is accessible via the main menu. The menu can be navigated by using the rotary bezel to scroll through items; the item can then be entered by pressing 'Select'. Selecting 'Exit' at the end of the items or pressing the 'Mira logo' will return to the main menu.

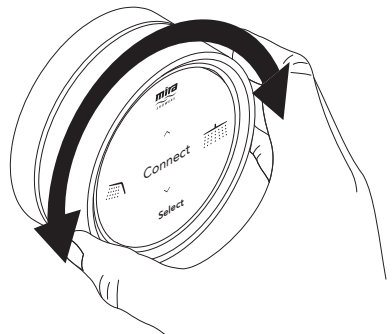

Setting	Description	Variables
Maximum Flow	Sets maximum flow rate	High pressure valve - 4-16 lpm. See page 13.
		Pumped for gravity valve - 6-16 lpm. See page 14.
Minimum Flow	Sets minimum flow rate	High pressure valve - 4-16 lpm. See page 13.
		Pumped for Gravity valve - 6-16 lpm. See page 14.
Maximum Temperature	Maximum temperature setpoint	30° - 48°
Warm-up	Enables warm-up and delayed start	On/Off
Display Brightness	Set display brightness	Low / Medium / High
Display Mode	Sets screen illumination time	Eco / Normal / Extended / Full
Start/Stop	Sets press requirement to start the shower	Double press/Single press
Hot Water Low Warning	Controls whether the "incoming temperature too low" is reported.	Enabled / Disabled
Battery Level	Displays battery level	-
Signal Level	Displays the current BLE signal level	-
Forget Valve	Un-pairs user controller from valve	-
Add device	Add bluetooth device to shower	-
De-register System	Disconnects valve from the Internet	-
Re-start Valve	Restarts valve and user controller	-
Factory Reset	Factory resets valve and user controller	Confirm
Re-commission	Re-starts the LP commissioning process. See page 46.	-
About	Displays Valve, User Controller software and Bluetooth software version number	-
Exit	Returns to the main menu.	-

Caution! The MENU system for settings can only be accessed when the shower is in the OFF state.

Note: Some menu items may not be displayed dependent on how the system is configured.

Note: If active, Warm-up mode can be overridden by pressing the required outlet buttons three times when starting.

C. Charging the User controller

1 The user controller screen will indicate if charging is required at the end of a shower by showing the following screens. **Note:** Only charge the controller when prompted to ensure battery longevity.

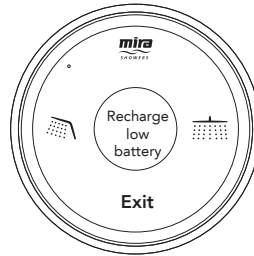
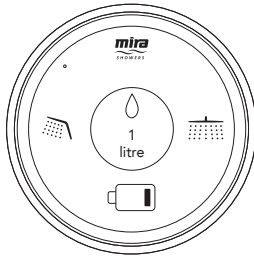

2 Ensure the shower is OFF and remove the controller by lifting the bottom section from the cradle.

Warning! Knocking the controller from the cradle may result in the product being inoperable. This is not covered under warranty.



3 In a dry environment carefully pull out the bung from the underside of the controller. Insert the provided charging cable into the USB connector and a power source.

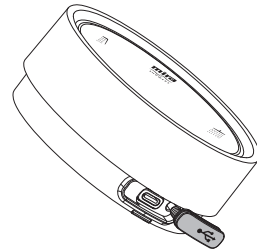

Important! Only USB C power + data cables and minimum of 5W power supply are compatible with the controller.

4 The charging LED will illuminate red and the display will show a moving segment battery symbol, both indicating that charging is in progress. The display will fade out after few seconds.

At the end of the charge, the red light will change to green, indicating charging is complete, and will continue to show until the charger is disconnected.

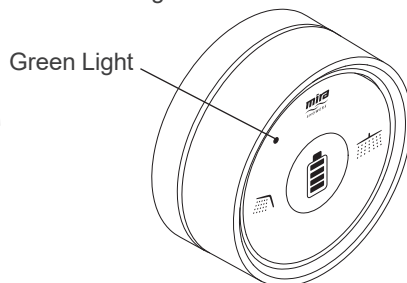
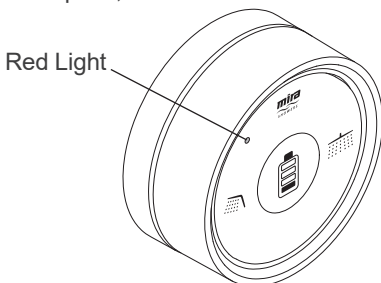

- 5** Disconnect the charging cable and re-insert the bung making sure it sits firmly in place. Locate the controller back onto the cradle as removed making sure the top hook feature locates into the cradle.

Warning! Failure to correctly reinsert the USB bung will lead to water ingress and possible component failure.

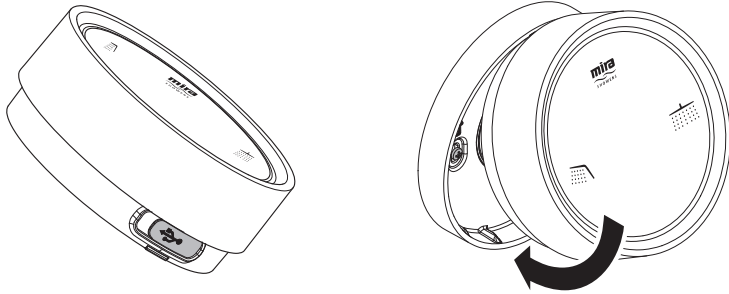

Set Up: Mobile App

You can set up and customise your shower using your Apple iPhone or Android Phone with the companion Mira Showers app.

- 1** Download the Mira Showers app from appropriate app store for your device.



Note: Not all Apple or Android devices are compatible - please refer to the relevant app store compatibility listing for more details and ensure your device's Operating System has the latest updates installed.

Mira endeavour to ensure that the Mira Showers app is compatible with the latest versions of Apple and Android Operating System. If your device is not capable of running the latest versions of Operating Systems the Mira Showers app may NOT be compatible with your device. Please ensure your mobile device is configured for automatic app updates to ensure that the Mira Showers app is kept up to date with the latest bug fixes and performance enhancements.

Your shower can be set up either by using the controller or via the Mira Showers app. See **“Position and Signal Test”** section on page 23.

2 Once the Mira Showers app has been installed, open the app on your device and follow the on-screen instructions to connect your phone to your Digital Mixing Valve.

3 You can then use the Mira Showers app to customise and control your Digital Mixing Valve remotely.

Warning! Never remotely operate or alter any of the Mira Platinum shower settings if it is already occupied and / or being used by another person or if you are not in the vicinity of the outlet. This could result in flooding of the shower cubical or scalding of the user.



For additional information and support with the Mobile App please scan the QR code or visit <https://www.mirashowers.co.uk/your-shower-in-your-hands-the-mira-showers-app/>

Set Up: Wi-Fi Connection

Your Mira Platinum product contains Wi-Fi connectivity which, when configured/'provisioned' through the Mira Showers companion app, allows your product to connect to the app, update itself with the latest features and bug fixes, connect to your Google/Amazon smart speakers for voice command operation and also optionally track your household water usage over longer periods of time.

Provisioning should be carried out by the household/product owner and will link their user account to the product as the primary user. This process is completed through the step by step instructions within the mobile app.

Once provisioned, it is possible to view your usage data/configure your product using your mobile device anywhere with an internet connection and when not within the vicinity of your Mira Platinum. It is the homeowner's responsibility to ensure that no accidental operation (either via the app or connected smart speakers) will result in flooding as a consequence of this.

Warning! If planning to change internet service provider (ISP), router or Wi-Fi credentials (SSID/password), it is important to remember to first de-register your Mira Platinum product from the internet prior to making changes. To do this, enter the Settings menu of the User Controller and scroll down to 'De-register' and select. Alternatively, you can de-register your product by deleting the product entry within the Mira Showers mobile app.

In the event of a change to internet service provider without de-provisioning first, a new Wi-Fi module will be required which is a chargeable spare part.



For more support setting up your Wi-Fi, scan the QR code or visit <https://www.mirashowers.co.uk/connecting-the-app-to-your-wifi/>

Fault Diagnosis

Read the section “**Important Safety Information**” first. As with most electronic equipment resetting the digital mixing valve by powering it down waiting a few seconds then powering it up again can often cure most issues.

Providing the digital mixing valve has been correctly installed and is operated in accordance with the instructions contained in this guide, difficulties should not arise. If any maintenance is required, then it must be carried out by a competent tradesperson. Before replacing any parts make sure that the underlying cause of the malfunction has been resolved.

Warning! There are no user serviceable components beneath the cover of the appliance. Only a competent tradesperson should remove the cover.

The digital mixing valve has built-in sensors to help diagnose system and product issues. To access these advanced diagnostics features, please download the Mira Showers app (see section “Set Up: Mobile App”).

Please follow this self-diagnosis section to be sure the product is at fault before contacting Mira.

Diagnosis stage 1 (Error code check):

In the first instance, check your product has no error warning displayed on the controller. You can also check for error codes on the Mira Showers app.

Only some errors are displayed on the controller. You will need to download the Mira Showers app for full diagnosis and error functionality.

If you have an error code not listed below, or if the errors continue to occur after it has been reset, please contact Mira customer services team to resolve the issue.

If you do not have an error code, proceed to Diagnosis stage 2

Error Code	Description and remedial action
3, 7, 9	Outlet temperature too hot. Try powering off the product for 30 seconds or resetting in the Mira Showers app or using the controller menu option. Refer to diagnosis section 4d.
4	Outlet thermistor not detected - contact Mira customer services team.
11 or 111	DO NOT ATTEMPT TO OPERATE YOUR PRODUCT. A temperature of less than 0°C has been detected in your product which could have caused internal damage leading to potential leaks. It is essential that your product is protected from freezing conditions otherwise serious damage can occur. Warning! If the valve module has been subjected to freezing conditions it may require inspection to ensure internal damage has not occurred, (contact your installer). If no sign of leaks, reset the product by powering off for 30 seconds or re-setting in the Mira Showers app or using the controller menu option. Ensure there are no leaks when shower first used.
37	Hot water temperature spike detected - Turn off the product to maintain safety. Check incoming water temperature is within specification and restart product. Refer to diagnosis section 4d.

Error Code	Description and remedial action
40	A software error has been detected. Try powering off the product for 30 seconds or resetting in the Mira Showers app or using the controller menu option.
45	An outlet solenoid error has been detected. Try powering off the product for 30 seconds or resetting in the Mira Showers app or using the controller menu option.
50	No (or very low) flow has been detected by the product. This can be caused by the inlet water supply being isolated or restricted. Check isolators are open and that the filters or handset and hose are not blocked. Resolve the issue then reset error by powering off the product for 30 seconds or resetting in the Mira Showers app or using the controller menu option. Refer to diagnosis section 4b.
53	Flow has been detected when the product should be off. Try powering off the product for 30 seconds or resetting in the Mira Showers app or using the controller menu option. Refer to diagnosis section 4c.
54	Unusually high flow has been detected. Try powering off the product for 30 seconds or resetting in the Mira Showers app or using the controller menu option.
55	User controller stuck button detected. Check that your user controller is free to move and then power off the product for 30 seconds or reset the product in the Mira Showers app. If the error re-appears please contact Mira customer services team.
110	Hot Inlet thermistor not detected - contact Mira customer services team.
112	A hot inlet water temperature above the specification has been detected. This can cause dangerous temperature spikes or product damage. Resolve the issue then reset error by powering off the product for 30 seconds or resetting in the Mira Showers app or using the controller menu option.

Diagnosis stage 2 (Valve status check):

If you do not have an error code, or if the controller is not functional you should then check the status indicator light on the product.

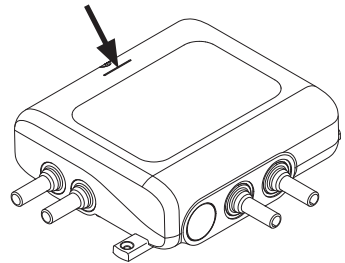

Power Indicator Status	Description
Blue	Product should be functional. If your product is still exhibiting problems continue to Diagnosis stage 4.
Red	Product has an error. Follow Diagnosis stage 1 or continue to Diagnosis stage 4. Note: Red light illuminates for first 5 seconds after power-up.
Flashing Red/Blue	(Pumped Product Only) Product is in priming sequence. Follow the commissioning sequence in "Commissioning Section".
Off	Product is not receiving power. See Diagnosis stage 3.

Diagnosis stage 3 (No Power to the product):

1. Check the product is plugged in and switched on.
2. Check the power connector from the power supply is securely connected into the back of the digital mixing valve.
3. Check the circuit breaker or RCD in your consumer unit has not tripped.
4. Check the fuse and replace if necessary (3 Amp).
5. Contact Mira Customer Service Team if none of the above restored power to the digital mixing valve.

Diagnosis stage 4 (Product powered, but no error code):

If you have a problem with your shower but do not have an error code, find the relevant section below and follow the recommendations before contacting Mira.

4a - No Flow / Low Flow:

Low flow through the product normally indicates a restriction in the system, or incorrect system pressures.

1. Check there are no digital mixing valve errors (**Diagnosis stage 1**).
2. Check the flow on the controller is not set too low. Check Min and Max settings.
3. Check the inlet isolators to the digital mixing valve are fully open.
4. For mains-fed (High Pressure / Combi) products, check that the incoming supply to the property is not too restrictive. Fully open the stop cock and check that the 'Pressure Reducing Valve' (if fitted) is not set too low. Refer to the 'Minimum maintained pressure' requirement for your product.
5. Check and clean the inlet filters (refer to "Cleaning and Maintenance Section").
6. Check for restrictions in the shower head / hose and clean or replace if necessary.
7. Use the Mira Showers app to check your hot water temperature is within specification.
8. Contact Mira Customer Service Team if none of the above resolved the issue.

4b - Product flowing water when switched off:

The digital mixing valve reduces the water flow slowly before final shut-off to reduce the severity of water hammer. The time duration depends on the flow rate and system pressures. This is normal and not a product fault.

Shower fittings can continue to drain down after the digital mixing valve is shut off, especially where there are large volumes of water present (e.g. large deluge heads or long pipe runs). This process can take several hours and may be triggered by changes in temperature or atmospheric pressure. This is normal and not a product fault. We would therefore recommend that all water outlets are kept contained within the water catchment area.

1. Check the issue is not a natural draining of the fittings. Remove the fittings and monitor the outlet if necessary.

2. Activate the shower a number of times at maximum flow to dislodge any debris.
3. If none of the above resolved the issue, isolate the water and power supply and contact Mira Customer Service Team.

4c - Showering temperature is hotter / colder than indicated or is fluctuating:

Note: The temperature displayed on the user controller is measured inside the digital mixing valve, not at the shower outlet.

The perceived temperature of the water from your shower can vary with shower fittings and room temperature. A wider, finer spray will cool more quickly and feel cooler than a direct spray, and long outlet pipe runs can also influence the blend temperature, in which case you may need to adjust the showering temperature.

1. **Combi Boiler fed products:** Check the hot water supply is hot enough when the shower is in use. Combi boilers are sometimes unable to maintain temperatures at higher flows or may cut-out at lower flows. Check no other devices are using hot water at the same time. Reduce or increase the outlet flow to around 8 litres per minute and see if that solves the issue. Tip: Use the Mira Showers app to check the temperature of the hot water inlet when the shower is running.
2. **Hot water storage tank fed products:** Check the hot water supply is not being depleted in use. Reduce the outlet flow or reduce showering time and see if that solves the issue. Tip: Use the Mira Showers app to check the temperature of the hot water inlet when the shower is running.
3. Check the hot and cold supplies are connected to the correct inlets, and that the temperature and pressures are within the product specification and are stable. Inlet water pressures must be nominally equal. **Note:** Use the Mira Showers app to check the temperature of the hot water inlet is within the temperature range of 55°C - 65°C.
4. Check no other devices are using water at the same time. Devices switching on/off (e.g. washing machines, taps etc.) can rapidly change the water pressure of the system causing rapid pressure and temperature changes.
5. Ensure Inlet filters and check valves, shower head and hose are not blocked (refer to "Cleaning and Maintenance Section").
6. If none of the above resolved the issue, and the measured temperature is significantly different to that on the controller display, contact Mira Customer Service Team.

4d - Shower turning off too soon:

1. Check to see if you have 'Warm Up' mode enabled. This is designed to 'pause' the shower once showering temperature is reached.
2. Check to see if you have a maximum showering duration set. This is designed to turn off the shower after a pre-determined duration.
3. Check to see if you are using pre-defined showering experiences. These may turn off the shower after a pre-determined duration.
4. The shower is designed to turn off after 30 minutes.
5. Use the Mira Showers app to check the error log. The shower is designed to turn off if the outlet temperature is too high.

6. Check inlet water temperature and pressures are within specification. The shower may turn off if these are out of specification. Tip: Use the Mira Showers app to check the temperature of the hot water inlet.
7. If none of the above resolved the issue, contact Mira Customer Service Team.

4e - Noise:

1. Pumped digital mixing valves can get air locked if not installed in accordance with the instructions in this guide and may exhibit outlet flow fluctuations and a high pitch “squealing” noise. Ensure the plumbing system eliminates air locking.
2. Some plumbing systems can produce “water hammer”. To reduce this effect, ensure all pipework is securely fixed.
3. The type of wall or flooring the appliance is fixed to will affect the perceived noise level from the product. For a quieter operation install the product to solid walls or structures.
4. If none of the above resolved the issue, contact Mira Customer Service Team.

Controller Faults

Display Message	Description	Action
UI is not connected to the valve. Please move UI within the range or pair with valve.	User controller cannot communicate with the valve.	Check valve is switched on. Move user controller closer to the valve. Re-pair with valve. If this persists, please consider purchasing Bluetooth Extension Adapter.
Valve error	Valve fault	Refer to 'Fault Diagnosis' section starting on page 59.
Valve reset	Valve fault has occurred that can be cleared by a reset.	Press the 'Reset' button or Refer to 'Fault Diagnosis' section starting on page 59.
Hot incoming water temperature too low	The hot water supply to the shower is too cold for proper control	Check the inlet isolators to the digital mixing valve are fully open. Use the Mira Showers app to check your hot water temperature is within specification.
Please try a different charger or cable	Faulty charging cable or charger not suitable for charging product	Try supplied cable. If fault persists call Customer Services. Important! Only USB C power + data cables and minimum of 5W power supply are compatible with the controller.
Error charging, please try again later. See user guide if problem persists.	An error has occurred during charging of the battery.	Disconnect the product from the charger and try again after 30 minutes. Try supplied cable only. If fault persists call Customer Services.
Battery too low to operate shower – please recharge	The battery has discharged too far for safe operation of the shower.	Charge the user controller.

Accessories

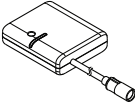
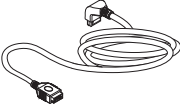
	Product	Product Code
	Mira Wireless Remote Accessory	2.1903.020
	Mira Bluetooth Extension Adapter	GP1502540W
	Wi-Fi Extension Cable	1335278

Cleaning and Maintenance

Always read the IMPORTANT SAFETY INFORMATION for your shower.

Cleaning the showerhead

Many household and commercial cleaners, including hand and surface cleaning wipes contain abrasives and chemical substances that can damage plastics, plating and printing and should not be used. These finishes should be cleaned with a mild washing up detergent or soap solution, and then wiped dry using a soft cloth.

De-scaling the showerhead and inspecting the hose

It is **IMPORTANT** to keep the showerhead and Hose clean and free from blockage to make sure your shower performs to its optimum. The showerhead **MUST** be regularly cleaned and the hose **MUST** be regularly inspected to ensure there is no internal collapse or blockage that could reduce the flow.

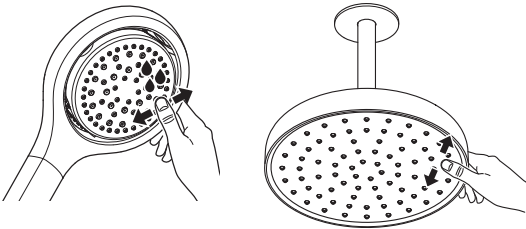

Use your thumb or a soft cloth to wipe any limescale from the soft nozzles.

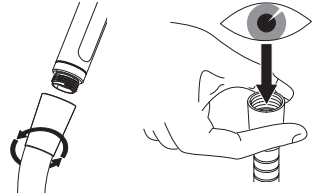

Unscrew the hose from the showerhead and the shower outlet.

Inspect the hose.

Warning! Failure to keep the showerhead nozzles clear or inspect the hose for blockage or internal/external collapse can restrict the flow rate from the shower. This may cause damage to the shower or result in the temperature delivered to the user rising to unsafe levels with a risk of scalding. You **MUST ALWAYS check the temperature before using the shower.**

Warning! Silk spray plate is susceptible to blockage in hardwater areas. If flow becomes restrictive, a removal tool 1479777 is available from Mira customer services to remove and clean the silk spray plate.

Replace/Clean the Check Valves/Filters

Read the section “Important Safety Information” first.

Before replacing any parts, ensure that the underlying cause of the malfunction has been identified. If the digital mixing valve is dismantled during installation or servicing then upon completion the product must be inspected to ensure there are no leaks.

Warning! There are no user serviceable components beneath the cover of the appliance. Only a competent tradesperson should remove the cover.

Check valve Cartridges and Filters - Removal and Installation

Hot water entering the cold supply, or vice versa, indicates that immediate attention is necessary. This is carried out by removing and cleaning, or renewing as necessary, the check valve cartridges.

Caution! Running your product without inlet filters can cause valve damage and will invalidate your product guarantee.

Isolate the water supplies and turn on an outlet for 5 seconds to release pressure within the valve. Isolate the electrical supply.

Loosen the screw and remove the cover from the digital mixing valve.

Carefully remove the clip and pull out the filter housing.

Remove the filter and rinse in clean warm water removing any dirt or debris. Replace if the filter mesh is damaged.

If the check valves need to be replaced, carefully remove them from inside the product and replace with new parts.

Refit the filter housing into digital mixing valve. Insert the clip to secure the filter housing.

Refit the supply pipes and restore water supply and electrical supply. Test shower and check for leaks.

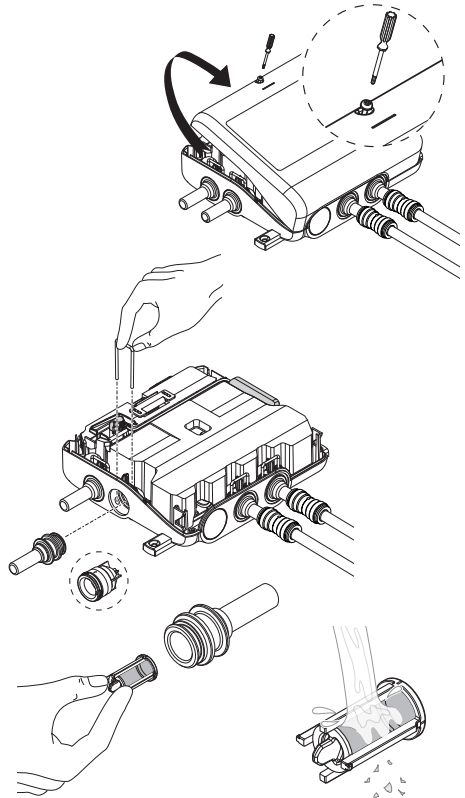

Disposal and Recycling

When this appliance has reached the end of its serviceable life it should be disposed of in a safe manner, in accordance with current local authority recycling or waste disposal policy. For more information about recycling, please contact your local council office.

Decommissioning and Recycling for WEEE



Electrical and electronic devices contain a range of materials that can be separated for recycling and used in new products. This product should not be disposed of with your general household waste. When this product has reached the end of its serviceable life, please take it to a recognised WEEE (Waste Electrical and Electronic Equipment) collection facility such as your local civic amenity site for recycling. Your local authority or retailer will be able to advise you of your nearest recycling facility.

For more information, visit <http://repic.co.uk/consumers/>

Frequency Bands and Maximum Radio

Frequency Power

Hereby, Kohler Mira Ltd. declares that the radio equipment type Mira Platinum is in compliance with EU Directive 2014/53/EU & UK S.I. 2017/1206. The full text of the EU & UKCA declaration of conformity is available at the following internet address:

www.mirashowers.co.uk

Technology	Frequency Band	Maximum Power
Bluetooth® Low Energy (Controller & Valve)	2402-2480MHz	< +4dBm
WLAN (802.11 b/g/n)	2400-2483.5MHz	< +18dBm
WLAN (802.11 a/n)	5150-5350MHz (indoor use only) / 5500-5725MHz	< +18.4dBm

Warning! Magnetic field is present on controller and controller cradle. It can be harmful to pacemaker wearers. Pacemaker wearers stay back 15cm.

The Product Security and Telecommunications Infrastructure (Security Requirements for Relevant Connectable Products) Regulations 2023

Hereby, Kohler Mira Ltd. declares that this radio equipment is in compliance with The Product Security and Telecommunications Infrastructure (Security Requirements for Relevant Connectable Products) Regulations 2023 (S.I. 2023/1007). The full Statement of Compliance and Vulnerability Disclosure Policy is available at the following internet address:

www.mirashowers.co.uk

Customer Service

Guarantee

Your product has the benefit of our manufacturer's guarantee which starts from the date of purchase. This guarantee only applies in the United Kingdom and Republic of Ireland.

Activating Your Guarantee

Registering your guarantee is quick and simple. To ensure your product is covered, please register online .



Scan the QR code to activate your guarantee now or call **0800 5978551** within 30 days of purchase (UK only).

What is Covered:

- The guarantee applies solely to the original installation under normal use.
- The product must be installed and maintained in accordance with the instructions given in this guide.
- Servicing must only be undertaken by us or our appointed representative.
- Repair under this guarantee does not extend the original expiry date. The guarantee on any replacement parts or product ends at the original expiry date.
- For shower fittings or consumable items we reserve the right to supply replacement parts only.

The guarantee does not cover:

- Call out charges for non product faults (such as damage or performance issues arising from incorrect installation, improper use, inappropriate cleaning, lack of maintenance, build up of limescale, frost damage, chemical attack, corrosion, system debris or blocked filters) or where no fault has been found with the product.
- Water or electrical supply, waste and isolation issues.
- Routine maintenance or replacement parts to comply with the requirements of Building / Plumbing / Electrical Standards or Schemes.
- Compensation for loss of use of the product or consequential or indirect loss of any kind.
- Damage or defects caused if the product is repaired or modified by persons not authorised by us or our appointed representative.
- Accidental or wilful damage.
- Products purchased ex-showroom display.
- Disinfection or descaling to reduce bacterial growth or contamination.

What to do if something goes wrong

If your product is not working correctly please refer to this manual or the Mira website for fault diagnosis and to check that it is installed and commissioned in accordance with our instructions. If this does not resolve the issue, our Customer Services team are here to help get you back up and running. To help us solve your problem quickly, please have your product name, power rating (if applicable) and date of purchase to hand.

Visit www.mirashowers.co.uk

Visit our website to register your guarantee, book a service visit, diagnose faults and purchase products.

Spares and Accessories

We stock a full range of spare parts and fittings and are all available to purchase either online or over the phone. Our online spare parts selector tool will help you quickly and easily identify the spare part for your product.

Visit www.mirashowers.co.uk/parts-accessories

Replacements and Repairs

In the unlikely event that your product needs a repair, our nationwide repairs and installation team are here to help. You can book a convenient date and time online.



Scan the QR code to book a service visit now or visit www.mirashowers.co.uk/support/repair-services/repair-service

We also offer a comprehensive replacement service for when your product needs a little refresh, visit our website or contact our team for more information on our replacement services.

Help us improve

Your experience is important to us and your review (whether good, bad or otherwise) will be posted on Trustpilot.com immediately to help other people make more informed decisions.

Visit uk.trustpilot.com/review/www.mirashowers.co.uk

Need to get in touch?

UK

T: 0800 001 4040
E: askus@mirashowers.com
www.mirashowers.co.uk

Eire

T: 01 531 9337
E: customerserviceire@mirashowers.com

Mira is a registered trade mark of Kohler Mira Limited.

The company reserves the right to alter product specifications without notice.

Registered Office:
Cromwell Road,
Cheltenham,
Gloucestershire
GL52 5EP

EU Importer address:
Kohler France S.A.S,
30 Boulevard de la Bastille,
75012 Paris,
France

