

## BEFORE YOU BEGIN

- All information is based on the latest product information available at the time of publication. Kohler China Ltd. reserves the right to make changes in product characteristics, packaging, or availability at any time without notice.
- These instructions contain important care, cleaning, and warranty information-**please leave these instructions for the consumer.**
- Make sure that the bath and the finished wall material are completely and correctly installed prior to installing your shower door. Prepare waterproof layer to wall and floor of the showering area. It is not allowed for any presence of electric switches and sockets. Make sure the floor drain runs smoothly.
- Before starting the door installation, lay out and identify all the parts. Use the exploded view illustrated on page 2 for reference.
- For the installation method of customized shower with different dimensions, please refer to this instructions.
- The product complies with QB 2584-2007.

**⚠ CAUTION: Risk of injury or product damage.**  
Tempered glass cannot be cut, drilled or knocked by hard object. Make sure corner area of the glass refraining from knocking so as to cause personal injury due to broken glass.

**ATTENTION:** Please install this door on Kohler receptors or curbs(Not included). If the curb is not Kohler-branded, please note its top width should be more than 80mm.

**IMPORTANT:** The shower door requires a flat vertical finished wall. The squareness of the wall is recommended no more than 3 mm/m. KOHLER Company won't take responsibility of the installation quality.

Do not use the enclosure for at least 24 hours.  
安装后 24 小时内请勿使用淋浴房。



## 安装之前

- 说明书中所有的资料是按最新出版的产品资料编写而成。科勒中国有限公司保留任何时候无须通知即可改变产品特性、包装或产品可供类型的权利。
- 说明书包括重要的安装、清洁及保养方面的内容, **请把这些资料交给用户阅读, 保管。**
- 确保在安装淋浴房之前已经完整正确地安装了浴室和完工墙面材料。淋浴区墙地面应做防水处理, 并不得布置有电器开关、插座。确保地面排水通畅。
- 在进行淋浴房安装之前, 请拿出、排列并确认所有的零部件。请参考第 2 页上所示的分解图。
- 对尺寸与本标准产品不同的定制淋浴房, 参照本说明书进行安装。
- 本产品符合 QB 2584-2007。

**⚠ 警告: 可能有人伤害或者产品损坏的危险。**  
钢化玻璃不能进行切割, 钻孔或硬物敲击。搬移或安装过程中, 小心确保玻璃边、角部位不受撞击, 以防爆裂伤人。

**建议:** 将本产品安装在科勒淋浴盆或挡水条上 (需另行购买)。如自备挡水条, 建议顶面宽度尺寸大于 80mm。

**重要事项:** 淋浴房需要安装在平坦垂直的墙面上。墙面的垂直度推荐在正负 3mm/m 以内。如果超出此范围, 科勒公司将不保证淋浴房的完美使用。

## ROUGHING-IN

## 尺寸图

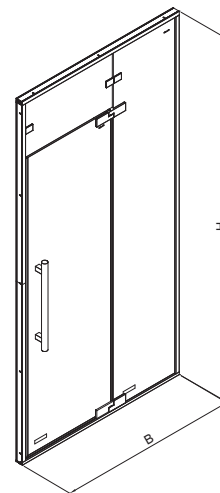

Unit: mm  
单位: 毫米

SKU	B	H
K-704600T	950-1600	2200-2600

ZHONGSHAN KOHLER SHOWER CO., LTD. NO13-1, XINGYE ROAD, ZHONGSHAN TORCH DEVELOPMENT ZONE, ZHONGSHAN, GUANGDONG, CHINA POST CODE: 528437  
中山科勒卫浴有限公司 广东省中山市中山火炬开发区兴业路 13-1 号 邮编: 528437

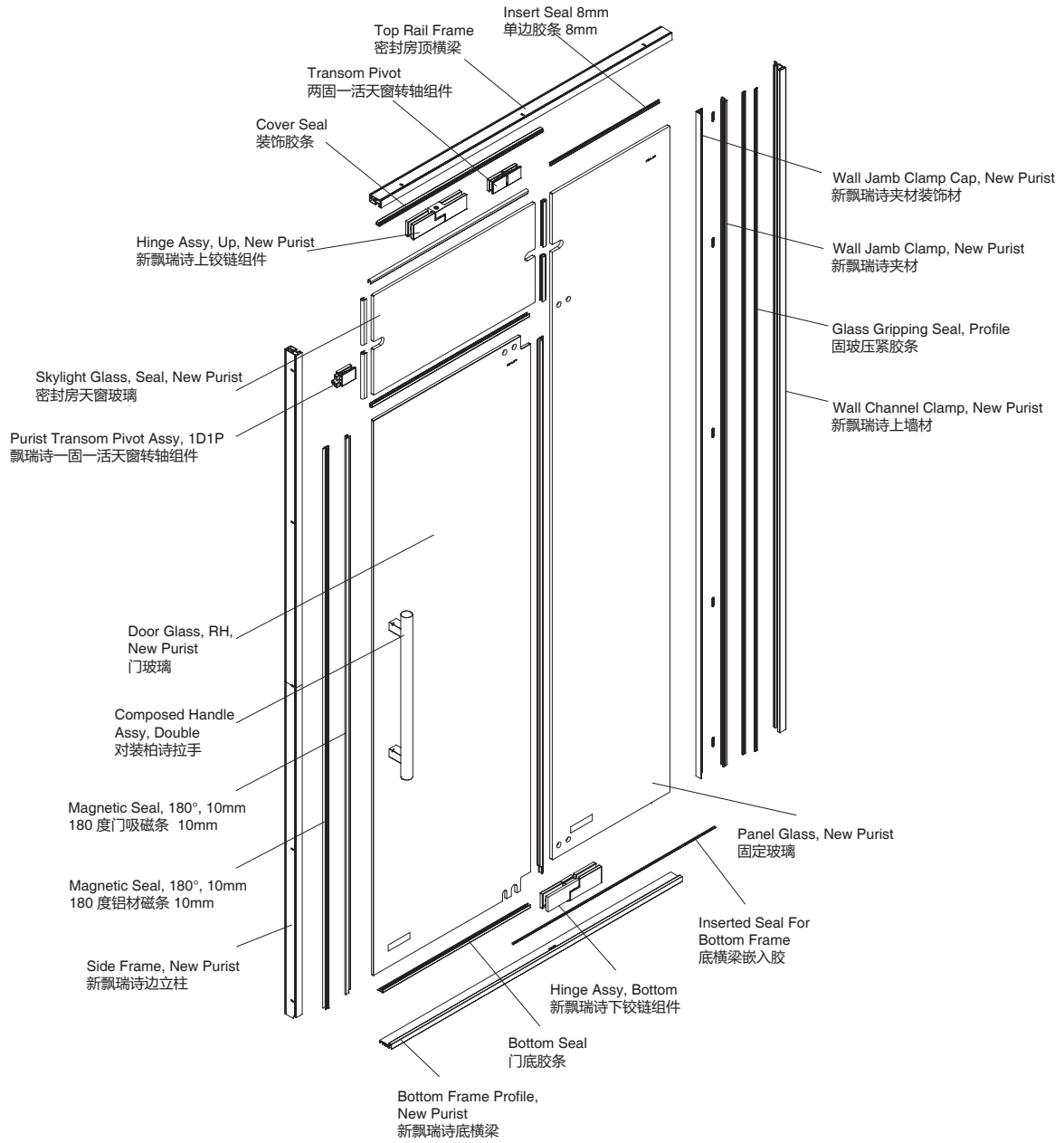

	X2	Side Frame, New Purist 新飘瑞诗边立柱
	X1	Wall Jamb Clamp Cap, New Purist 新飘瑞诗夹材装饰材
	X1	Wall Jamb Clamp, New Purist 新飘瑞诗夹材
	X1	Wall Channel Clamp, New Purist 新飘瑞诗上墙材
	X1	Bottom Frame Profile, New Purist 新飘瑞诗底横梁
	X1	Insert Magnetic Seal, 10mm, Skyline 铝材磁条 10mm
	X1	Magnetic Seal, 180°, 10mm 180度门吸磁条 10mm
	X1	Side Seal, 10mm, Profile, Hinged Door 侧边胶条 10mm
	X1	Bottom Seal For Purist DR Glass Profile 门底胶条
	X2	Glass Gripping Seal, Profile, 10mm 固玻压紧胶条 10mm
	X1	Inserted Seal For Bottom Frame, Purist 底横梁嵌入胶
	X1	Insert Seal 单边胶条

	X1	Wall Side Seal, 10mm, Profile 泡泡胶条 10mm
	X1	Cover Seal 装饰胶条
	X1	Composed Handle Assy 450mm, Double 对装柏诗拉手 450mm
	X1	Purist Transom Pivot Assy, 1D1P 飘瑞诗一固一活天窗转轴组件
	X1	Purist Transom Pivot Assy, 1D2P 飘瑞诗两固一活天窗转轴组件
	X1	Hinge Assy, Up, New Purist 新飘瑞诗上铰链组件
	X1	Hinge Assy, Bottom, New Purist 新飘瑞诗下铰链组件
	X5	Connector Block 塑料压块
	X5	CSK Screw ST3.5X6 沉头平尾螺丝 ST3.5X6
	X10	Pan Screw ST3.5X40 圆头螺丝 ST3.5X40
	X10	Hollow Wall Anchor, Nylon 膨胀套

**Tools Required/所需工具**

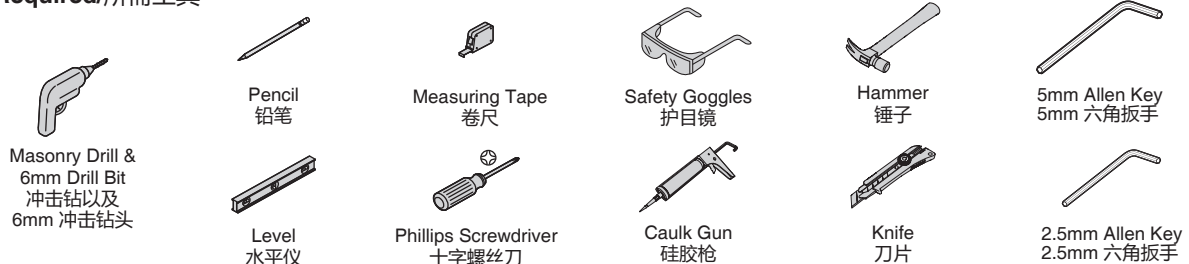

Place the weather bar. The installation surface in the bathroom must be flat.  
放置挡水条，淋浴房安装面必须打水平。

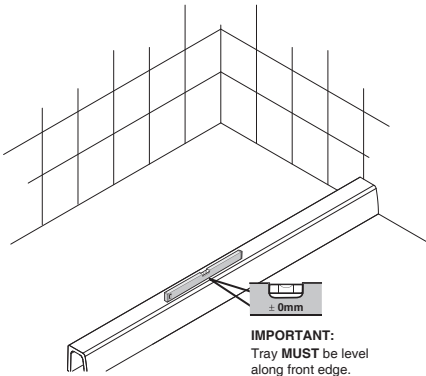

**IMPORTANT:** Tray **MUST** be level along front edge.  
**重要:** 底盘必须水平。

**STEP 1**

Install the bottom frame (20 mm to the edge from the inside). Fix the wall channels at both ends and make sure that the channels are aligned to the bottom frame.  
安装底横梁（内偏20mm安装），固定两端上墙铝材，请确保上墙铝材固定时与底横梁对齐。

**IMPORTANT:** Make sure the seals are pre-installed on the wall channels.  
**重要:** 安装前确保铝材有预装好胶条。

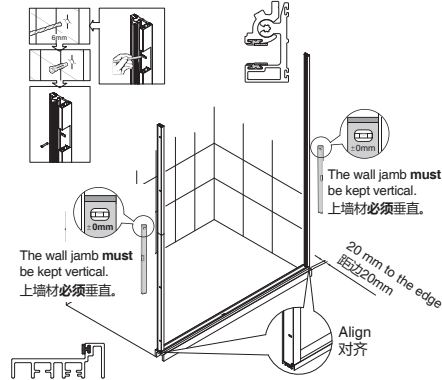

The wall jamb must be kept vertical.  
上墙材必须垂直。

The wall jamb must be kept vertical.  
上墙材必须垂直。

±0mm

20 mm to the edge  
距20mm

Align  
对齐

**STEP 2**

Make sure the ceiling is firm enough and then fix the top frame onto the ceiling.  
将顶横梁固定到天花板上，之前请确定天花板是足够的牢固。

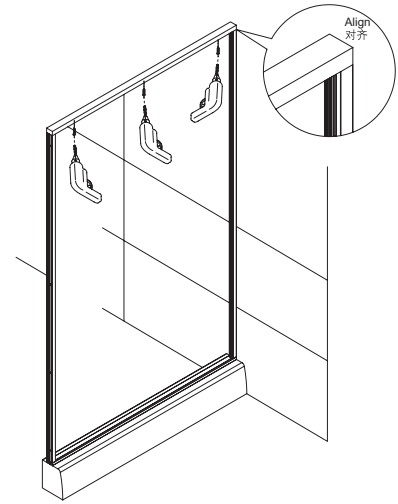

**STEP 3**

Insert the hingelite panel into the wall channel.  
将铰链固定玻璃插入上墙铝材内。

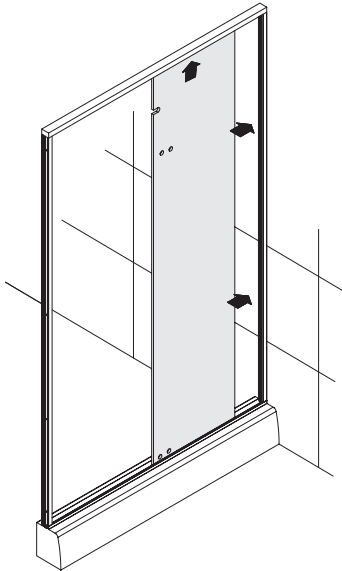

**STEP 4**

Install the bottom hinges onto the glass panels. Adjust the distance between the panel glass and the wall channels to about 680 mm.  
安装下铰链到固玻，之后调节固玻到铝材尺寸，约为680mm。

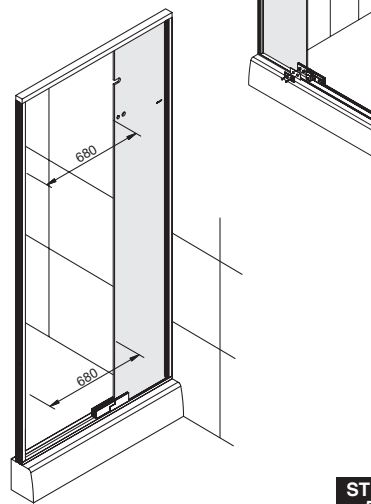

**STEP 5**

Tighten the screws of the wall channels and clamp the side panels.  
锁紧墙材的螺丝，将固定玻璃夹紧。

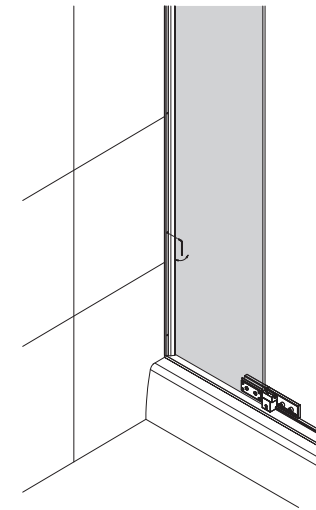

**STEP 6**

Fix the upper hinge onto the door glass.  
将上铰链固定到门玻璃上。

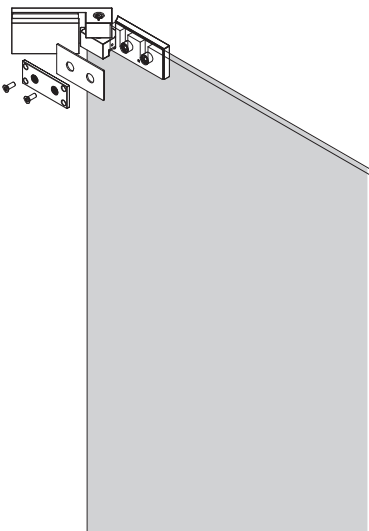

**STEP 7**

Lift the door glass and insert into the bottom hinge.  
将门玻璃抬起，插入下铰链里。

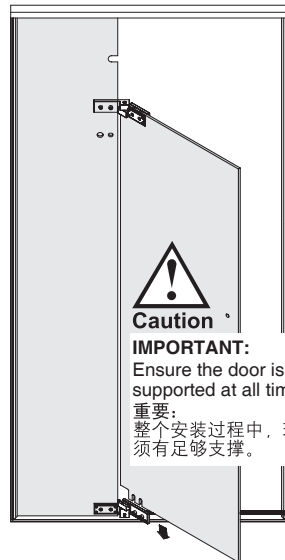

**Caution**

**IMPORTANT:** Ensure the door is fully supported at all times.

**重要:** 整个安装过程中，玻璃门必须有足够支撑。

**STEP 8**

**IMPORTANT:** When the door glass is closed, first tightened the backboard of upper hinge, then tightened the backboard of bottom hinge.  
**重要:** 门玻处于闭合状态时，先锁紧上铰链背板，之后锁紧下铰链背板。



The backboard may be tightened only when the door glass is closed.  
必须是闭合状态下再锁紧背板。

**STEP 9**

Fix the transom assembly to the side panel and wall channel. Do not tighten the screws.  
将天窗转轴组件固定到固定玻璃（不需要锁紧螺丝）及铝材上。

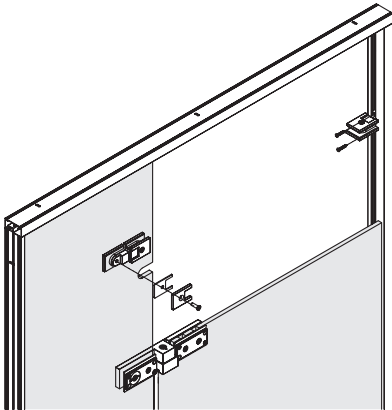

STEP 10

Fix the transom to the assembly, adjust the gaps on each side and then tighten the screws.  
将天窗固定到转轴上,调节好各边间隙,锁紧螺丝。

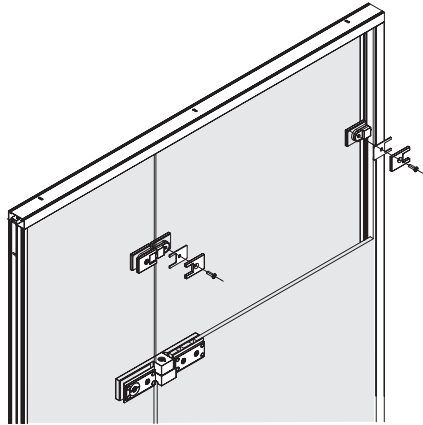

STEP 11

Fix decorative cover of the transom assembly.  
安装天窗转轴装饰盖。

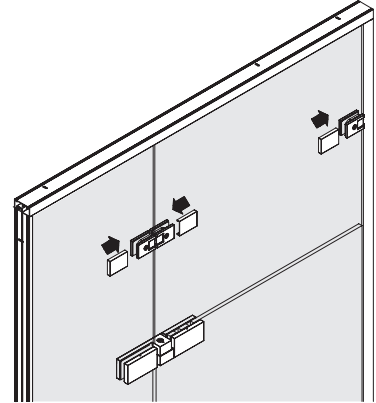

STEP 12

Insert side seal between side panel and top frame.  
固定玻璃与上横梁间卡入单边胶条。

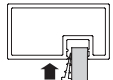

Insert decorative seal into top frame.  
将装饰胶条卡入上横梁。

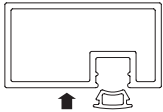

Insert wall side seal, make sure seals match length dimension, total six seals.  
插入泡密封胶条,注意对应长度尺寸,共计6条。

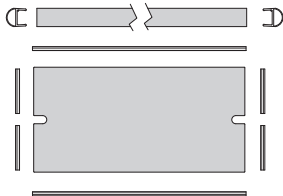

STEP 13

Install the magnetic strip and the side and bottom waterproof seals.  
安装磁条、侧边防水胶条和底边防水胶条。

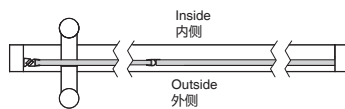

The side and the bottom waterproof seals shall respectively extend to the top and the bottom of the hinge.  
侧边防水胶条需要通到铰链顶部,底部防水胶条需要通到铰链底部。

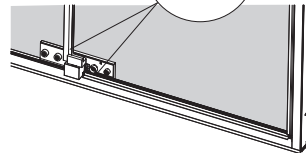
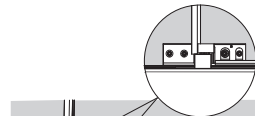

STEP 14

Install the decorative frame, then install handle.  
扣上铝材装饰盖材,再安装拉手。

Install the decorative frame.  
扣上铝材装饰盖材。

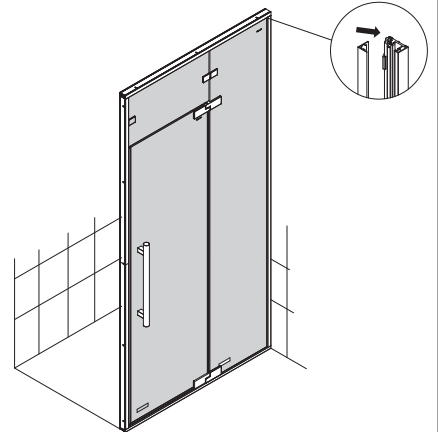

STEP 15

Apply the silicone sealant.  
打防水胶。

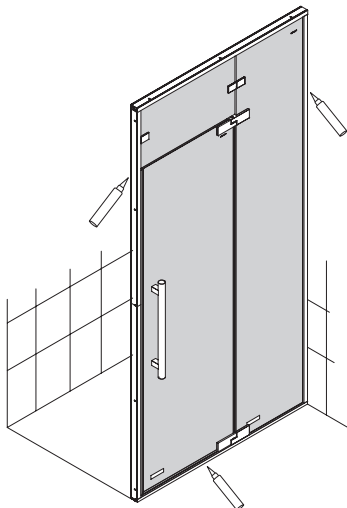

STEP 16