

安装说明

感应龙头

记录您的型号：

Record your model number: _____

English, page 18

KOHLER®

1596723-T2-C

感谢您选择科勒

需要帮助？请联系我们的客户服务中心。

- 中国大陆：+(86) 800-820-2628, +(86) 400-820-2628
- 保养和清洁：kohler.com.cn/support/care-and-cleaning/

工具与材料

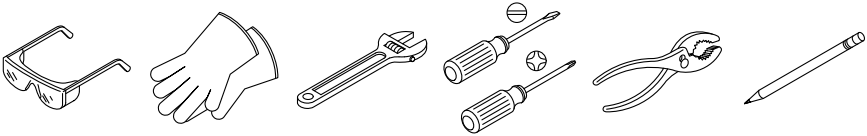

32 mm - 38 mm 孔钻头 G1/2 供水阀

开始之前



警告： 使用电气产品时，务必始终遵守基本注意事项，包括：



危险： 存在触电风险。仅连接到受漏电保护器 (RCD) 保护的电路。



警告： 存在触电风险。需要接地。所有电气连接均应由资质合格的电工操作。



警告： 存在触电风险。维修前先断开电源。



警告： 存在人身伤害或财产损失的风险。开始安装前先仔细阅读说明。



小心： 存在淡水污染风险。此水龙头包含反虹吸保护。为防止水污染，请勿移除任何内部组件。



小心： 产品存在受损风险。本产品包含敏感的电子元件。请勿将装有化学品或清洁产品的敞口容器存放在本产品附近。清洁抹布或海绵在存放前必须用清水冲洗干净。

重要信息! 请勿使用开关控制的电源插座（通常用于垃圾处理）为水龙头供电。

注： 本产品所需的电源需要使用特定连接头连接到阀盒。购买科勒交流、直流或混合型选件。还提供多交流适配器。如需更多信息，请参阅 kohler.com.cn 上的产品规格表。

注： 此水龙头设计用于科勒 40419T-NA AC/DC 变压器或科勒 26844T-NA 电池盒。单独购买。

请遵守当地管道安装、建筑及电气条例。

如果安装可选的交流/直流变压器，请在附近准备一个非开关 220 V 电源插座。

关闭供水系统。

这款水龙头适用于单孔台盆。

对于新安装，请在安装水槽之前安装水龙头和排水管。

对于不均匀的安装表面（如瓷砖灌浆缝），在水龙头下方涂抹合适的密封硅胶。**请勿使用石油基密封硅胶。**

本指南中显示的水龙头可能与您的实际产品不同。但安装步骤仍然适用。

如需与混水阀一起安装，需要两根 G1/2 压缩供水软管。

1. 安装水龙头

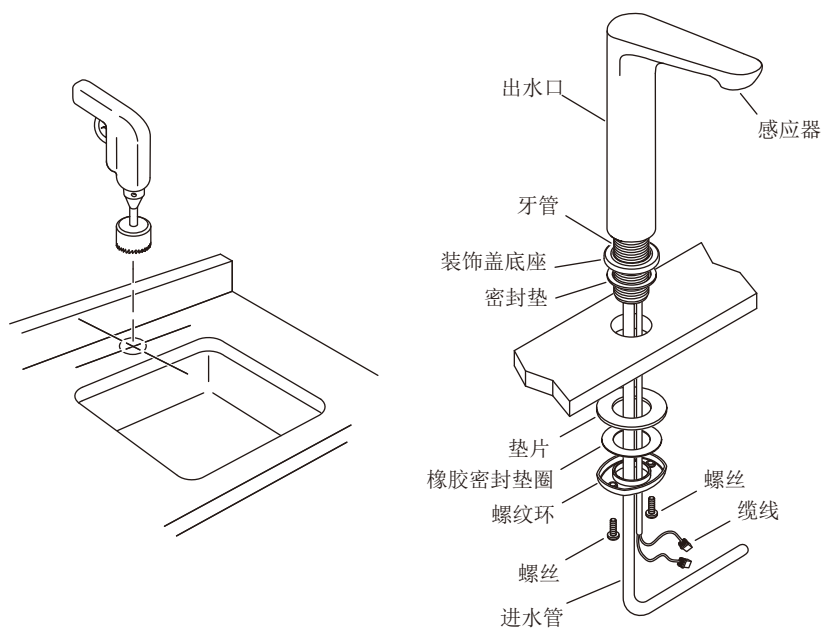

注： 在钻安装孔之前，请使用以下尺寸确保放置正确：

尺寸要求

- 安装孔：** 最小直径为 1-1/4 英寸（32 毫米）至最大直径为 1-1/2 英寸（38 毫米）。
- 出水口到墙壁：** 出水口背面与墙壁之间的最小距离为 1-3/4 英寸（44 毫米）。
- 出水口到水槽：** 出水口底座与水槽台下盆之间的最大距离为 1-1/8 英寸（29 毫米）。

安装水龙头

- 确定安装孔的位置。
- 根据台面制造商的说明，在安装表面钻一个孔。
- 将密封垫安装到装饰盖底座的凹槽中。
- 将水龙头、进水管和缆线穿过安装孔。
- 将螺钉部分拧入螺纹环，直至螺钉从另一侧伸出 1/4"（6 mm）。

- 从水槽下方，将垫片、橡胶密封垫圈和螺纹环安装到出水口。
- 前后定位螺钉，拧紧螺丝。

2. 安装控制盒

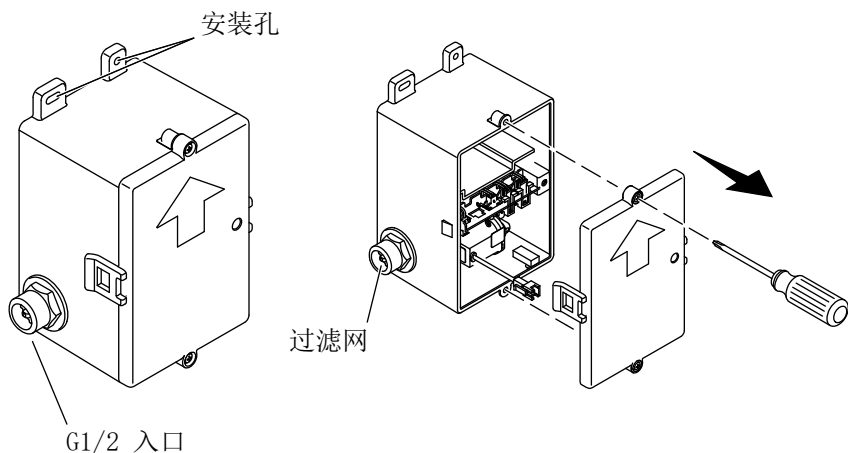

注： 在将控制盒安装到墙壁上之前，请确认软管能够连接到供水阀和控制盒入口。

注： 请参阅规格表，以确定控制盒的安装位置。

- 将控制盒置于台面下方并标记安装孔的位置。
- 确认传感器线缆位于台面下方。
- 钻出 1/4" (6 mm) 的定位孔。
- 根据您的墙壁材料使用标准膨胀胶粒（随附）。
- 箭头朝上将控制盒固定在墙上。用两颗螺丝（随附）固定。
- 拧下控制盒螺丝以拆下盖板。

3. 连接控制盒

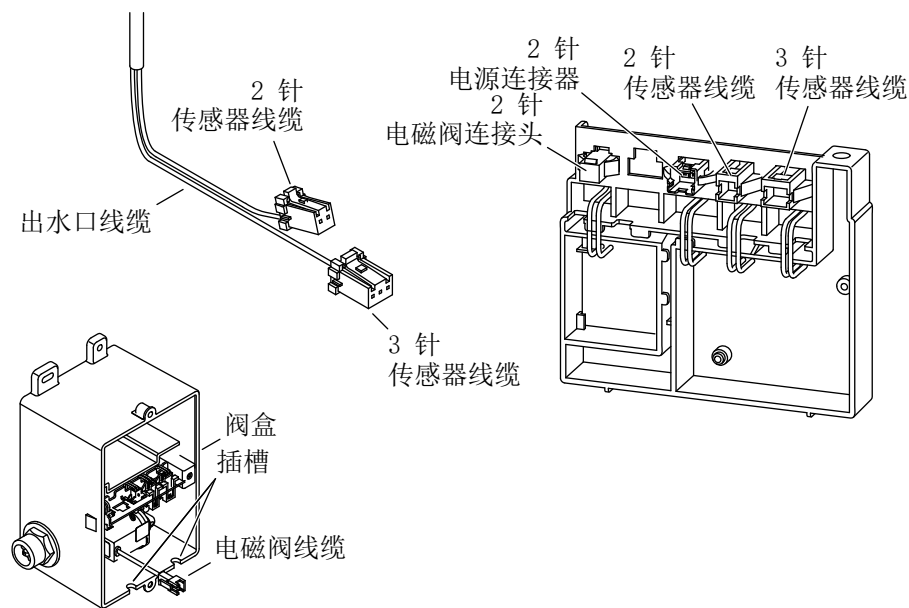

重要信息! 控制盒和盖板上放置传感器电缆的插槽。安装盖板时，小心不要挤压传感器线缆。

- 将阀盖上的 3 针传感器线缆连接到出水嘴上的 3 针传感器线缆（红色、白色和绿色线缆）。
- 将阀盖上的 2 针传感器线缆连接到出水嘴上的 2 针传感器线缆（橙色和黑色线缆）。
- 将传感器线缆穿过控制盒中的插槽。
- 将盖板固定在控制盒上，但不要拧紧，以便于后续操作。

4. 连接供水系统

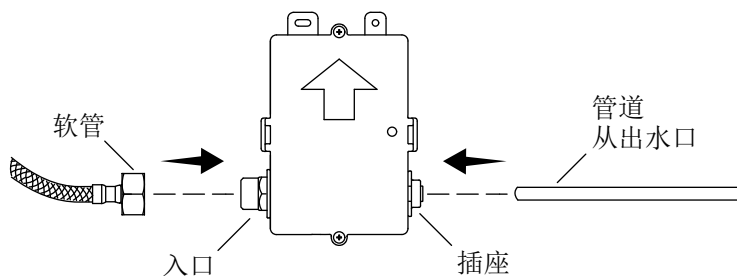
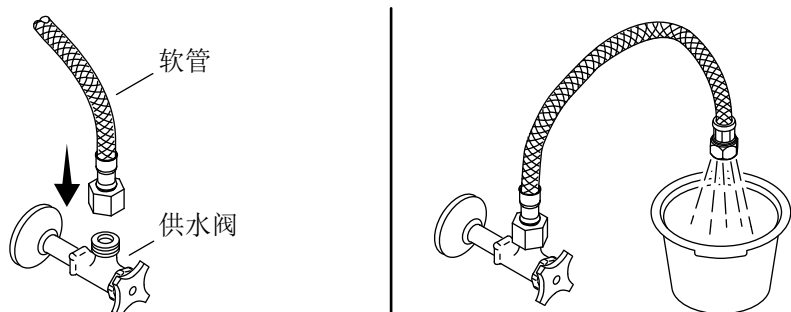

进水连接

- 将软管连接到供水阀。
- 将一个水桶放在供水阀下方并打开供水系统。
- 慢慢打开供水阀将杂质冲掉。
- 关上供水阀。
- 将随附的软管从供水阀连接到控制盒。

出水连接

- 确认出水嘴软管的长度能够达到控制盒。必要时剪切软管。去除任何毛刺和尖锐边缘。
- 将软管插入配件（控制盒出水端），直到无法再插入。
- 确认软管牢固。

5. 安装混合阀（可选）

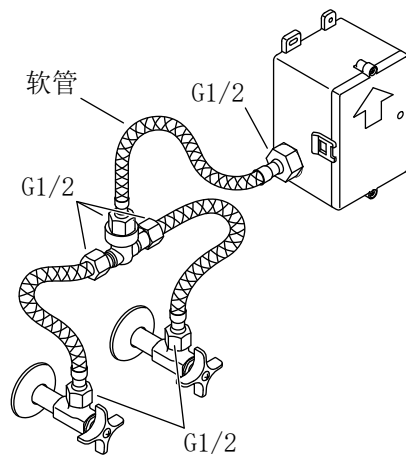

- 将混合阀连接到阀箱上的入水口。
- 将软管从混合阀连接到供水阀。

6. 安装交流单电源（可选）

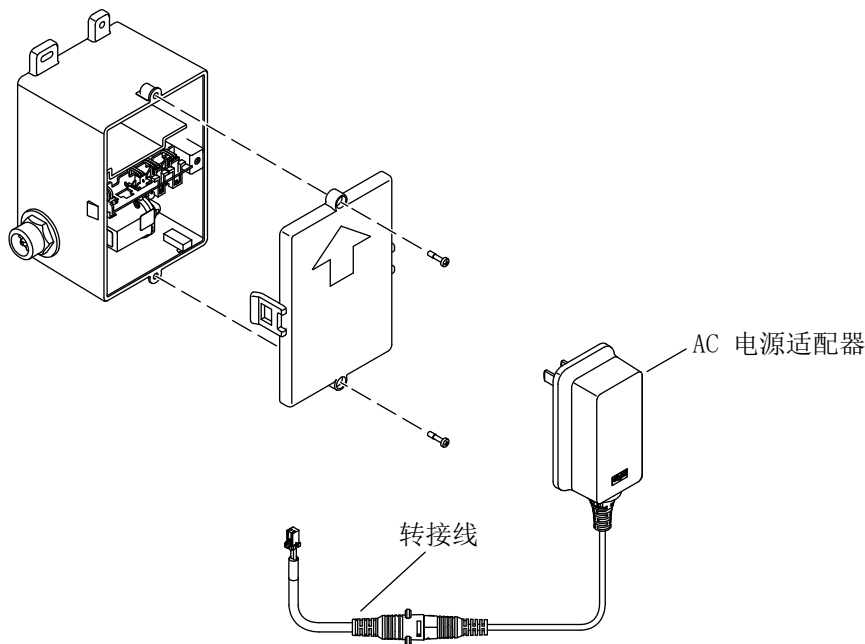

重要信息! 请勿使用开关控制的电源插座（通常用于垃圾处理）为水龙头供电。

重要信息! 安装盖子时，小心不要挤压管线。

重要信息! 在 15 秒的学习周期内，确保传感器前面的区域内没有物体，否则水龙头可能无法正常工作。

注意： 选择 AC 电源适配器组件的位置时，确认适配器线能够到达阀盒上的电源线。安装时请确认 AC 电源适配器和转接线连接稳固。

注： 当水龙头最初连接到电源时，LED 将闪烁，指示传感器检测范围正在自动调整。

- 安装恒定的非开关 220 V 电源。
- 将 AC 电源适配器组件（单独出售）安装在阀盒可触及的范围内。
- 拧下控制盒螺丝以拆下控制盒盖板。
- 将 AC 电源适配器组件的 2 针电源线连接到控制盒中的 2 针电源连接头。
- 将 AC 电源适配器组件连接到电源。

- 将多余的线缆固定在台面下方。
- 将控制盒盖板固定到控制盒上。
- 等待 15 秒，让传感器在自动感应距离之间循环。

7. 安装直流电源盒（可选）

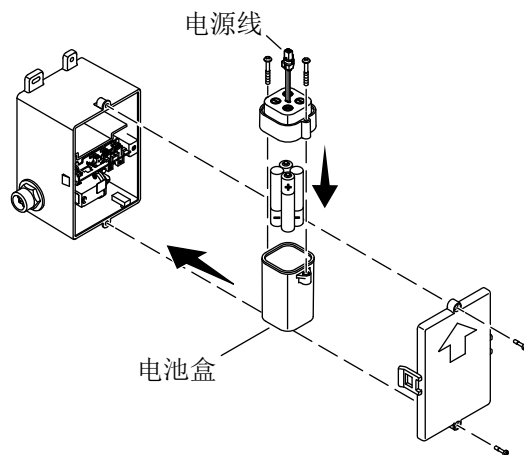

重要信息! 如果电池耗尽，请更换电池盒和电池。

重要信息! 安装盖子时，小心不要挤压管线。

重要信息! 在 15 秒的学习周期内，确保传感器前面的区域内没有物体，否则水龙头可能无法正常工作。

注: 请勿混用新旧电池。

- 拧下控制盒螺丝以拆下控制盒盖板。
- 拧下电池盒上的螺丝，取下电池盒盖板。
- 插入四节 AA 电池 (LR06)（随附）。有关电池方向，请查看电池盖板。
- 重新安装电池盒盖板，并用螺丝固定。
- 连接电源线。
- 将电池盒放入控制盒内的空位中。
- 将控制盒盖板固定到控制盒上。
- 等待 15 秒，让传感器在自动感应距离之间循环。

LED 指示灯

注: 当水龙头最初连接到电源时，LED 将闪烁，指示传感器检测范围正在自动调整。在传感器自动调整的约 15 秒内，请勿将任何物体放在传感器前面。

注：当直流电池电量不足时，控制阀组件盖板上的 LED 将每 6 秒闪烁一次红光。

□ 当直流电池耗尽时，LED 将每 2 秒闪烁一次。更换电池。

8. 安装落水器

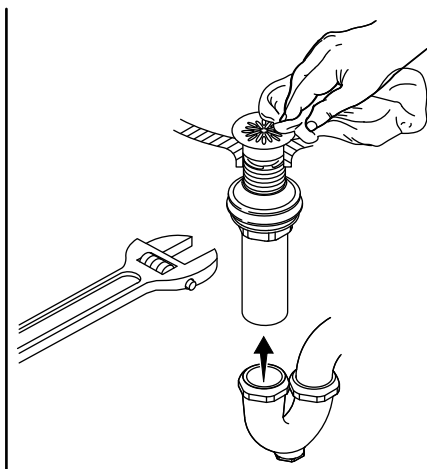
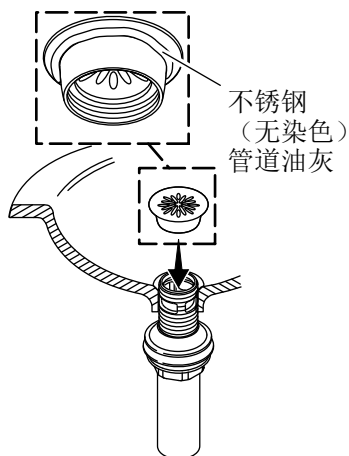

- 拆卸排水管。
- 在法兰底部涂上管道油灰并安装。
- 将螺纹密封胶带粘贴到排水管螺纹上。拧紧螺母。
- 连接排污通道。擦掉多余的管道油灰。

9. 完成安装

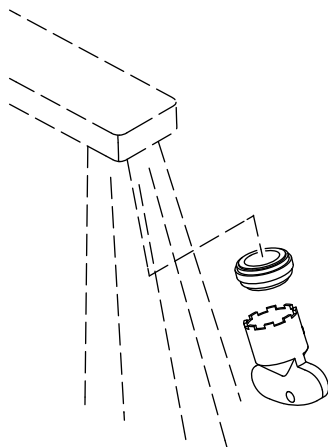

注： 连接完成后 15 秒内避开传感器前面的区域。如果在前 15 秒内激活传感器，则传感器将无法正常工作。断开并重新连接电源以重置传感器。

- 如果适用，请打开排水管。
- 暂时盖住水龙头上的传感器或关闭供水系统。
- 露出水龙头上的传感器或打开供水系统。
- 打开水龙头并检查所有连接是否漏水。酌情调整。
- 使用随附的钥匙拆下起泡器。
- 让水流出出水口 1 分钟。检查漏水情况，并酌情调整。
- 使用随附的钥匙重新安装起泡器。

故障排除

本故障排除指南仅供一般辅助之用。有关服务和安装问题或疑虑，请致电 400-820-2628。

故障表现	可能原因	建议措施
1. 无水流。	<ul style="list-style-type: none">A. 供水阀关闭。B. 无电源或连接错误。C. 感应范围内有物体。D. 传感器镜头脏污。E. 滤网堵塞。	<ul style="list-style-type: none">A. 打开供水阀。B. 检查电源和连接。C. 移除物体。D. 用湿软布擦拭传感器镜头。用柔软的干布擦干。E. 拆下并清洁滤网。
2. 流量低。	<ul style="list-style-type: none">A. 供水压力低。B. 起泡器堵塞。C. 滤网堵塞。	<ul style="list-style-type: none">A. 检查进水压力。压力应至少为 20 psi (137 kPa)。B. 拆下并清洁起泡器。如需清除钙/矿物质沉积物，请将起泡器塑料插件浸泡在醋和水比例为 50:50 的混合液中。仅浸泡插件，切勿浸泡其他零部件。C. 拆下并清洁滤网。
3. 水流恒定不变。	<ul style="list-style-type: none">A. 电磁阀不工作。	<ul style="list-style-type: none">A. 订购并安装新的电磁阀组件。
4. 水龙头持续滴水。	<ul style="list-style-type: none">A. 电磁阀膜片损坏。	<ul style="list-style-type: none">A. 订购并安装新的电磁阀膜片。
5. 间歇性激活。	<ul style="list-style-type: none">A. 水龙头与台面的角度不正确或使用区域未对准。B. 线缆被挤压或损坏。	<ul style="list-style-type: none">A. 确认水龙头已按照安装说明安装。确认水龙头安装在水槽边缘上方的位置。B. 拆下出水嘴，并在重新组装之前检查线缆是否已塞入出水嘴内。
6. 传感器大约每 2 秒闪烁一次。	<ul style="list-style-type: none">A. 交流电源未正确安装。B. 电池无电。	<ul style="list-style-type: none">A. 重新连接交流变压器。B. 更换电池。

Installation Instructions

Sensor Faucets

Thank You for Choosing KOHLER

Need help? Please contact our Customer Care Center.

- Mainland China: +(86) 800-820-2628, +(86) 400-820-2628
- Care and cleaning: kohler.com.cn/support/care-and-cleaning/

Tools and Materials

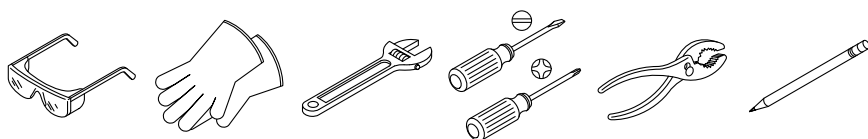



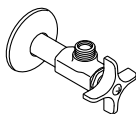



Plumbers Putty Sealant Tape 6 mm Drill Bit



32 mm - 38 mm Hole Bit G1/2 Supply Stop

Before You Begin

-  **WARNING: When using electrical products, basic precautions should always be followed, including the following:**
-  **DANGER: Risk of electric shock.** Connect only to a circuit protected by a Residual Current Device (RCD).
-  **WARNING: Risk of electric shock.** Grounding is required. A qualified electrician must route all electrical wiring for the product.
-  **WARNING: Risk of electric shock.** Disconnect the power before servicing.
-  **WARNING: Risk of injury or property damage.** Read all instructions thoroughly before beginning installation.
-  **CAUTION: Risk of fresh water contamination.** This faucet contains back-siphonage protection. To prevent water contamination, do not remove any internal components.
-  **CAUTION: Risk of product damage.** This product contains sensitive electronic components. Do not store open containers of chemical or cleaning products near this product. Cleaning rags or sponges must be rinsed with fresh water before storage.

IMPORTANT! Do not use a switch-controlled electrical outlet (typically used for garbage disposals) to provide power to the faucet.

NOTE: This product requires a power supply that uses a specific connector to the valve box. Purchase a KOHLER AC, DC, or hybrid option. A multi-AC adapter is also available. Refer to the product specification sheet found on kohler.com.cn for more information.

NOTE: This faucet is designed for use with Kohler 40419T-NA AC/DC transformer or Kohler 26844T-NA battery pack. Purchase separately.

Follow all local plumbing, building, and electrical codes.

If installing the optional AC/DC transformer, provide an unswitched 220 V electrical source within reach.

Turn OFF the water supplies.

This faucet is for a single-hole bathroom sink.

For new installations, install the faucet and drain to the sink before installing the sink.

For uneven mounting surfaces (such as tile grout lines), apply a suitable sealant under the faucet. **Do not use petroleum-based sealant.**

The faucet shown in this Installation Instructions may differ from your actual product. The installation steps still apply.

For installation with a mixing valve, two G1/2 compression supply hoses are required.

1. Installing the Faucet

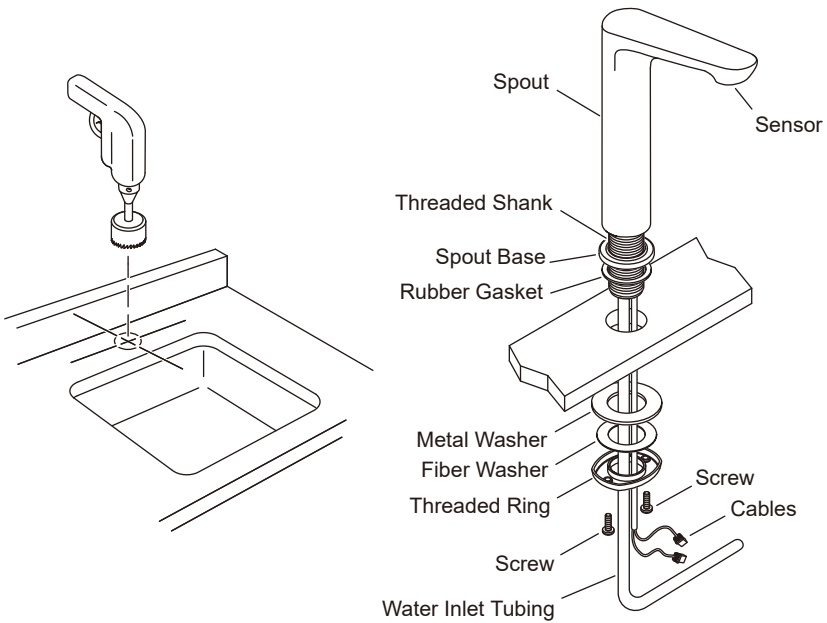

NOTE: Before drilling the installation holes, please verify proper placement by using the following dimensions:

Dimensional Requirements

- Mounting Hole:** 1-1/4" (32 mm) minimum to 1-1/2" (38 mm) maximum diameter.
- Spout to Wall:** 1-3/4" (44 mm) minimum distance between the back of the spout and the wall.
- Spout to Sink:** 1-1/8" (29 mm) maximum distance between the spout base and the edge of the sink bowl.

Install the Faucet

- Determine the mounting-hole location.
- Drill a hole through the mounting surface according to the surface manufacturer's instructions.
- Install the spout base and rubber gasket onto the spout threaded shank.

- Insert the faucet, water inlet tubing, and cables through the mounting hole.
- Partially thread the screws into the threaded ring until they extend 1/4" (6 mm) out the opposite side.
- From under the sink, install the metal washer, fiber washer, and threaded ring onto the spout.
- Position the screws to the front and back. Tighten the screws.

2. Install the Control Box

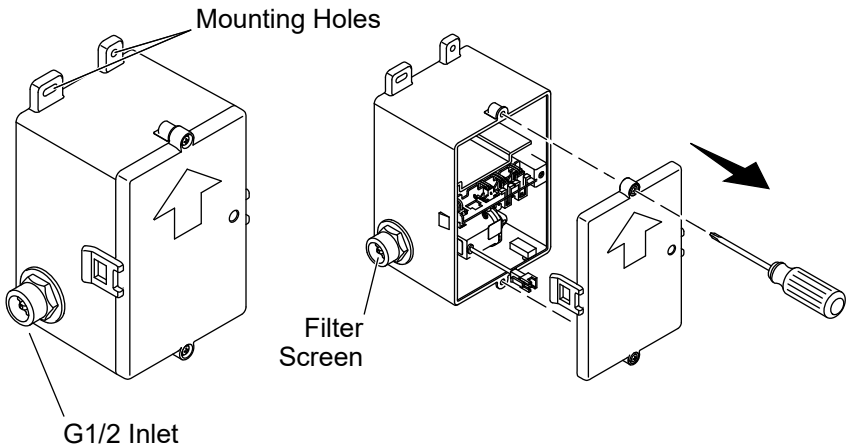

NOTE: Verify that the flex hose can be connected to the supply stop and the control box inlet before installing the control box to the wall.

NOTE: Refer to the Rough-in to determine the control box installation location.

- Position the control box below the deck and mark the locations for the mounting holes.
- Verify that the sensor cable is below the countertop.
- Drill 1/4" (6 mm) pilot holes.
- Use the standard wall anchors (provided) depending on your wall material.
- Attach the control box to the wall with the arrow pointing upward. Secure with the two provided screws.
- Unthread the control box screws to remove the cover.

3. Connect the Control Box

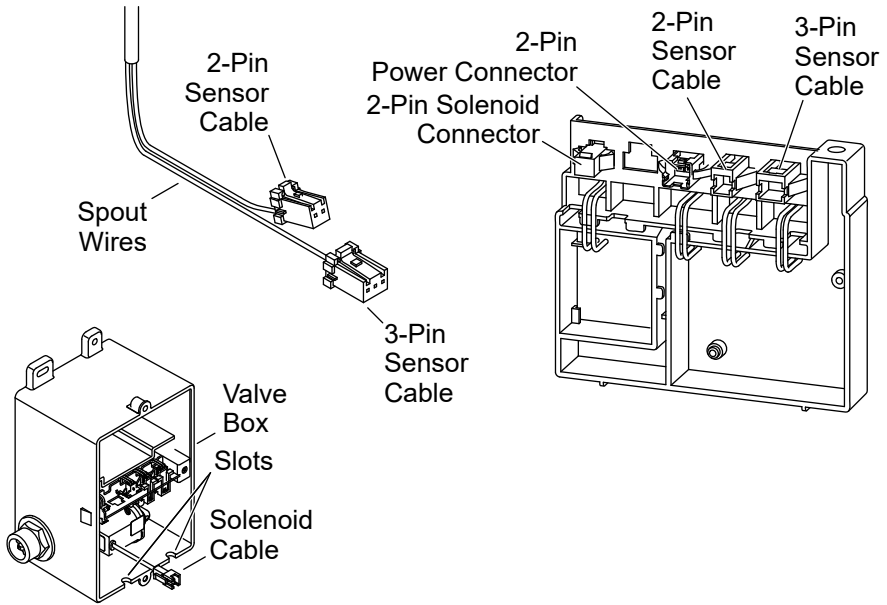

IMPORTANT! The control box and cover have slots for the sensor cables. Use care not to pinch the sensor cables when installing the cover.

- Connect the 3-pin sensor cable from the valve cover to the 3-pin sensor cable from the spout (red, white, and green cables).
- Connect the 2-pin sensor cable from the valve cover to the 2-pin sensor cable from the spout (orange and black cables).
- Guide the sensor cables through the slots in the control box.
- Loosely secure the cover to the control box for future access.

4. Connect the Supplies

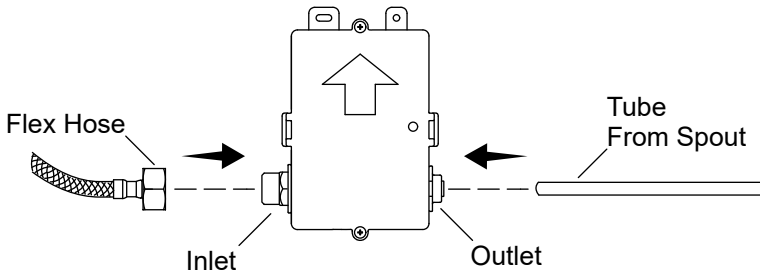
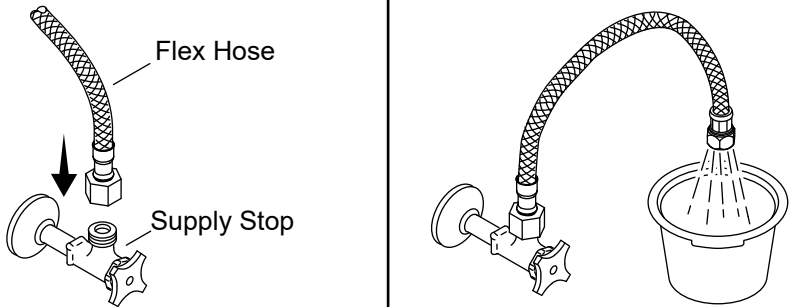

Inlet Connections

- Connect the flex hose to the supply stop.
- Place a bucket under the supply stop and turn ON the water supply.
- Slowly open the supply stop to flush debris.
- Turn OFF the water.
- Connect the provided flex hose from the supply stop to the control box.

Outlet Connections

- Verify that the tube from the spout is the appropriate length to reach the control box. Cut the tube if necessary. Remove any burrs and sharp edges.
- Insert the tube into the fitting (control box outlet end) until the tube stops.
- Verify that the tube is secure.

5. Install the Mixing Valve (Optional)

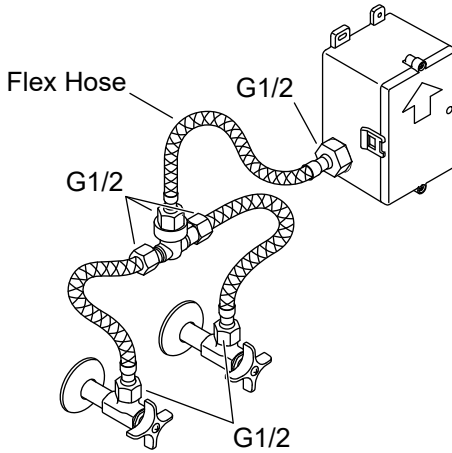

- Connect the mixing valve to the inlet on the valve box.
- Connect the hoses from the mixing valve to the supply stops.

6. Install the AC Single Supply (Optional)

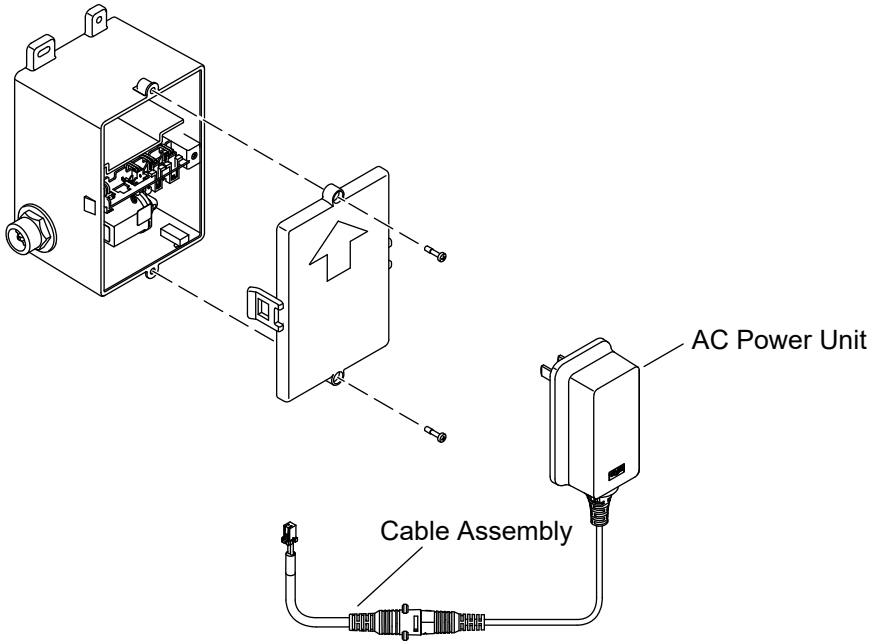

IMPORTANT! Do not use a switch-controlled electrical outlet (typically used for garbage disposals) to provide power to the faucet.

IMPORTANT! Use care not to pinch the tube or cables when installing the cover.

IMPORTANT! The area in front of the sensor must be free of objects during the 15 seconds learning cycle or the faucet may not function properly.

NOTICE: When selecting a location for the AC power unit assembly, verify that the power unit cord will reach the power cord on the valve box. Confirm that the AC power unit and the cable assembly is firmly connected.

NOTE: When the faucet is initially connected to a power source, the LED will flash to indicate that the sensor detection range is automatically adjusting.

- Install a constant unswitched 220 V electrical source.
- Install the AC power unit assembly (sold separately) within reach of the valve box.

- Unthread the control box screws to remove the control box cover.
- Connect the 2-pin power cable from the AC power unit assembly to the 2-pin power connector in the control box.
- Connect the AC power unit assembly to the electrical supply.
- Secure any excess wire under the deck.
- Secure the control box cover to the control box.
- Allow 15 seconds for the sensor to cycle through the automatic sensing distance.

7. Install DC Power Unit (Optional)

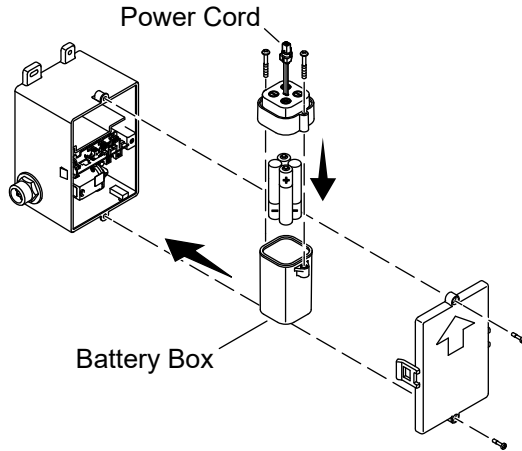

IMPORTANT! In the event of exhausted batteries, replace the battery box and batteries.

IMPORTANT! Use care not to pinch the tube or cables when installing the cover.

IMPORTANT! The area in front of the sensor must be free of objects during the 15 seconds learning cycle or the faucet may not function properly.

NOTE: Do not mix used and new batteries.

- Unthread the control box screws to remove the control box cover.
- Unthread the battery box screws to remove the battery box cover.
- Insert four AA batteries (LR06) (provided). Refer to the battery cover for battery orientation.
- Reinstall the battery box cover and secure with the screws.
- Connect the power cords.
- Place the battery box into the empty space within the control box.
- Secure the control box cover to the control box.
- Allow 15 seconds for the sensor to cycle through the automatic sensing distance.

LED Indicator

NOTE: When the faucet is initially connected to a power source, the LED will flash to indicate that the sensor detection range is automatically adjusting. Do not place any objects in front of the sensor for approximately 15 seconds while the sensor is automatically adjusting.

NOTE: The LED on the control valve assembly cover will flash RED every 6 seconds when the DC batteries are running low.

- The LED will flash every 2 seconds when the DC batteries are dead. Replace the batteries.

8. Install the Drain

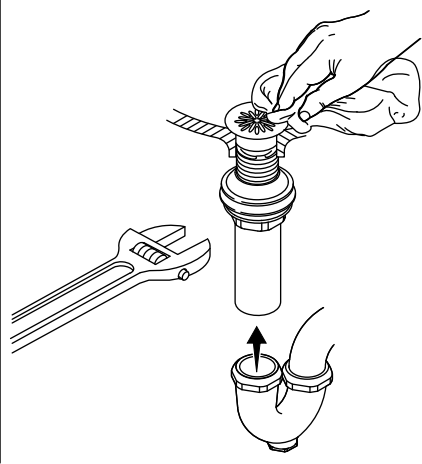
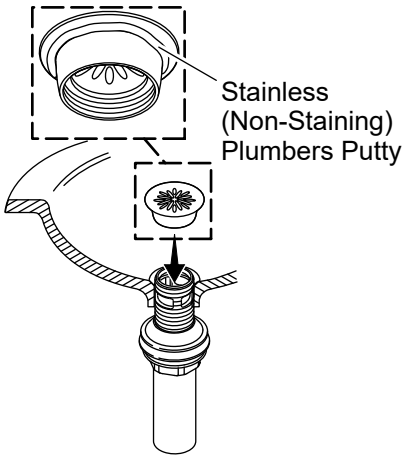

- Disassemble the drain.
- Apply plumbers putty to the underside of the flange and attach.
- Apply thread sealant tape to the drain pipe threads. Tighten the nut.
- Connect the trapway. Wipe away excess plumbers putty.

9. Complete the Installation

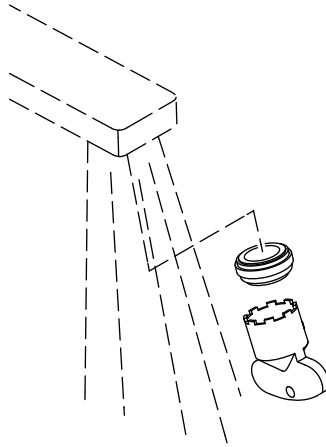

NOTE: Avoid the area in front of the sensor for 15 seconds after connections are complete. The sensor will not function correctly if activated in the first 15 seconds. Disconnect and reconnect the power to reset the sensor.

- If applicable, uncover the drain.
- Temporarily cover the sensor on the faucet or turn OFF the water supplies.
- Uncover the sensors on the faucet or turn ON the water supplies.
- Activate the faucet and check all connections for leaks. Make adjustments as needed.
- Using the provided key, remove the aerator.
- Run water through the spout for 1 minute. Check for leaks and make adjustments as needed.
- Reinstall the aerator using the provided key.

Troubleshooting

This troubleshooting guide is for general aid only. For service and installation issues or concerns, call 400-820-2628.

Symptoms	Possible causes	Recommended Action
1. No water flow.	<p>A. The supply stops are turned OFF.</p> <p>B. No power supply or wrong connection.</p> <p>C. Object in sensing range.</p> <p>D. The sensor lens is dirty.</p> <p>E. The filter screen is plugged.</p>	<p>A. Turn ON the supply stops.</p> <p>B. Check the power supply and connection.</p> <p>C. Remove the object.</p> <p>D. Wipe the sensor lens with a damp soft cloth. Wipe dry with a dry soft cloth.</p> <p>E. Remove and clean the filter screen.</p>
2. Low flow.	<p>A. Supply pressure is low.</p> <p>B. The aerator is plugged.</p> <p>C. The filter screen is plugged.</p>	<p>A. Check incoming water pressure. Pressure should be at least 20 psi (137 kPa).</p> <p>B. Remove and clean the aerator. For calcium/mineral deposits, soak the aerator plastic insert in a 50:50 mixture of vinegar and water. Soak only the insert and no other components.</p> <p>C. Remove and clean the filter screen.</p>
3. Constant water flow.	<p>A. Solenoid valve is not working.</p>	<p>A. Order and install a new solenoid valve assembly.</p>
4. Constant steady drip from the faucet.	<p>A. The solenoid valve diaphragm is damaged.</p>	<p>A. Order and install a new solenoid valve diaphragm.</p>

Symptoms	Possible causes	Recommended Action
<p>5. Intermittent activation.</p>	<p>A. The faucet is angled incorrectly to the deck or misaligned with the user area.</p> <p>B. The wires are pinched or damaged.</p>	<p>A. Verify that the faucet is mounted according to the installation directions. Verify that the faucet is installed in a position that is above the rim of the sink.</p> <p>B. Remove the spout and verify that the wires are tucked inside the spout before reassembling.</p>
<p>6. The sensor flashes once approximately every 2 seconds.</p>	<p>A. The AC connection is not installed correctly.</p> <p>B. Batteries are out of power.</p>	<p>A. Reconnect the AC transformer connection.</p> <p>B. Replace the batteries.</p>

kohler.com.cn

THE BOLD LOOK
OF **KOHLER**®

©2025 Kohler Co.



1596723-T2

1596723-T2-C