

#### 26244T-C9 恒温双花洒淋浴柱-硬管连接(长方形头顶)

#### 安装之前

所有的资料是按最新出版的产品资料编写而成。科勒公司保留任何时候不经通知即可改变产品特性、包装或产品可供类型的权利。

说明书包括重要的安装、保养及清洁方面的内容，请把这些资料交给用户阅读。

#### 注意事项：

1. 最小供水压力：0.05MPa(0.5bar)。
2. 推荐冷热供水的静态压力：0.3MPa(3bar)。
3. 如果供水压力大于0.5MPa(5bar)，安装减压阀。
4. 热供水温度最低：50°C；最高：80°C。
5. 推荐的热供水温度：65°C。
6. 温度的设定基本范围为：20°C到49°C。
7. 安全限位温度：37°C。
8. 最高混合温度：49°C。
9. 花洒最高工作温度及环境温度：60°C。请特别注意花洒同花洒连接的臂管须远离浴霸，否则可能损坏花洒及其密封件，甚至对使用者造成伤害。

#### BEFORE YOU BEGIN

All information is based on the latest product information available at the time of publication. Kohler Co. reserves the right to make changes in product characteristics, packaging, or availability at any time without notice.

Please leave these instructions for the consumer. They contain important information.

#### NOTES:

1. Minimum supply pressures: 0.05MPa(0.5bar).
2. Recommended supply static pressures: 0.3MPa (3bar) on hot and cold water.
3. Supply pressure greater than 0.5MPa(5bar): install a pressure reducer.
4. Hot water temperatures, minimum: 50°C, maximum: 80°C.
5. Recommended hot water temperature: 65°C (energy-saving).
6. Setting range, approximately: 20°C to 49°C.
7. Safety stop at: 37°C.
8. Maximum mixed water temperature: 49°C.
9. The highest environment temperature for handshower & showerhead is 60°C. Please keep the handshower, showerhead and shower arm away from heater, or it may become damaged and cause injury to the user.

#### 使用说明

慢慢旋转温控把手即右把手，调整温度，安全限位温度为37°C。如果想得到更高温度，按住按钮继续逆时针旋转。

顺时针旋转左侧把手切换至头顶花洒出水，逆时针旋转切换至手持花洒出水。

#### OPERATION INSTRUCTIONS

The temperature is set by slowly turning the temperature selector(right-hand handle). For safety reasons, there is a stop that limits temperature to 37°C. To get a higher temperature, push the button and continue turning the temperature selector counter-clockwise. Water flow is set by turning the left-hand handle.

Turn the left-handle clockwise for showerhead, turn counter-clockwise for handshower.

# 安装尺寸

# ROUGH-IN DIMENSIONS

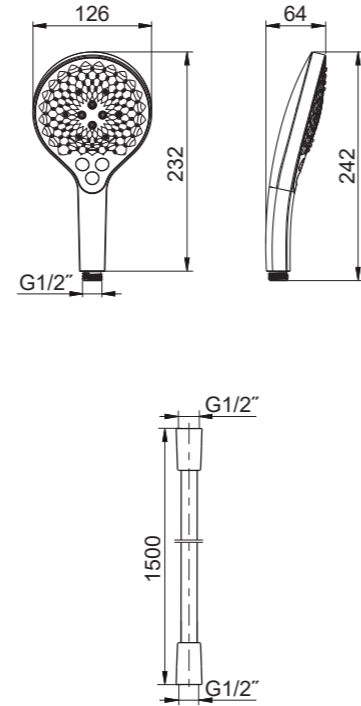
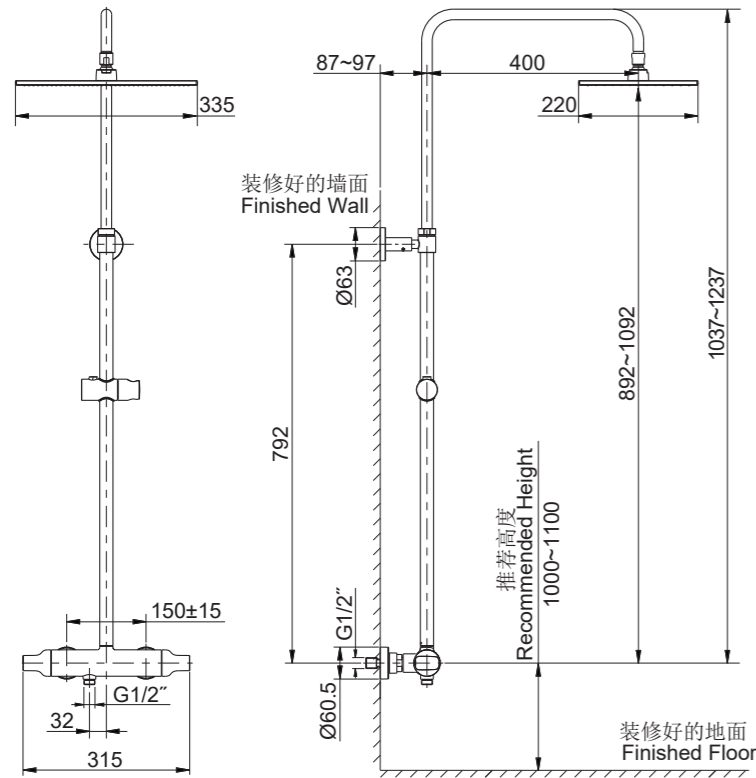

# 安装步骤

## 如何安装水龙头

为使安装顺利，G1/2"内螺纹管道配件应已安装好，预留150mm间距，保持水平。管道配件要垂直并不能凸出装修好的墙面。热供水管装在左边。彻底冲洗供水管，以清除管路中的杂质。

在两个接头(1)涂上密封胶或缠绕足以密封的密封胶带，旋入冷热水管中。调节两个接头，使其中心距离为150mm，并保持同一水平。它们凸出墙面的尺寸应该在33到43mm之间。

将滤网(2)装到接头(1)内。在装饰盖(3)背面边缘涂一圈油灰，将装饰盖装到水龙头螺母(4)上，将螺母旋到接头上。并用带状扳手拧紧。后推装饰盖使其紧贴墙壁。去除多余油灰。

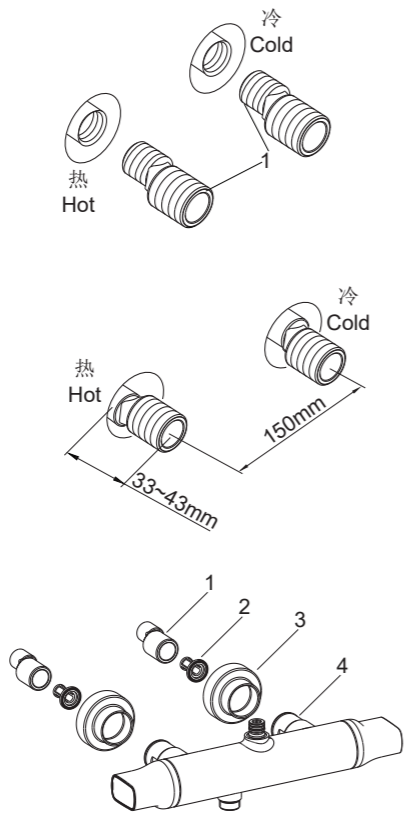

# INSTALLATION

## How to Install the Faucet

To perform installation, installer must provide G1/2" female supply fittings, spaced 150mm apart and horizontally. The supply fittings should be vertical and not beyond the finished wall. Hot supply pipe must be located on the left. Flush the water supply pipes thoroughly to remove debris.

Use appropriate thread sealants or thread tape on the threads of offset connectors(1). Install two offset connectors into the hot and cold supply pipes. Adjust the center-to-center distance between the connectors to 150mm horizontally. They should extend 33 to 43mm beyond the finished wall.

Put the filters(2) into the connectors(1). Apply a ring of putty on back of the escutcheons(3). Install the escutcheons onto the supply nuts(4). Thread the supply nuts onto the connectors and tighten by strap wrench. Push the escutcheons until against the finished wall. Remove any excess putty.

# KOHLER® SERVICE PARTS

# 利奥 ALEO

## 零件图 Thermostatic 2-Way Shower Column - Direct Connection (Rectangle Showerhead)

### 26244T-C9 恒温双花洒淋浴柱-硬管连接(长方形头顶)

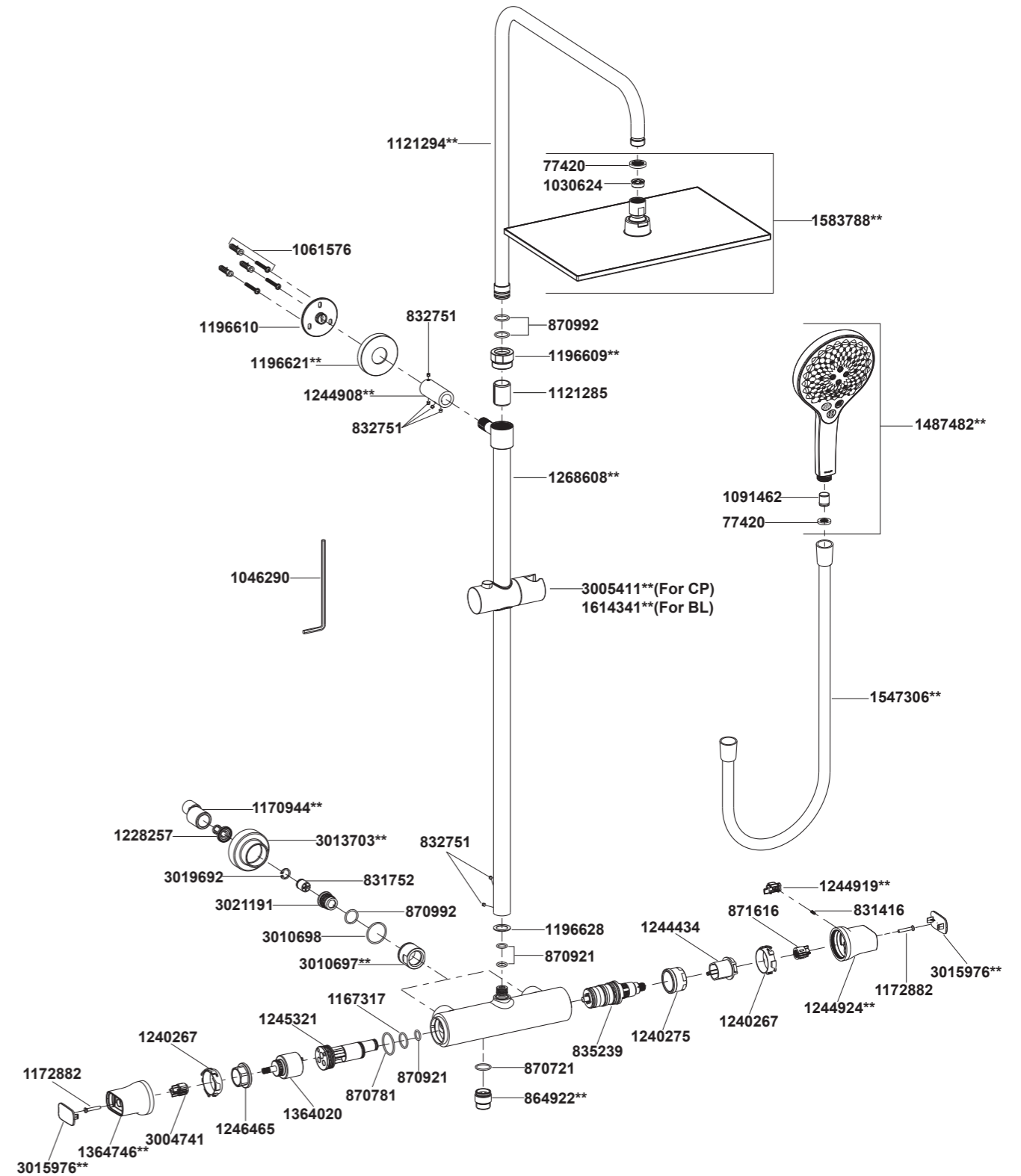

\*\*订购时请说明颜色编号

\*\*Color code must be specified when ordering

## 清洗说明

适用于所有加工处理过的表面：以中性肥皂水清洗镀层表面，再以干净的软布彻底擦干整个表面，许多清洁剂，比如氨水、去污粉及洁厕灵等，会对电镀表面造成伤害，切忌使用。

有磨损性的清洁用具或清洁剂也不可适用于科勒牌的水龙头及其配件上。

## CLEANING INSTRUCTIONS

All Finishes: Clean the finish with mild soap and warm water. Wipe entire surface completely dry with clean soft cloth. Many cleaners may contain chemicals, such as ammonia, chlorine, toilet cleaner etc. which could adversely affect the finish and are not recommended for cleaning.

Do not use abrasive cleaners or solvents on Kohler faucets and fittings.

## 如何安装花洒淋浴柱

试装滑杆组件(14)，以确定底座(6)的安装位置。将连接管(9)与底座(6)连接(注意：底座上的箭头朝上)，并用螺钉(10)锁紧。将连接管另一端套在滑杆组件接头(11)上。

将垫片(15)放到龙头出水口(16)上。连接龙头出水口(16)与滑杆组件(14)。将滑杆组件竖直放置。调整连接管，使滑杆组件平行于墙面。用铅笔在墙壁上标出底座安装孔位。分别拆下滑杆组件和连接管(注意：切勿弄丢螺钉)。

根据胀塞(5)直径在墙面上标记处打孔。放入胀塞，用自攻螺钉(7)固定底座(注意：底座上箭头朝上)。

确认垫片(15)在龙头出水口上。将连接管(9)和装饰罩(8)套在滑杆组件接头上。使滑杆组件下端与龙头出水口相连，上端的连接管套在装好的底座上。保持滑杆组件平行于墙面，用六角扳手(18)锁紧螺钉(10)，旋紧装饰罩直至接触墙壁。用六角扳手锁紧螺钉(17)。

取下弯管组件(12)的保护套并扔掉。将弯管组件装入滑杆组件，然后用带状扳手或用软布垫在普通扳手和螺母之间，将螺母(13)旋紧到滑杆组件上，保持弯管出水口朝前。

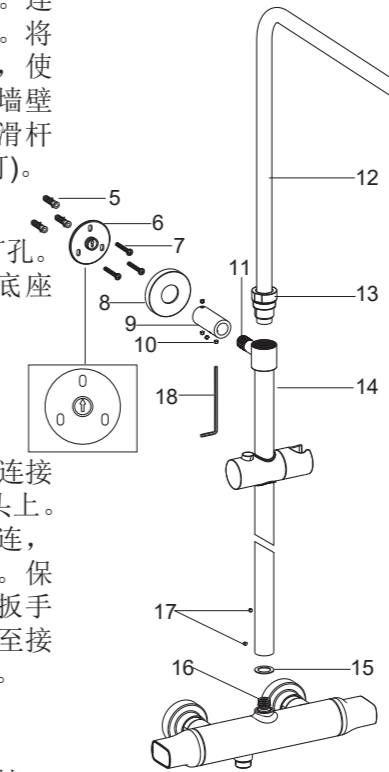

## How to Install the Shower Column

Rehearse slide bar kit(14) installation for the base(6) mounting location determination. Connect the tube joint(9) and the base(6) (Note: The arrow in the base is upward), tighten them with screws(10). Set the other end of the tube joint on the supporter(11).

Put the washer(15) onto faucet outlet(16). Connect the faucet outlet(16) and slide bar kit(14). Place the slide bar kit upright and parallel to the finished wall. Mark the holes of base with a pencil on the finished wall. Uninstall the slide bar kit and tube joint. (Note: Don't lose the screws.)

Drill holes in the finished wall according to the diameter of the anchors(5) and the position of mounting base. Insert the anchors into the holes. Secure the mounting base by self-tapping screws(7). (Note: The arrow in the base is upward).

Ensure the washer(15) on the faucet outlet. Install the tube joint(9) and escutcheon (8) onto the supporter. Connect the slide bar kit and faucet outlet. Slide the tube joint onto the base. Make sure the slide bar kit is parallel to the finished wall. Tighten the screws(10) with hex wrench(18). Screw the escutcheon until it against wall. Tighten the screws(17) with hex wrench.

Remove and discard the guard from the tube kit(12). Install the tube kit into the slide bar kit. Then screw the nut(13) onto the slide bar kit with strap wrench or soft cloth between the nut and regular wrench. Make sure the outlet of the tube kit faces front.

## 如何安装手持花洒

安装手持花洒(19)之前，调整切换把手至手持花洒出水状态，并打开冷热水源冲掉管路中的杂质。

根据需要将单向阀(20)塞入手持花洒进水口，将滤网垫片(21)放入软管(22)接头内，用软管连接接头(23)和手持花洒。锁紧所有衔接螺母。

将手持花洒挂在花洒挂架(24)上。

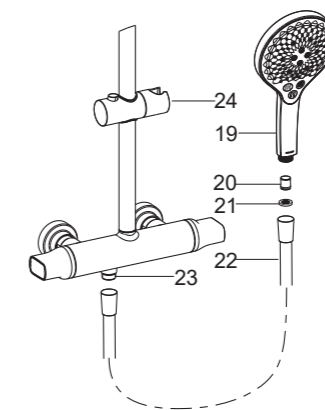

## How to Install the Handshower

Ensure that the position for handshower(19). Flush hot and cold water supplies to remove any debris before the handshower is installed.

Put the check valve(20) into the handshower if needed. Put the screen washer(21) into the shower hose(22). Connect the connector (23) and handshower with hose. Tighten all the connectors.

Hang the handshower on the shower bracket(24).

## 如何安装头顶花洒

安装头顶花洒(25)前, 旋转左把手至头顶花洒出水状态, 打开冷热水源冲掉管路中的杂质。

根据需要安装限流器(26)。先取出垫片(27), 按图示方向放入限流器, 再装回垫片。将头顶花洒旋到弯管组件出水口(28)上, 用带状扳手锁紧。

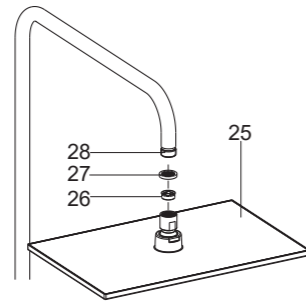

## How to Install the Showerhead

Ensure that it is in the position for showerhead(25). Flush hot and cold water supplies to remove any debris before the showerhead is installed.

Before installation, put the regulator(26) into the showerhead inlet if needed. Take out the washer(27) and install the regulator as shown, reinstall the washer. Tighten the showerhead onto the tube kit outlet(28) with strap wrench.

## 安装结果检查

检查并确保所有衔接螺母都已锁紧。确定手柄在关闭位置。开启主水源, 检查是否有漏水。如有漏水, 修理之。

## INSTALLATION CHECKOUT

Ensure that all coupling nuts are tight. Close the valves. Turn on the main water supply, and check for leaks. Repair as needed.

## 维护与保养

### 温度测试与调整

温度测试前, 应确保供水系统充分且具有较高的温度。温度把手在37°C位置时, 打开龙头让水流出。进行温度测量, 出厂时温度设定在36~38°C范围内。如超出这个范围, 要进行调整。

调整步骤如下:

取下把手上盖, 用螺丝刀取下螺钉, 拔出温控把手组件。

在正常水流状态下, 由冷水位置开始慢慢转动温控阀轴(保持同一方向)直至获得37°C水流。如温度超过38°C, 回到冷水位置重新调整。温度稳定后, 不要转动温控阀轴, 将轴套上的凸起对准本体上的凹槽装入。安装温控把手, 使得温控把手上的圆形激光标与本体上的数字37对齐。如图示锁紧螺钉, 安装把手上盖。

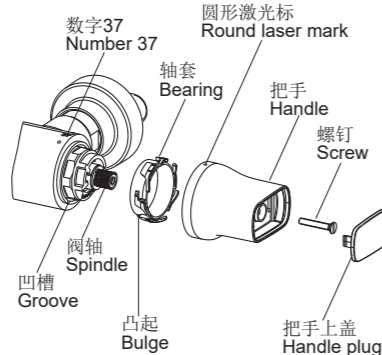

### Verification and Setting

Make sure the water feeds of the faucet have reach the highest temperature by running the water sufficiently. When the selector in position 37°C, the water temperature should be within a range of 36°C between 38°C, as measured by a thermometer. If not, the installer can adjust the setting.

Proceed with the setting as follows:

Remove the handle plug. Uninstall the screw with screwdriver.

Under the normal condition of water flow, slowly turn the temperature selector (always in the same direction) from the cold water position until the water temperature reaches 37°C. If the temperature goes over 38°C, go back to the "cold" setting and reset it. When the temperature is stable, do not turn the cartridge spindle. Make sure the bulge of the bearing is aligned with the groove of the body. Insert the bearing. Make sure the round laser mark on the temperature handle is aligned with the number 37 on the faucet body. Tighten the screw. Install the handle plug as shown.

## 如何清洗滤网

滤网垫片(2)可起到保护水龙头的作用, 但长时间使用后, 水垢或杂质可能会堵塞滤网, 降低水流量。

如有类似情况发生, 卸下龙头取出接头(1)内的滤网。用热醋清洗滤网。然后按照图示装回。

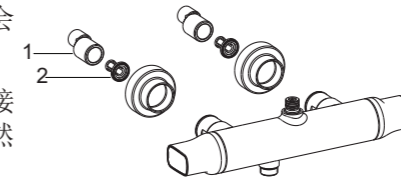

## How to Clear the Filter

The filters(2) can protect the faucet, but it may get obstructed and reduce water flow after a long time of use.

If this happens, take out the filters in the connectors(1) after removing the faucet. Clean the filters by soaking them in warm vinegar. Reinstall them as the figure shown.

## 如何清洗温控阀

如果供水的水质较硬或长时间使用, 水垢或杂质会阻塞温控阀上的滤网, 流量会降低。需要清理请按照下列步骤进行:

关闭供水系统, 使流量阀处于打开位置后进行温控阀的拆卸作业。温控阀是较敏感的配件, 要十分小心。

拆卸前确保指示标识与数字37对齐。取下把手上盖, 用螺丝刀取下螺钉, 拔出温控把手组件, 取下轴套(Fig.1)。

将螺母和塑料套卸下。小心地卸下温控阀(Fig.2)。用热醋进行清洗。

清洗后, 将塑料套和螺母(限位组件)装到温控阀上, 使塑料套上的定位柱嵌入温控阀的限位槽内(Fig.3)。

将塑料套上的定位柱与龙头本体孔凹槽对齐, 装入温控阀并锁紧螺母(Fig.4)。

**注意:** 确保拆卸、安装过程中不要转动温控阀轴。如不小心转动了阀轴, 要调整阀轴使外齿上的圆孔标识与相邻的塑料套上的凹槽对齐(Fig.5), 或者按前述方法进行调整。

不要转动温控阀轴, 安装温控把手, 使参考标识同数字37对齐, 拧紧螺钉。安装把手上盖(Fig.1)。

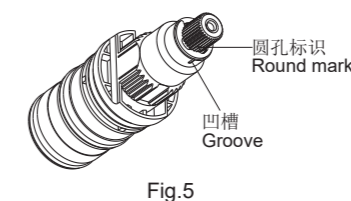
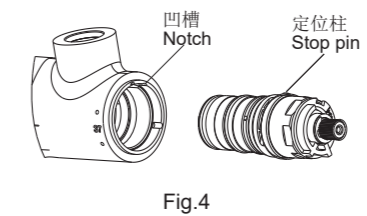
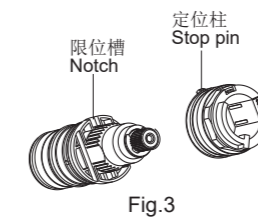
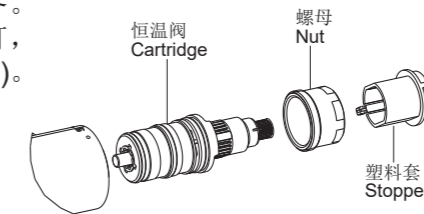
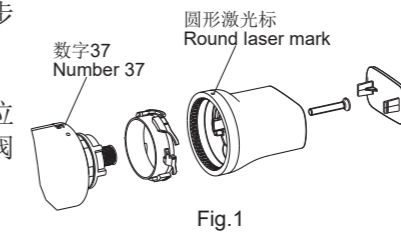

## How to Clear the Thermostatic Cartridge

Very hard water can obstruct the filters on the thermostatic cartridge and reduce the water flow. Please clean the cartridge as follows:

Shut off the water supply and turn on the water flow handle, then remove the cartridge. The cartridge is sensitive part, please be careful.

Before your action, ensure the reference mark is aligned with number 37 before your action. Remove the handle plug. Uninstall the screw with screwdriver. Remove the handle kit and bearing. (Fig.1).

Unscrew the nut and stopper. Remove the cartridge cautiously(Fig.2). Clean the thermostatic cartridge by soaking it in warm vinegar.

After cleaning, install the "stop assembly" back on the cartridge, adjust the stop pin into the notch(Fig.3).

Install the assembly cartridge and stop in the body, adjust the stop pin into the notch(Fig.4).

**NOTE:** Do not turn the cartridge when reinstalling it. If you turned it accidentally, you should adjust it and be sure that the round mark is correctly in line with the groove(Fig.5), or readjust as per the steps of verification and setting.

Do not turn the cartridge spindle. Ensure the number 37 is aligned with the reference mark. Tighten the handle with the screw. Put on the handle plug(Fig.1).