



BEFORE YOU BEGIN

- Please read these instructions carefully to familiarize yourself with the required tools, materials, and installation sequences. Follow the sections that pertain to your particular installation. This will help you avoid costly mistakes. In addition to proper installation, read all operating and safety instructions.
- All information is based on the latest product information available at the time of publication. Kohler China Ltd. reserves the right to make changes in product characteristics, packaging, or availability at any time without notice.
- We recommend this bath for drop-in or 3-wall alcove installations.
- This bath must be installed to an adequately supported, level subfloor.
- These instructions contain important care, cleaning, and warranty information-**please leave these instructions for the consumer.**

 **CAUTION: Risk of personal injury.** Cast iron baths are very heavy. Get help lifting and moving the bath.

安装之前

- 请仔细阅读此说明书以熟悉所需要的工具、材料及安装顺序。遵循适合您的特定安装要求的各项内容，避免昂贵的损失。除了要正确安装外，还应阅读操作及安全说明。
- 所有的资料是按最新出版的产品资料编写而成。科勒中国有限公司保留任何时候无须通知即可改变产品特性、包装或产品可供类型的权利。
- 我们建议采用嵌入式或三面嵌墙式安装此浴缸。
- 浴缸必需安装在有足够强度的水平底层地板上。
- 说明书包括重要的保养、清洁及担保方面的内容，请把这些资料交给用户阅读。

 **警告：小心人员受伤。** 铸铁浴缸十分沉重。须请人帮助搬动。

PRODUCT REQUIREMENTS

A. Summary Of Key Requirements

- Observe all local plumbing codes.
- Install this bath on an adequately supported, level subfloor. When replacing an existing bath, check floor under bath for damage and repair as needed.
- Provide properly dimensioned framing.

B. Product Inspection

Uncrate and inspect bath for damage. Leave all materials in the crate during construction to prevent damage.

产品要求

A. 关键要求的总结

- 请遵守当地的卫生管道施工规范。
- 浴缸必须安装在有足够支撑的水平底层地板上。当更换旧浴缸时，检查地板是否有损坏，并加以修补。
- 提供尺寸正确的框架结构。

B. 产品检查

小心地打开包装箱并检查浴缸是否损坏。施工期间将所有的材料都留在箱内，以防止损坏。

K-18200T/K-18200T-GR

UNIT: mm
单位: 毫米

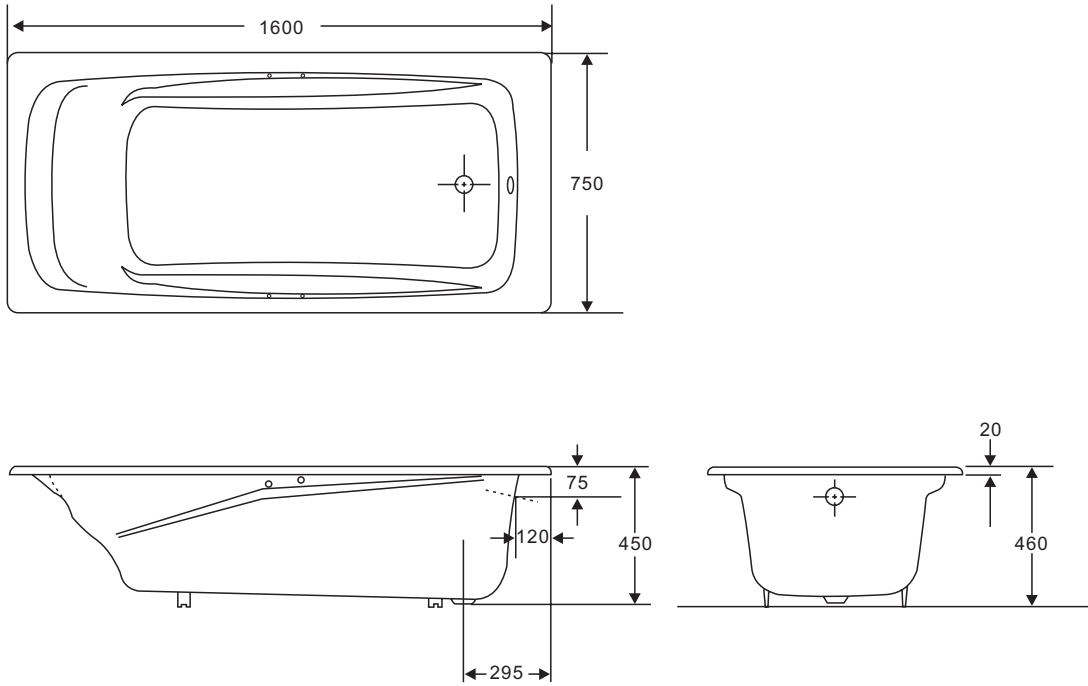

Specifications

规格

Cut-out Dimensions	1562mm × 712mm
Drain	K-17295T-CP
Weight	119kg
GripRail	K-8597T-CP
Water Capacity to Bottom of Overflow	176L
Water Capacity to Edge of Rim	252L

切割图尺寸	1562毫米 × 712毫米
排水	K-17295T-CP
重量	119公斤
扶手	K-8597T-CP
满水容量(至溢水口)	176升
满水容量(至顶端)	252升

K-18201T/K-18201T-GR

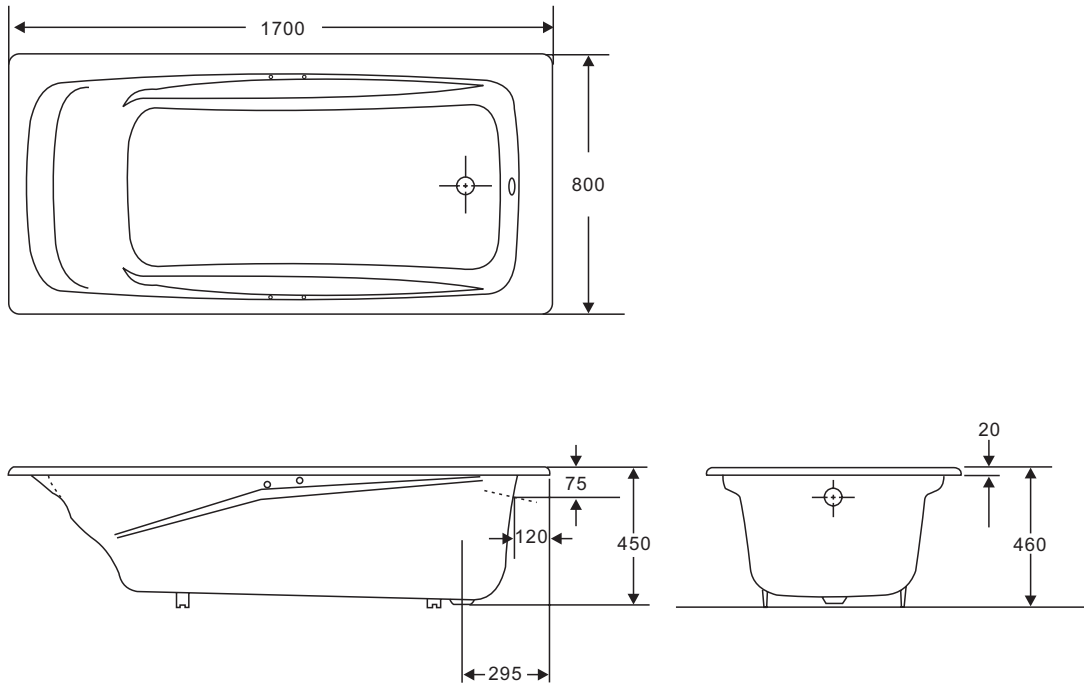

Specifications

Cut-out Dimensions	1662mm × 762mm
Drain	K-17295T-CP
Weight	128kg
GripRail	K-8597T-CP
Water Capacity to Bottom of Overflow	206L
Water Capacity to Edge of Rim	289L

规格

切割图尺寸	1662毫米 × 762毫米
排水	K-17295T-CP
重量	128公斤
扶手	K-8597T-CP
满水容量(至溢水口)	206升
满水容量(至顶端)	289升

Notes

Fixture dimensions are nominal and conform to tolerances by ANSI standard (A112.19.1).

注意

产品尺寸为公称尺寸，误差符合ANSI标准(A112.19.1)。

INSTALLATION REQUIREMENTS

安装要求

A. Recommended Tools And Materials

- Silicone Sealant
- Measuring tape
- Pencil
- Plumber putty
- Square
- Safety glasses
- Pipe wrench
- Philips Screwdriver
- Level

Plus:

- Conventional Woodworking tools and materials
- Drop cloth

A. 推荐工具及材料

- 密封硅胶
- 卷尺
- 铅笔
- 管道油灰
- 直角尺
- 护眼镜
- 管钳
- 螺丝刀
- 水平仪

此外:

- 传统木工工具及材料
- 抹布

B. Clearance Requirements

Check the rough-in and room dimensions to provide adequate available space for the bath unit.

B. 预留尺寸

检查安装尺寸及浴室尺寸，确保有充分的空间安装浴缸。

SITE REQUIREMENTS

场所要求

A. Old Bath Removal (if necessary)

Disconnect the drain at the trap. Remove the old wall material. Slip boards under the old bath feet to protect the floor, and slide the old bath out of the recess as illustrated.

A. 拆除旧浴缸 (如有必要)

在存水弯处拆下排水管，清除所有旧墙材料。在旧浴缸下面塞入护板以保护地面，并按如图所示把旧浴缸从安装空间拉出。

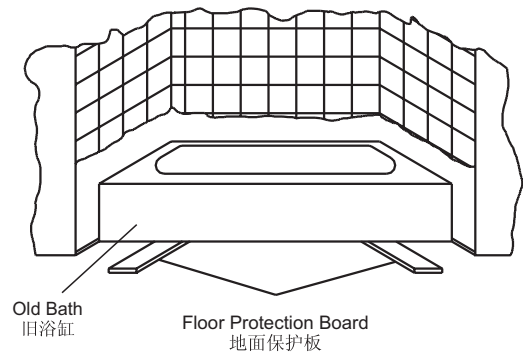

B. Subfloor Preparation

Check the flooring under the bath, and make repairs as needed. Make sure the subfloor is level.

B. 未完工地板的准备

检查浴缸下的地板，若需要请进行修补。请确保未完工地板的水平。

C. Plumbing Preparation

Position the plumbing according to rough-in dimensions. Cap the supplies and check for leaks.

C. 管道的准备

将管道按安装尺寸安置。堵塞供水管并检查是否漏水。

A. The following installation practices **must be followed** to avoid any potential damage to the enamel finish.

WARNING: Failure to follow the manufacturer's recommended installation method may result in damage to the enamel surface.

- Do not use sharp objects or metal tools when handling the bath, especially around the rim area.
- Use a clear protective plastic film over tub rim as well as the bottom of tub to safeguard from dirt and silicone during the installation process.
- For correct installation, bath rim should not come in direct contact with the walls and/or horizontal surfaces to avoid transmission of noise and vibration as well as potential cracks in the enamel finish.
- The necessary gap between bath rim and the wall is 2 mm horizontally and 4 mm vertically. Refer to figures 1, 2, and 3 below.
- Before placing setting-in the bath, apply a sanitary quality silicone filler on all surfaces to come in contact with the bath rim.
- Set the bath in its correct position.

UNIT: mm
单位: 毫米

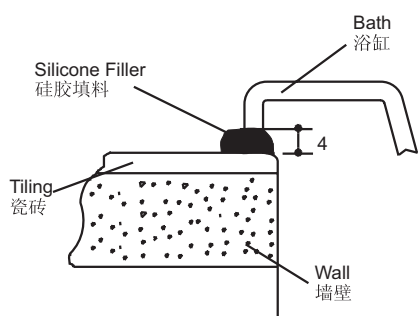

Fig.1
图1

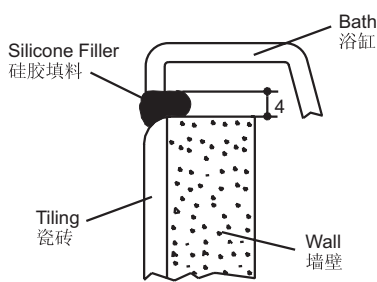

Fig.2
图2

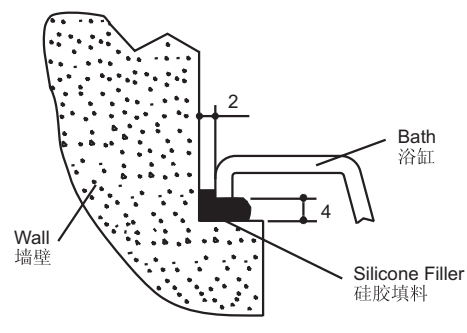

Fig.3
图3

A. **必须遵守**下列具体安装要求，以避免引起对搪瓷表面任何潜在的损坏：

警告：如果不按照厂家要求的安装方法执行，将会造成搪瓷表面的损坏。

- 在搬运浴缸时，特别是在浴缸边缘附近，切勿使用尖锐的物体或工具。
- 在浴缸边缘及底部盖一层透明塑料布，以防止在安装过程中，污垢及硅胶粘贴在浴缸上。
- 正确的安装方法，应该使浴缸边缘不要与墙壁或水平表面直接接触，以防止传播噪音和振动，并避免引起搪瓷表面可能的破裂。
- 浴缸边缘与墙壁之间必须在水平方向至少留有2毫米的间隙，在垂直方向至少留有4毫米的间隙。请参考以下图1、图2、图3。
- 放置浴缸前，在与浴缸边缘相接触的所有表面，涂抹一层高质量的卫生硅胶填料。
- 将浴缸安置在正确的位置上。

B. Partially Install Bath Drain

- Install the drain on the bath according to the drain manufacturer's instructions.

B. 局部安装浴缸的排水配件

- 按照厂家说明书，把排水配件部分安装在浴缸上。

A. Through the Floor Drain Bath Installation

- 1). Slide the new bath into position to verify the drain location and the stud fit. Cut a minimum 152 × 305 mm hole in the floor for the drain connection.

A. 排水管通过地板的浴缸安装

- 1). 将新浴缸放置在安装位置以了解排水孔和浴缸底脚的位置。在地板合适的位置为排水管开出一个152 × 305mm 的长方孔。

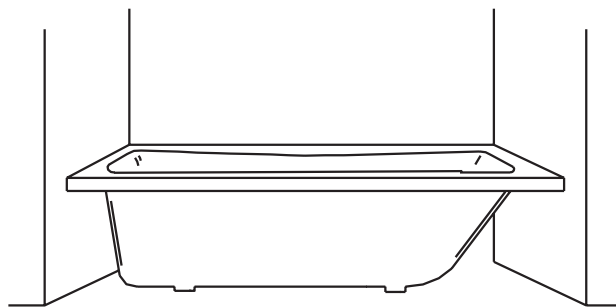

- 2). Use 25~30 Kg dry cement and sand mix. Add water to make a paste mortar. Remove the tub. Cover the installation area with the mortar starting from the middle of the tub as shown. The height of the mortar should reach the bottom of the tub.

NOTE: DO NOT CLOG THE DRAIN HOLE.

- 3). Place the tub onto the mortar. Insert the drain tailpiece into the trap.
- 4). Make sure that the bottom of the tub is pressed into mortar in order to secure the tub. Insert two wood wedges under the tub to support the weight of the tub until the mortar hardens. (Wedges will remain in the mortar.) Frequently check the level of the tub.

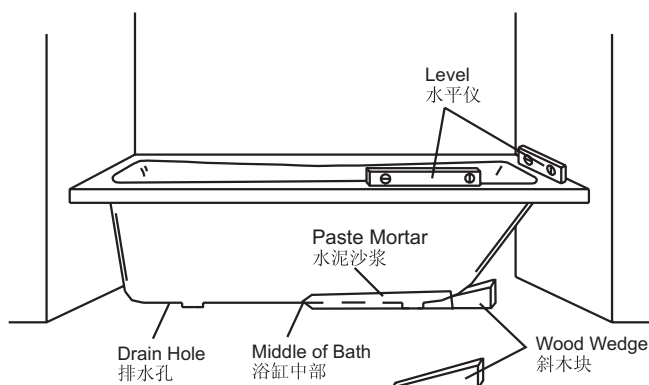

- 2). 用25~30公斤的干水泥及砂，加水调成稠水泥沙浆。将浴缸移出，用水泥沙浆从浴缸中部覆盖至无排水口一端的安装区域，如图所示，水泥沙浆的高度应能与浴缸的底面接触。

注意：避免将排水口堵塞。

- 3). 将浴缸放置在预先测好的位置，把排水管尾端插入存水弯管。
- 4). 将浴缸底部紧压在水泥沙浆上以固定浴缸。在浴缸底部插入两个斜木块来支撑浴缸。水泥沙浆干涸后，斜木块还应留存其内。装置时，请随时用水平仪校正浴缸的水平度，使浴缸保持水平。

B. Install Plumbing

CAUTION: Risk of damage to bath bottom and subfloor. Ensure a watertight seal on the bath drain connections.

- 1). For through the floor drain installation, when the bath is securely positioned, connect the drain to the trap as shown.
- 2). Install the faucet valving and spout tee. Open the hot and cold water valves, and check the supply connections for leaks.
- 3). Run water into the bath, and check the drain connections for leaks.

B. 安装卫生管道

注意：避免损坏浴缸底部和底层地板。浴缸的所有排水接口都要确保做防渗密封。

- 1). 对于排水管通过地板的安装，当浴缸固定到位后，将排水管与存水弯相接，如图所示。
- 2). 安装水龙头阀门及喷头三通。打开冷水及热水阀门，检查所有给水管接头是否有渗漏。
- 3). 让水流入浴缸，检查排水配件接头是否有渗漏。

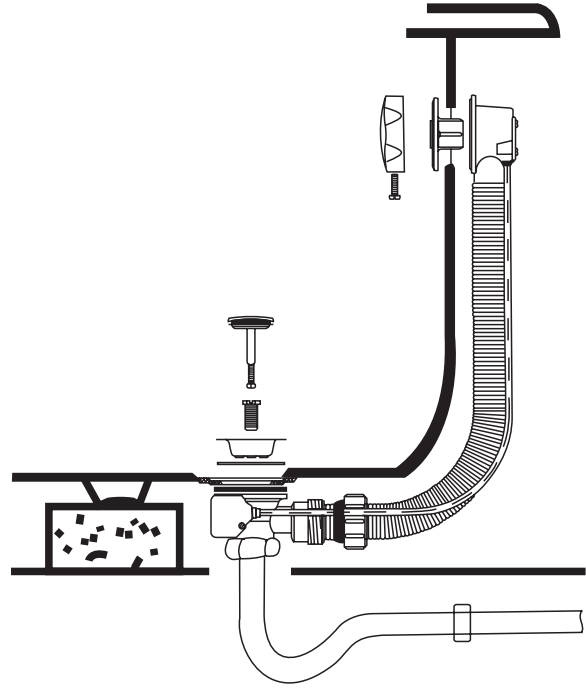

C. Finish Bath Area Construction

NOTE: An access panel is essential for future maintenance. Possible framing arrangements are illustrated below. Use the framing construction appropriate for your particular bath model. Some modifications may be needed for other types of construction, if preferred. If an apron wall without a ledge is desired, the finished apron wall surface must be 2 mm under the bath rim.

C. 完成浴缸周围的结构

注意：为方便以后维修，一定要安装一个检修门。

下图所示为几种常用结构，请采用适合您的浴缸型号的结构。对不同的结构，也许有必要进行适度调整。

如果选择与浴缸边缘齐平的裙板墙，完工后裙板墙的高度应低于浴缸边缘2mm。

Recommended For Drop-in Models

下列建议适合为无裙边浴缸使用

1). Corner Installation

The suggested framing construction is illustrated.

1). 墙角安装

右图为建议的结构。

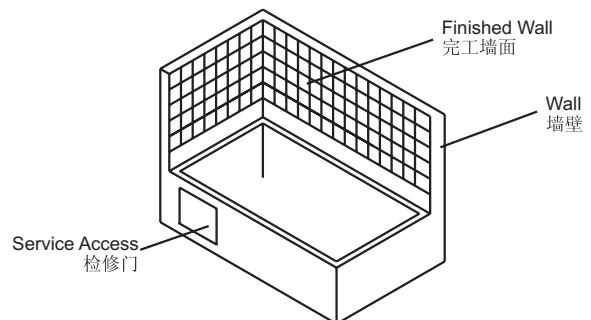

2). Recess Installation

The suggested framing construction is illustrated.

2). 三面靠墙安装

建议的三面墙环围的结构如图所示。

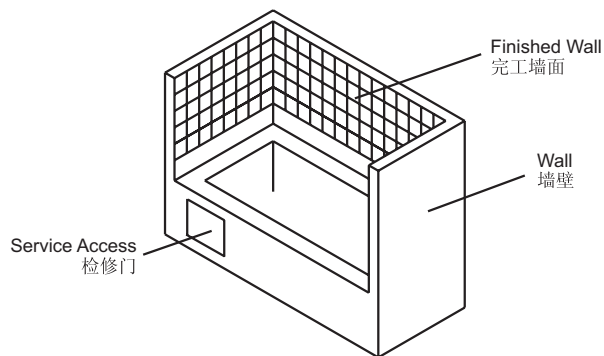

3). Peninsular Installation

The suggested framing construction is illustrated.

3). 单面靠墙安装

建议的单面墙结构如图所示。

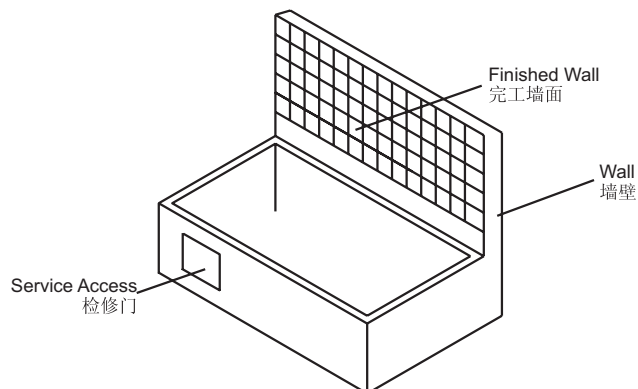

COMPLETE FINISH WALL

完成墙壁装修

CAUTION: Risk of product damage. Do not support the weight of the bath by the rim.

Install the ceramic or marble tiles. Seal the joints between the bath rim and the finished tiled wall using silicone sealant. RTV (Room Temperature Vulcanizing) sealant is recommended.

注意：当心损坏浴缸。不要靠浴缸边缘支撑浴缸的重量。安装墙壁贴面(如瓷砖或大理石贴面)。用硅胶密封浴缸边缘和贴面的连接处。建议使用常温下硬化的密封胶。

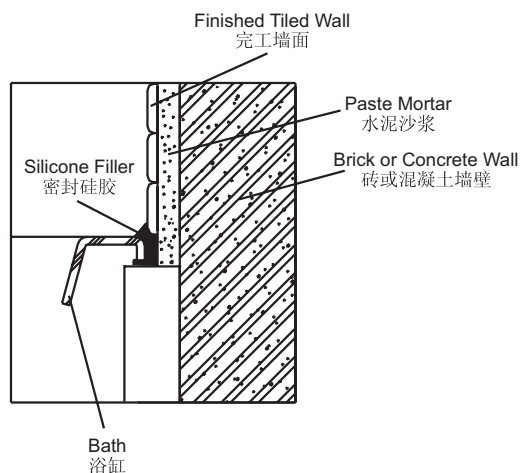

CARE AND CLEANING

When cleaning up after installation, do not use abrasive cleansers, as they may scratch and dull the bath surface. Use warm water and a liquid detergent to clean the surface.

Remove stubborn stains, paint, or tar with turpentine or paint thinner. Do not allow cleaners containing petroleum distillates to remain in contact with any bath surface for long periods of time.

Remove plaster by carefully scraping with a wood edge. Do not use metal scrapers, wire brushes, or other metal tools. Use a powder type detergent on a damp cloth to provide mild abrasive action to any residual plaster.

Clean the outside surface of your vitreous china product with mild soap and warm water. Wipe the entire surface completely dry with a clean, soft cloth.

If the surface of your vitreous china product becomes excessively dirty, you can use a general purpose cleaner such as: Fantastik® Lysol® Foaming Disinfectant, Dow Bathroom Cleaner Liquid, Scrub Free® Soap Scum Remover, Soft Scrub® Spic and Span, or Mr. Clean®.

维护与清洁

在完成安装后进行清理时，切勿使用腐蚀性的清洁剂，以免擦伤浴缸表面，失去光泽。使用温水和非腐蚀性的液体清洁剂来清洁浴缸表面。

顽固的污渍，油漆，或者柏油可以用松节油或油漆稀释剂来去除。切勿让含有汽油提炼物的清洁剂长时间接触浴缸表面。

灰浆可以用木片刮除。请勿使用金属刮刀，钢丝球，或其他金属工具。对于残留的灰浆，可以用湿布蘸些粉末状清洁剂，轻轻擦去。

使用中性肥皂和温水清洁釉面陶瓷产品的表面，用一块干净柔软的抹布把整个表面完全擦干。

如果釉面陶瓷产品表面过脏，可以使用一些常规的清洁剂进行清洁。

IMPORTANT CONSUMER INFORMATION

Housekeeping Responsibilities

The Safeguard slip resistant surface on this bathtub meets or exceeds the requirements of ASME/ANSI for slip resistance.

DANGER!! Improper maintenance or cleansers may permanently remove the slip resistant surface on Kohler bathtubs.

NOTICE: All housekeeping and maintenance employees must be trained in the proper cleaning of Kohler bathtubs. Post a copy of this notice in a readily-visible location.

DO NOT use steel wool, wire brushes, metal scrapers or abrasive sponge pads to clean a Kohler bath tub.

DO NOT use buffing machines on the slip resistant surface.

DO NOT use high alkaline or strong acid cleansers. **DO NOT** use abrasive cleansers.

- Use only non-abrasive cleansers and a soft nylon brush to clean the slip resistant surface.
- When using commercial cleansers, use cleansers with a pH of between three and eight.
- Follow cleanser manufacturer instructions very carefully.

重要的用户资料

用户的责任

浴缸的 Safeguard 防滑表面达到或超过 ASME/ANSI A112.19.1M 对防滑表面的要求。

危险！！ 不适当的维护或清洁剂的使用可导致科勒浴缸的防滑表面永久失去。

注意：所有的清洁和维修人员都应当进行正确清洗科勒浴缸的培训。请将此注意事项的复印件张贴在显著的位置。

请勿 使用钢丝绒，钢丝刷，金属刮刀或有磨损性的海绵垫清洗科勒浴缸。

请勿 在防滑表面上使用抛光仪器。

请勿 使用强碱或强酸性的清洁剂。
请勿 使用磨损性的清洁剂。

- 请使用没有磨损性的清洁剂和软尼龙刷清洗浴缸的防滑表面。
- 请使用 pH 值 3 和 8 之间的清洁剂 (若要使用商业用清洁剂时)。
- 请仔细按照清洁剂生产厂家的说明书进行清洗。

LIMITED ONE-YEAR WARRANTY

Plumbing Fixtures and Fittings Limited One-year Warranty

Kohler plumbing fixtures and fittings are warranted to be free of manufacturing defects.

This product is warranted for one year from date of purchase. Kohler China will be responsible for any problems caused by manufacturing defects provided with the invoice. Kohler China will, at its election, repair, replace or make appropriate adjustment where Kohler China inspection discloses any such defects occurring in normal usage within one year after purchase.

Implied warranties including that of merchantability and fitness for a particular purpose are expressly limited in duration to the duration of this warranty, Kohler China disclaims any liability for special, incidental or consequential damages. Damages to the product caused by misuse, abuse and installation that is not in accordance with the owner's manual are not covered by this warranty.

To obtain quick warranty service, please contact your dealer, or write to Kohler China. (Original sales receipt must be provided as the proof of purchase.)

Kohler China Investment Company Ltd.
Central Customer Service Center
19/F, Shanghai Square, 138 Huai Hai
Road, Luwan District, Shanghai, PRC
Zip Code: 200021

This is our exclusive written warranty.

一年有限担保

陶瓷及浴缸产品及配件担保——一年有限担保

科勒公司担保其陶瓷及浴缸产品及配件在制造工艺上无瑕疵。

本产品自购买之日起即获得本公司一年的质量保证。在质保期内，凭购货发票，科勒公司将免费承担由制造质量引起的任何问题。经核查后，科勒中国有限公司有权决定是修理、更换、还是作适当的调整。

这里所指的担保，包括产品，都已明确地限制在该担保期之内。科勒中国有限公司对其后出现的损坏不负有任何责任。担保也不包括外观损伤、使用不当以及未按说明书安装的损失。

为获得快捷的担保服务，请联系您的销售商；您也可写信给科勒中国有限公司(请出示销售发票原件作为购货凭证)：

科勒(中国)投资有限公司
中央客户服务中心
上海市卢湾区淮海中路138号
上海广场19楼
邮编：200021

这是我们全部的书面担保。