

Operation and Maintenance Manual

(Translation of the original Operation and Maintenance Manual)

KD27V12

From serial number 2016160001

KOHLER®

EN_US
33521029401_8_1
12-2023

KOHLER.
EMISSION CONTROL WARRANTY STATEMENT (USA)

For the United States only

EMISSION WARRANTY

Kohler warrants to the initial and subsequent owners of a stationary equipment certified diesel engine that such engine is:

- Designed, manufactured and equipped to conform at the time of sale with all applicable emission regulations adopted by the United States Environmental Protection Agency (“EPA”) under Section 213 of the Clean Air Act.
- Free from defects in materials and workmanship with respect to the warranted emission control system and components for a period of five (5) years or 3000 hours of total operation by all persons, whichever event occurs first, after date of delivery to the initial owner. If any warranted part that is scheduled for replacement as required maintenance fails prior to the first scheduled replacement point for that part, that part will be repaired or replaced by Kohler. If a component of the emission control system fails during the warranty period, it will be repaired or replaced under warranty and warranted for the remainder of the warranty period. Kohler will provide the repair or replacement of any component warranted to the stationary equipment engine owner. The warranty period begins on the date the engine (in service) or machine (in production) is delivered to the initial owner, and upon any sale of the engine by such initial owner to a subsequent owner, the warranty period does not restart, but rather the remaining balance of the warranty period transfers to the subsequent owner.

WARRANTED PARTS

The following parts (as equipped) are warranted under this warranty for all Kohler engines:

- Fuel Injection System
- Air Induction System
- Turbocharger System
- Charge Air Cooling System
- Exhaust Gas Recirculation (EGR) System
- EGR Control System
- Exhaust Manifold
- Ignition System
- Diesel Particulate Filter System
- Diesel Oxidation Catalyst
- Fuel Additive Devices or Exhaust Aftertreatment Devices
- Selective Catalyst Reduction
- Reductant Containers
- Electronic Control Unit, Sensors, Solenoids, and Wiring Harnesses
- Emission Control Information Label
- Crankcase Ventilation Valves

RESPONSIBILITIES & LIMITATIONS

This warranty is subject to the following conditions.

Kohler’s Responsibilities:

In case an emission-related defect is found in a warranted component during the warranty period, Kohler will provide:

- New, remanufactured, or properly repaired components, approved pursuant to applicable regulations, required to correct the defect.
- Reasonable and customary labor as established by Kohler, during normal working hours, required to make the warranted repairs, including labor to remove and install the engine, if so required.
- Parts replaced under this warranty become the property of Kohler.

Owner’s Responsibilities:

-
- During the warranty period, the owner of the stationary equipment engine is responsible for:
- Premium or overtime labor costs.
 - Costs to investigate engine problems which are not caused by a defect in Kohler's material or workmanship.
 - Kohler may deny warranty coverage if the stationary engine or a part thereof has failed due to abuse, neglect, improper maintenance, or unapproved modifications.
 - Providing timely notice of a warranted failure to an authorized Kohler Dealer, and to promptly make the equipment or engine available to the Kohler Dealer for repair.
 - Proper scheduled and preventive maintenance as outlined in the Operation & Maintenance Manual supplied with the equipment. This includes, but is not limited to, valve adjustment, fuel and oil filter changes, and any other maintenance procedure related to emission control.
 - Using only the proper fuel in the engine, as specified in the Operator's Manual. Engines other than Tier 4 certified engines shall only be operated on commercially available diesel fuel. The Tier 4 certified engines shall only be operated on ultra-low sulfur diesel fuel. Use of any fuel in any engine other than the permitted fuel specified above and in the Operator's Manual would harm the engine's emission control system and may result in the engine no longer operating in compliance with EPA requirements. Therefore, use of any fuel in any engine other than the permitted fuel specified above and in the Operator's Manual is prohibited and will invalidate this warranty.
 - The owner is responsible for initiating the warranty process. Owners are advised to contact their local authorized Kohler Dealer to perform warranty service as soon as a problem arises. The warranty repairs should be completed by the authorized Kohler Dealer as expeditiously as possible.

EXCLUSIONS

This warranty does not cover:

- **This warranty shall only apply** to KOHLER Co. engines.
- Malfunctions in any part caused by abuse, misuse, alterations, tampering, disconnection, or improper or inadequate maintenance.
- Attachments, accessories or components not supplied or approved by Kohler.
- Damage resulting from fire, accident, negligence, act of God or other events beyond the control of Kohler.
- Consequential damages such as loss of use of the engine or equipment powered by the engine, towing, machine transportation, loss of time, downtime, inconvenience, telephone, travel, lodging, or any other indirect or direct damages.
- Loss or damage to personal property, loss of revenue, commercial loss or any other matters not specifically included in this warranty statement.
- Any warranted part that was required to be previously replaced as part of required scheduled maintenance.
- Owner's unreasonable delay in making the equipment available after being notified of a potential product problem.
- Engines installed outside United States of America.

This warranty is in addition to the Kohler Standard Warranty and any extended warranty (if applicable) for the equipment and engine involved. Remedies under this warranty are limited to the provisions as specified in this warranty statement.

IN NO EVENT SHALL KOHLER, ITS COMPONENT SUPPLIERS NOR THE SELLING DEALER BE LIABLE FOR ANY DELAY, WORK STOPPAGE, LOSS OF USE OF EQUIPMENT, LOSS OF TIME, INCONVENIENCE, LOSS OF PROFITS, OR ANY INDIRECT, INCIDENTAL, SPECIAL, OR CONSEQUENTIAL DAMAGES RESULTING FROM OR ATTRIBUTABLE TO, DEFECTS IN KOHLER PRODUCTS OR SERVICE, WHETHER RESULTING FROM NEGLIGENCE (INCLUDING GROSS NEGLIGENCE) OR OTHER TORT WARRANTY, CONTRACT, INDEMNITY, BREACH OF THE PROMISE TO REPAIR OR REPLACE CONTAINED HEREIN, STRICT LIABILITY OR OTHERWISE.

IN ADDITION, KOHLER, ITS COMPONENT SUPPLIERS AND THE SELLING DEALER SHALL NOT BE LIABLE IN TORT OR STRICT LIABILITY FOR ANY ECONOMIC LOSS RESULTING, IN WHOLE OR IN PART, FROM THE MANUFACTURE OR SUPPLY OF THE PRODUCT, PARTS, COMPONENTS AND/OR LABOR.

NOTWITHSTANDING ANYTHING IN THIS WARRANTY TO THE CONTRARY, THE MAXIMUM LIABILITY, IF ANY, OF KOHLER, ITS COMPONENT SUPPLIERS AND THE SELLING DEALER FOR ALL DIRECT DAMAGES SHALL NOT EXCEED THE PRICE OF THE PARTICULAR DEFECTIVE PRODUCT, PART OR SERVICE, AS APPLICABLE.

THE STANDARD WARRANTY, THE EMISSION CONTROL WARRANTIES, AND THE EXTENDED LIMITED MACHINE AND POWERTRAIN WARRANTIES, IF APPLICABLE, ARE THE ONLY WARRANTIES APPLICABLE TO KOHLER PRODUCTS AND COMPONENTS USED IN KOHLER PRODUCTS AND ARE EXPRESSLY IN LIEU OF ANY WARRANTIES OR CONDITIONS OTHERWISE IMPLIED BY LAW (INCLUDING ANY WARRANTY OTHERWISE IMPLIED BY LAW FOR THE PRODUCT BY THE MANUFACTURER OR ITS COMPONENT SUPPLIERS), INCLUDING, BUT NOT LIMITED TO, IMPLIED WARRANTIES OF MERCHANTABILITY OR FITNESS FOR A PARTICULAR PURPOSE AND IS NOT A WARRANTY OF FUTURE PERFORMANCE.

THE REMEDIES UNDER THIS WARRANTY SHALL BE THE ONLY REMEDIES AVAILABLE TO THE OWNER OF KOHLER PRODUCTS OR ANY OTHER PERSON, AND NEITHER KOHLER NOR THE SELLING DEALER ASSUMES ANY OTHER OBLIGATION OR RESPONSIBILITY WITH RESPECT TO THE CONDITION OF KOHLER PRODUCTS, AND AUTHORIZES NO OTHER PERSON TO ASSUME FOR ANY OF THEM, ANY OTHER OBLIGATION OR LIABILITY.

Kohler reserves the right to make changes in design or add any improvements on its products at any time without incurring any obligation to install same on units previously delivered.

If the original owner sells the engine and machine, the remaining period of this warranty shall be transferred to the new owner.

“Kohler” means both Kohler Co. and its Affiliates, d/b/a Kohler Power Systems.

Kohler request that each owner of the engine and machine complete and provide the following requested information, sign in the space indicated, retain a completed and signed copy of this statement for the owner’s records, and return a completed and signed copy of this statement to Kohler. Failure to complete, sign, or return this form will not affect any owner’s rights or Kohler’s obligations under this warranty statement and will not result in denial of warranty coverage by Kohler.

MODEL: _____	PIN (Prod. Id. No.): _____
NAME OF DEALER _____	NAME OF OWNER _____
SIGNATURE OF AUTHORIZED REPRESENTATIVE OF DEALER _____	SIGNATURE OF AUTHORIZED REPRESENTATIVE OF OWNER _____
CITY / STATE / ZIP CODE OF DEALER _____	CITY / STATE / ZIP CODE OF OWNER _____
DATE MACHINE PLACED INTO SERVICE _____	

This Emission Control Warranty Statement is applicable to KD18L06, KD27V12, KD36V16, KD45V20, KD62V12, KD83V16 and KD103V20 engines.

Preface

Only for the United States of America:

▲ WARNING: This product can expose you to chemical substances, including carbon monoxide and benzene, which are known to the State of California to cause cancer, birth defects and reproductive harm.
Additional information at <https://www.p65warnings.ca.gov/>.

▲ WARNING: Inhaling diesel engine exhaust exposes you to chemical substances, which are known to the State of California to cause cancer, birth defects and reproductive harm.

- Engines may only be started and operated in well ventilated areas.
- In closed rooms, the exhaust must be discharged into the open air.
- The exhaust system may not be changed or manipulated.
- Only let the engine run at an idle when it is necessary.

Additional information at <https://www.p65warnings.ca.gov/>.

This operation and maintenance manual has been written for the **operator** and **maintenance personnel** of the engine.

It contains descriptions for:

- Technical data
- Safety regulations
- Handling and operation
- Maintenance

The operation and maintenance manual is to be carefully read and applied before the first commissioning and later at regular time intervals by each person who is assigned to work with / on the engine.

Work with or on the engine is, for example:

- **Operation**
- **Servicing**, including maintenance, inspection

This facilitates familiarization with the engine for the operator and prevents malfunctions due to improper handling.

Kohler Co. will not accept any warranty claims that arise due to improper handling, insufficient maintenance, use of unapproved fuel and operating fluids, or failure to observe the safety regulations.

Kohler Co. will cancel all possible obligations undertaken by Kohler Co. and/or its dealers, such as guarantee commitments, service agreements etc., without prior notice if parts other than original Kohler Co. parts or spare parts purchased from Kohler Co. are used for maintenance and repair.

Under extreme conditions, more frequent maintenance than scheduled in the maintenance and inspection schedule can be required.





Compliance

This chapter is valid for Tier 2 and Tier 4 certified engines.

According to US regulation 40 CFR Part 1039 and 1068 (§1039.125 and §1068.110), the owner may choose any qualified workshop to properly service, replace or repair emission-related components with original parts or equivalent spare parts. The owner is obligated to have warranty and recall services that are paid for by Kohler performed by an authorized Kohler dealer/service center.

This operator's manual contains the legally required information for end users according to US regulation 40 CFR Part 1039 and 1068.

Graphic icons used in these instructions

Icon	Meaning
	Note Indicates useful information and tips.
	Prerequisite Indicates conditions for subsequent action steps.
	Call to action Indicates action steps.
	Result Indicates results of one or more action steps.
-	List Indicates individual points of a list.

Graphic icons

Changes, conditions, copyright

This document is protected by copyright. The copyright holder is:

– Kohler Co.

Subject to change in the interest of technical progress.

ISO 16016 protection notice: “Transmission and duplication of this document, utilization and communication of its contents are prohibited, unless expressly permitted. Infringements will lead to compensation. All rights reserved in the event of patent, utility model or design registration.”

For further information, contact your nearest authorized Kohler customer service.

List of changes

Version	From serial number	Comment	Date
33521029401_1_1	2016 16 0001	First version	December 2016
33521029401_2_1	2016 16 0001	Various amendments	April 2017
33521029401_3_1	2016 16 0001	Change of maintenance schedule	August 2017
33521029401_4_1	2016 16 0001	Various amendments	August 2018
33521029401_5_1	2016 16 0001	Corrections	November 2018
33521029401_6_1	2016 16 0001	Maintenance schedule updated (exhaust aftertreatment system maintenance activities integrated). Service chapter removed. Warranty statement for emission control integrated.	March 2021
33521029501_7_1	2016 16 0001	Change of the graphics in the chapter "Design overview". Change of the graphics in the chapter "Overview of sensors". Addition to "Low-load operation" information in the chapter "Starting the engine". Update of "Operating fluids and maintenance" chapter. Integration of EATS in the approved fuel qualities. Addition to description "Paraffinic fuels (according to EN15940). Addition to HVO table. Correction to "Minimum requirement for quality" table. Structural adjustment of "Maintenance" chapter. Addition to "Definition of service levels" chapter. Update of maintenance schedule. Update of "Tightening torques" chapter.	September 2022

Version	From serial number	Comment	Date
33521029401_8_1	2016 16 0001	Update of maintenance schedule Checking the exhaust system chapter – SL1-5201 added Checking the exhaust gas turbocharger chapter – SL1-5411 added Replacing the fan drive bearing maintenance interval – SL2-7212 added	December 2023

List of changes

Contents

1	Product description	17
1.1	Technical description	17
1.1.1	Engine components	17
1.1.2	Overview of sensors	19
1.1.3	Engine type itemization	19
1.1.4	Company nameplate	20
1.1.5	Engine control unit nameplate	21
1.2	Technical data	23
1.2.1	Engine	23
1.2.2	Cylinder head	23
1.2.3	Coolant thermostat	23
1.2.4	Battery charging alternator	24
1.2.5	Starter	24
1.2.6	Flywheel housing	24
2	Safety	26
2.1	Identification of the warnings	26
2.2	Additional markings	26
2.3	Target audience	27
2.3.1	International standard classification of occupations	27
2.3.2	Occupational references	27
2.3.3	Unauthorized personnel	28
2.4	Intended use	28
2.5	Foreseeable misuse	29
2.6	General safety instructions	30
2.7	Preventing personal injuries	31
2.7.1	Crushing	31
2.7.2	Burns and scalds	31
2.7.3	Fires and explosions	31

2.7.4	Poisoning	31
2.7.5	High pressure injection (ejection of liquids under high pressure)	32
2.7.6	Electrical energy	32
2.7.7	Danger due to noise	32
2.8	Personal protective equipment	32
2.9	Operating areas and maintenance areas	33
2.9.1	Safety instructions	33
2.9.2	Operating areas	34
2.9.3	Maintenance areas	34
2.9.4	Securing the engine against unexpected start-up and releasing it	35
2.9.5	Emergency stop	36
2.10	Signage	36
2.11	Preventing property damage	37
3	Handling, operation	38
3.1	Filling the operating fluids	38
3.2	Starting the engine	39
4	Operating faults	40
4.1	Errors – Cause – Remedy	40
5	Operating fluids and maintenance	46
5.1	Lubricants and operating materials	46
5.1.1	Fill quantities	46
5.1.2	Diesel fuels	46
5.1.3	Engine oils	48
5.1.4	Coolant	51
5.1.5	Diesel exhaust fluid (DEF)	52
5.2	Maintenance schedule	53
5.2.1	Nominal values of the power generator	53
5.2.2	Definition of service levels	53
5.2.3	Maintenance schedule – TIER 0-2 Service Level 0	55
5.2.4	Maintenance schedule – TIER 4 Service Level 0	57
5.2.5	Maintenance schedule – TIER 0-2 ESP Service Level 1	60
5.2.6	Maintenance schedule – TIER 4 ESP Service Level 1	62

5.2.7	Maintenance schedule – TIER 0-2 ESP Service Level 2	65
5.2.8	Maintenance schedule – TIER 4 ESP Service Level 2	67
5.2.9	Maintenance schedule – TIER 0-2 PRP Service Level 1	68
5.2.10	Maintenance schedule – TIER 4 PRP Service Level 1	70
5.2.11	Maintenance schedule – TIER 0-2 PRP Service Level 2	71
5.2.12	Maintenance schedule – TIER 4 PRP Service Level 2	72
5.2.13	Maintenance schedule – TIER 0-2 COP Service Level 1	73
5.2.14	Maintenance schedule – TIER 4 COP Service Level 1	75
5.2.15	Maintenance schedule – TIER 0-2 COP Service Level 2	76
5.2.16	Maintenance schedule – TIER 4 COP Service Level 2	77
5.3	Preliminary work	79
5.3.1	Bringing the engine into maintenance position	79
5.4	1000 - Engine	80
5.4.1	Visual inspection (tightness, damage, loose parts) – SLO-1011	80
5.4.2	Observing the engine when idling – SLO-1021	83
5.4.3	Observing the engine in operation (only emergency power system - ESP application) – SLO-1022	83
5.4.4	Checking/setting the valve clearance – SL1-1122	84
5.4.5	Replacing the crankcase breather system oil separator filter – SL1-1661	84
5.4.6	Replacing the crankcase breather system V-ribbed belt – SL1-1662	87
5.5	2000 - Lubrication system	95
5.5.1	Checking the oil level – SLO-2011	95
5.5.2	Changing the lubricating oil – SL1-2020	96
5.5.3	Taking an oil sample and performing an oil analysis – SL1-2021	98
5.5.4	Replacing the oil filter – SL1-2110	100
5.6	3000 - Cooling system	102
5.6.1	Checking the coolant level – SLO-3011	102
5.6.2	Replacing the coolant – SL1-3020	102
5.6.3	Taking a coolant sample and performing a coolant analysis – SL1-3021	102
5.6.4	Checking and replacing the belt drive for the coolant pump and battery charging alternator – SL1-3281	104
5.7	4000 - Fuel system	108
5.7.1	Checking the fuel level and checking / draining the water separator on the primary fuel filter – SLO-4011	108
5.7.2	Replacing the fuel prefilter – SL1-4110	108

5.7.3	Replacing the main fuel filter – SL1-4120	108
5.8	5000 - Exhaust system and charge air system	111
5.8.1	Checking the exhaust system – SL1-5201	111
5.8.2	Checking the exhaust gas aftertreatment system – SLO-5302	111
5.8.3	Replacing the diesel exhaust fluid filter – SL1-5320	112
5.8.4	Checking the exhaust gas turbocharger – SL1-5411	117
5.9	7000 - Accessories	118
5.9.1	Checking the fan drive belt drive – SL1-7221	118
6	Transport and storage	120
6.1	Transport	121
6.1.1	Transport attachment	121
6.1.2	Wood transport device	122
6.2	Storage	123
6.2.1	Storage for up to 6 months	123
6.2.2	Storage for over 6 and up to 24 months	123
7	Tools and devices	124
7.1	Tools	124
7.1.1	Special tools for maintenance tasks	124
8	Standard torques	126
8.1	Tightening torques	126
8.1.1	Hex head screws / hexagon socket screws / hexalobular flange head screws	126
8.1.2	High temperature screws	127
8.1.3	Screw plugs and banjo bolts with separate seal	128
8.1.4	VSTI screw plugs	129
8.1.5	Threaded union for steel or cast iron mating materials	129
8.1.6	Threaded union for aluminum mating material	131
8.1.7	Nut for cutting ring screw fittings	132
8.1.8	Nut for Triple Lok [®] screw fittings	133
8.1.9	Threaded union for plastic quick couplings	134
8.1.10	Stud bolts	134
8.1.11	Pipe clamp on fuel lines	135
8.1.12	Hose clamp	136

8.1.13	V-band clamp on charge air pipes and rubber connections	137
8.1.14	V-band clamp with seal or o-ring	137
8.2	Error code	138

Contents

1 Product description

1.1 Technical description

1.1.1 Engine components

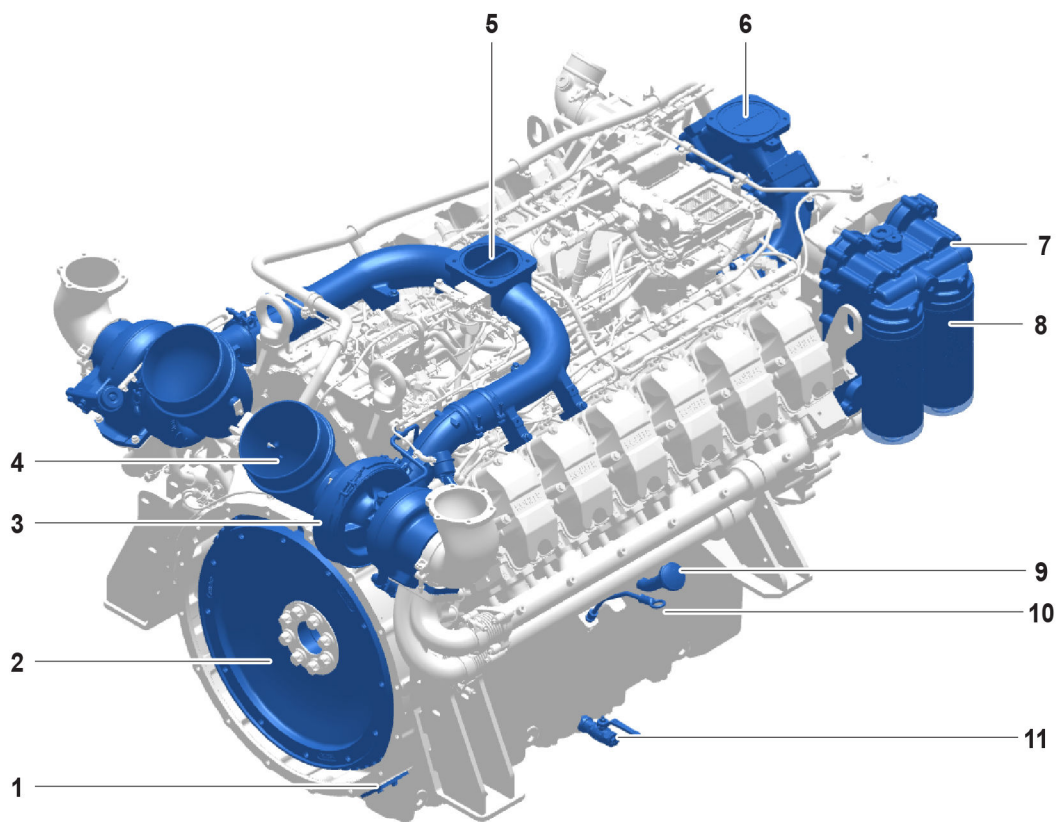

Fig. 1: Driving end engine components

- | | | | |
|----------|-------------------------------------|-----------|----------------------|
| 1 | Fastening point for turning device | 7 | Oil module |
| 2 | Flywheel | 8 | Oil filter |
| 3 | Exhaust gas turbocharger | 9 | Oil filler neck |
| 4 | Intake pipe | 10 | Oil dipstick |
| 5 | Air outlet to the charge air cooler | 11 | Oil drain stop valve |
| 6 | Air inlet from charge air cooler | | |

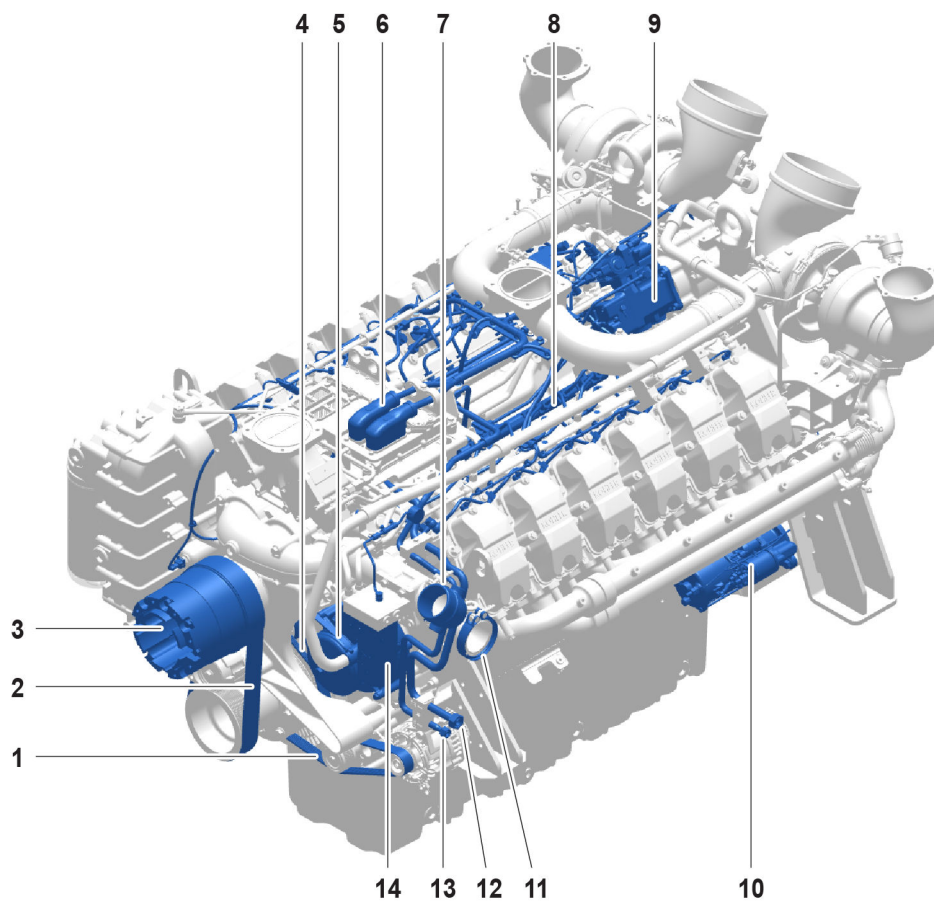

Fig. 2: Free end engine components

- | | | | |
|----------|--|-----------|-------------------------|
| 1 | V-ribbed belt for battery charging alternator and coolant pump | 8 | Fuel rail (2x) |
| 2 | Fan drive V-ribbed belt | 9 | Fuel high pressure pump |
| 3 | Fan drive | 10 | Starter motor |
| 4 | Crankcase breather system V-ribbed belt | 11 | Coolant inlet |
| 5 | Crankcase breather system | 12 | Fuel supply |
| 6 | Engine control unit | 13 | Fuel return |
| 7 | Coolant outlet | 14 | Main fuel filter |

1.1.2 Overview of sensors

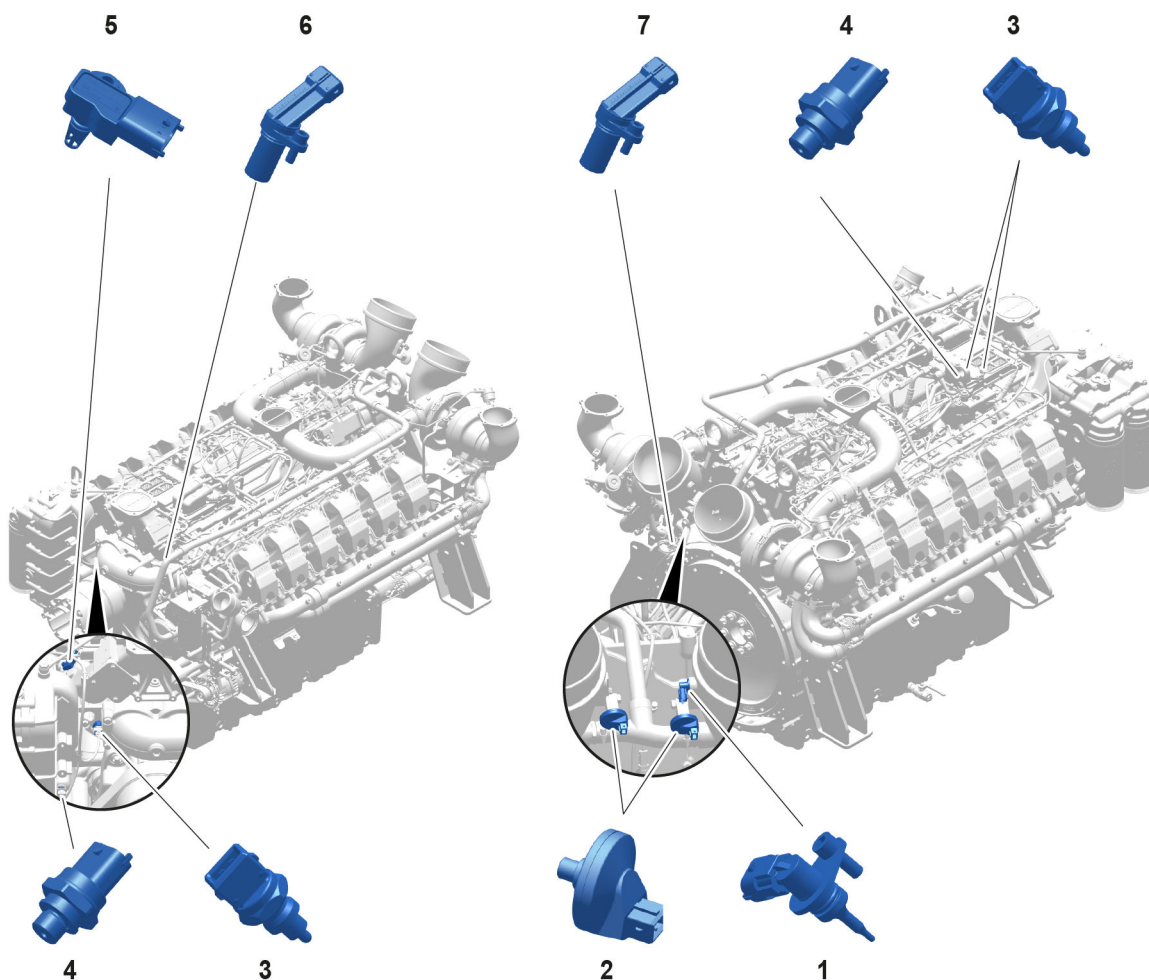

Fig. 3: Overview of sensors

- | | |
|--|---|
| <p>1 Temperature sensor</p> <p>2 Charge air pressure & temperature sensor maintenance switch (2x)</p> <p>3 Temperature sensor</p> <p>4 Pressure sensor</p> | <p>5 Pressure & temperature sensor</p> <p>6 Speed sensor</p> <p>7 Speed sensor</p> |
|--|---|

1.1.3 Engine type itemization

Engine type designation									
K	D	27	V	12	5	A	F	C	Description
K									Manufacturer
	D								Engine
		27							Total displacement: 27 l
			V						V-engine
				12					Number of cylinders
					5				Frequency: 5 = 50 Hz; 6 = 60 Hz

Engine type designation									
K	D	27	V	12	5	A	F	C	Description
						A			Power group: A, wherein A is the smallest power group and E is the largest power group.
							F		Optimization: F = Fuel optimization; E = Exhaust optimization
								C	Application: C = COP; P = Prime; S = Standby; D = Data center

Tab. 1: Engine type designation

1.1.4 Company nameplate

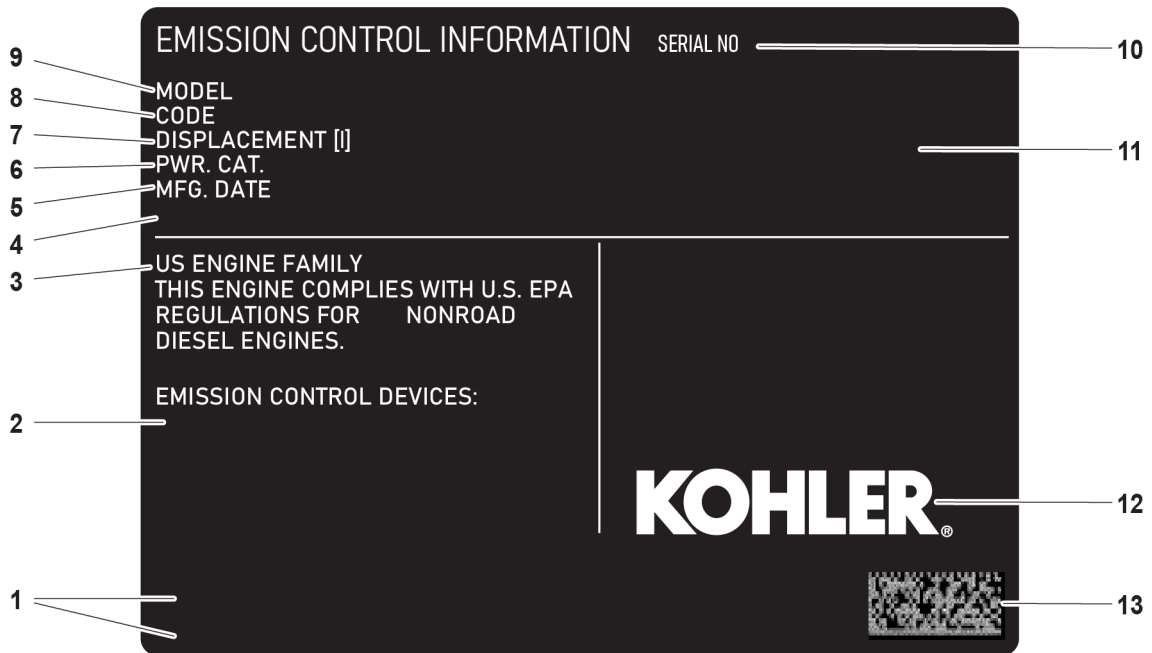

Fig. 4: Company nameplate

- | | | | |
|---|-------------------------------|----|--------------------------------|
| 1 | Intended use | 8 | Engine variant (internal type) |
| 2 | Emission control devices | 9 | Engine type |
| 3 | US type approval information | 10 | Engine serial number |
| 4 | Minimum requirements for fuel | 11 | EU exemption (optional) |
| 5 | Date of manufacture | 12 | Manufacturer |
| 6 | US performance category | 13 | Data matrix code |
| 7 | Displacement | | |

Itemization of engine serial numbers

The engine serial number is engraved on the company nameplate in the field SERIAL NO..

Engine serial number		
Year of manufacture	Type designation or nominal size designation	Sequential production number
2019	16	0001

Tab. 2: Engine serial number (example)

Type designation or nominal size designation	Engine type
16	KD27V12

Tab. 3: Designation of the type designation or nominal size designation

1.1.5 Engine control unit nameplate

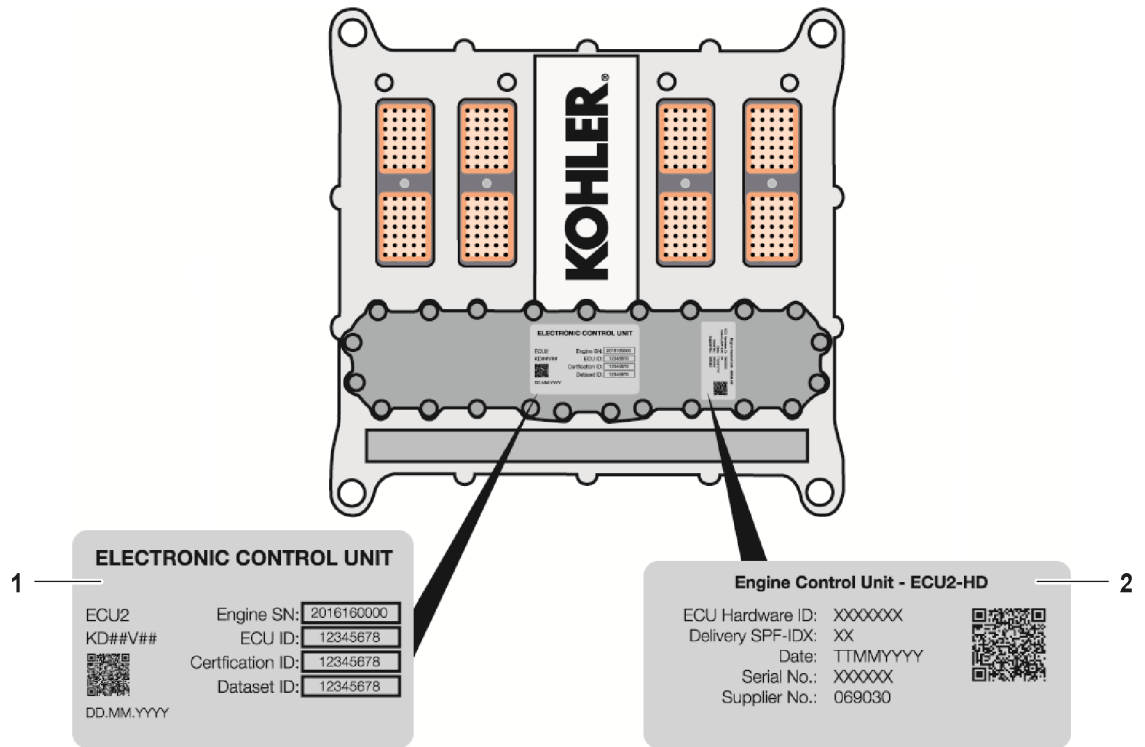

Fig. 5: Position of the engine control unit nameplate

- 1 Software company name plate
- 2 Hardware company name plate

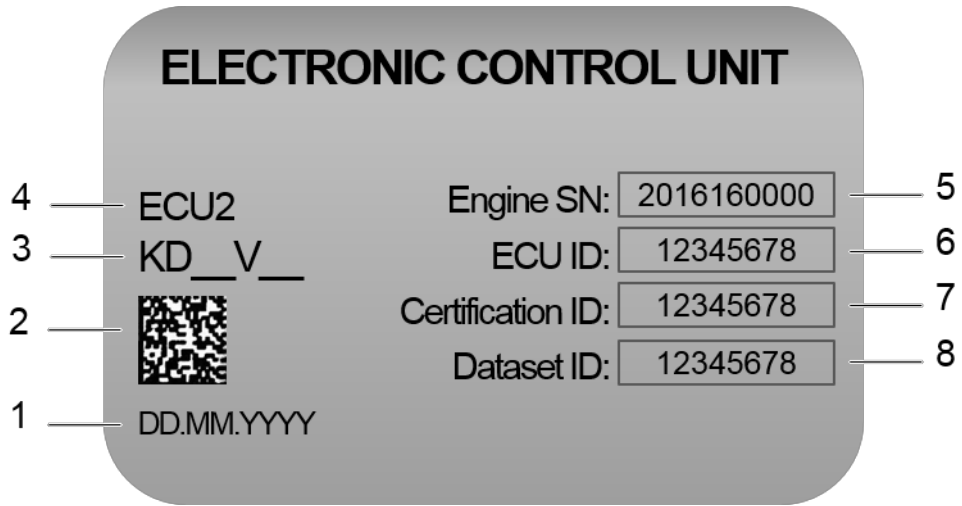

Fig. 6: Example of an engine control unit nameplate

- | | |
|---|---|
| <p>1 Delivery date</p> <p>2 Data matrix code</p> <p>3 Engine type</p> <p>4 Control unit description</p> | <p>5 Engine serial number</p> <p>6 Control unit serial number</p> <p>7 ID number certification</p> <p>8 ID number parameter set</p> |
|---|---|



Information

The information on the engine control unit nameplate corresponds to the delivery condition. Depending on the software updates in the field, this information may no longer be current. The actual information can be called up on the device display or read out with the KODIA diagnostics and service tool.

1.2 Technical data

1.2.1 Engine

Name	Unit	Value
Construction		V-engine
Number of cylinders		12
Firing order		1-12-2-11-3-10-6-7-5-8-4-9
Firing order according to ISO 1204		B6-A1-B5-A2-B4-A3-B1-A6-B2-A5-B3-A4
Bore	mm in	135 5.31
Stroke	mm in	157 6.18
Displacement	l gal	26.967 7.1239
Compression ratio		15: 1
Direction of rotation of the engine (viewed from the flywheel)		counterclockwise
Power rating according to		ISO 3046-1
Rated power		See company nameplate
Rated speed		See company nameplate
Emission limit value stage		See company name plate

Tab. 4: Technical data - Engine

1.2.2 Cylinder head

Name	Unit	Value
Inlet valve clearance, cold	mm in	0.5 0019
Outlet valve clearance, cold	mm in	0.6 0023

Tab. 5: Cylinder head

1.2.3 Coolant thermostat

Name	Unit	Value
Start of opening	°C	82
	°F	179
Completely opened	°C	92
	°F	197

Tab. 6: Coolant thermostat

1.2.4 Battery charging alternator

Description	Unit	Value
Voltage	V	28
Current	A	140

1.2.5 Starter

Description	Unit	Value
Voltage	V	24
Output per start system	kW	7.8

1.2.6 Flywheel housing

Description	Unit	Value
Connection		SAE 0

2 Safety



2.1 Identification of the warnings

	This is a warning sign. It warns you of the risk of possible injury. Follow all of the instructions that accompany this warning sign to avoid any injuries or death.
---	--

Tab. 7

This warning sign only appears in conjunction with the signal words:

DANGER
WARNING
CAUTION

	DANGER	indicates a hazardous situation which, if not avoided, will result in death or serious injury.
	WARNING	indicates a hazardous situation which, if not avoided, could result in death or serious injury.
	CAUTION	indicates a hazardous situation which, if not avoided, could result in minor or moderate injury.
	NOTICE	indicates a hazardous situation which, if not avoided, could result in material damages.

Tab. 8

2.2 Additional markings

	Information	indicates useful information and tips.
---	--------------------	--

Tab. 9

2.3 Target audience

Level 1 – Basic maintenance	Level 2 – Advanced maintenance
Daily checks, inspection and maintenance tasks which can be carried out in intervals between operation without dismantling parts from engine. For example: oil and fuel refilling	Maintenance work that requires partial dismantling of the engine on site (service after half the service life). For example: replacing pumps, injection valves, heads etc.
By the customer or the nearest authorized Kohler service representative.	By the customer or the nearest authorized Kohler service representative.

Tab. 10



Information

The machine's manufacturer is responsible for:

- ▶ Checking the personnel's know-how and skills
- ▶ Defining the necessary additional, refresher and further qualifications
- ▶ Defining the responsibilities and authorizations
- ▶ Applying ILO - "C138 - Minimum Age Convention 1973" with a minimum age for the work permit of 14 years.
- ▶ Providing the necessary tools and spare parts

2.3.1 International standard classification of occupations

In accordance with the International Standard Classification of Occupations (ISCO-08) of the International Labor Office (ILO), the following unit groups are listed as references to define the target audiences, occupations and joint tasks.

2.3.2 Occupational references

The occupations listed perform the following work in accordance with the "General safety instructions" chapter:

- The main tasks described in this manual or these instructions
- The tasks identified as requirements to prepare the main tasks

For the SL1 maintenance of power generation engines:

Maintenance Technician

In relation to ILO – Power Plant or Industrial Machinery Mechanics – unit group 7233 / ISCED-97 level 2.

The work on engines, equipment as well as mechanical and electronic equipment includes:

- Operating the machine and facilities
- Performance of scheduled maintenance work
- Assembly, installation, assessment, adjustment, testing and maintenance
- Location of defects
- Recording the repair and maintenance work performed

For the SL2 maintenance of power generation engines:

Technician

In relation to ILO – Power Plant or Industrial Machinery Mechanics – unit group 7233 / ISCED-97 on at least one level, from 3 to 4).

The work on engines, equipment as well as mechanical and electronic equipment includes:

- Operating the machine and facilities
- Performance of scheduled maintenance work
- Assembly, installation, assessment, adjustment, testing and maintenance
- Location of defects
- Dismantling and reassembly of the machine as well as the mechanical and electronic equipment
- Ensuring compliance with standards and specifications
- Recording the repair and maintenance work performed

2.3.3 Unauthorized personnel

All other persons, including operators, supervisors and trainees, are classified as "unauthorized personnel" for maintenance work.

They are not allowed to service the engine or access the engine compartment or engine cover.

For the operation of power generation engines:

Operator

In relation to ILO – Power Production Plant Operators – unit group 3131 / ISCED-97 on at least one level, from 2 to 4)

Power production plant operators operate, monitor and maintain switchboards and related equipment in electrical control centers which control the production and distribution of electrical or other power in transmission networks. The work includes:

- Operating, monitoring and inspecting various types of energy-generating power plants
- Operating and controlling power-generating systems and equipment
- Controlling start-up and shut-down of power plant equipment
- Controlling switching operations, regulating water levels
- Communicating with systems operators to regulate and coordinate transmission loads, frequency and line voltages
- Taking readings from charts, meters and gages at established intervals, troubleshooting and performing corrective action as necessary
- Completing and maintaining station records, logs and reports, and communicating with other plant personnel to assess the equipment operating status
- Cleaning and maintaining equipment such as the battery charging alternator, pumps or compressors in order to prevent defects or damage to the equipment

2.4 Intended use

Only operate the engine within the intended load range.

Only operate the engine in the device within the test range (NTE range) for the corresponding engine category.

- Use the engine for the intended purpose.

- Limited intended purposes, see company nameplate (→ [1.1.4 Company nameplate, p. 20](#)).
- Observe the following conditions from the manufacturer:
 - Operating conditions
 - Maintenance conditions
 - Servicing conditions
- Ensure that the following activities are only performed by persons according to the target group definition:
 - Use engine.
 - Maintain engine.
 - Service engine.

(→ [2.3 Target audience, p. 27](#))

- Install contactors and protective devices prior to commissioning and ensure their function.
- Observe safety instructions and operating instructions.
- Operate the engine in flawless condition.
- Operate the engine in the speed range prescribed by the manufacturer.
- Screw the engine with the attached engine brackets to the machine or to the respective operation site with the respective tightening instructions provided by the customer.
- Have engine brackets that were not installed by the manufacturer approved by the manufacturer.
- Only operate the engine in areas that are not publicly accessible.
- Only operate the engine with an enclosure or engine compartment cover.

2.5 Foreseeable misuse

These instructions have been prepared according to the applicable standards and regulations and according to the state of the art.

Kohler Co. assumes no liability for:

- Disregarding the instructions
- Improper use
- Use of personnel that does not meet the requirements according to the target group.
- Changes and conversions to the engine which were carried out without approval from Kohler.
- Use of operating fluids and auxiliary materials that are not approved by Kohler
- Use of spare parts that are not approved by Kohler, including any damages arising as a result
- Circumventing and disregarding safety regulations
- Disregarding international and national regulations for occupational safety
- Disregarding international and national regulations for environmental protection
- Unauthorized changes to the engine
- Manipulation to the injection system and control system
- Emergency operation with limited safety function is deemed improper use. The manufacturer is not liable for damages due to improper use.

EU type approval expires for:

- Manipulation to the engine
- Manipulation to the injection system and control system
- Manipulation to the exhaust aftertreatment system

The actual scope of delivery of the engine can differ from the relevant information in these instructions due to situational adaptations to customer requirements.

2.6 General safety instructions

- Fulfill the requirements of the target audiences for the work ([→ 2.3 Target audience, p. 27](#)).
- In order to guarantee help in the event of an accident:
 - A second person is present.
 - Ensure that the emergency situation will be detected and help will take place.
- Ensure that the personnel is familiar with this manual before installation work.
- Only allow the following personnel to work on the engine under the constant supervision and responsibility of a technician in accordance with the target group definition.
 - Personnel to be trained
 - Personnel to be taught
 - Personnel to be instructed
 - Personnel in apprenticeships[\(→ 2.3 Target audience, p. 27\)](#)
- Check the safety and hazard-conscious work of the personnel under the following conditions:
 - Observe the accident prevention regulations.
 - Observe the generally recognized safety and occupational health rules.
 - Observe the manual.
- Make sure that the personnel wear the prescribed work clothing ([→ 2.8 Personal protective equipment, p. 32](#)).
- Do not wear the following:
 - Rings
 - Wristwatches
 - Neckties
 - Scarves
 - Open jackets
 - Loose-fitting clothing
- Make sure that the following equipment is available for the assembly, clean, complete and undamaged:
 - Basic tool kit
 - Required devices
 - Required special tools
- Replace damaged tools.
- Keep the workplace clean and orderly.
- Make preparations for emergencies that could occur.
- Have a fire extinguisher and first aid kit ready.
- Have emergency telephone numbers available.
- Make sure that the workplace has sufficient lighting.
- Perform installation work only when the engine is secured.
- Ensure that the engine is not started by unauthorized individuals.

2.7 Preventing personal injuries

2.7.1 Crushing

- Do not lift heavy parts by hand.
- Fasten and simultaneously secure individual parts and larger assemblies carefully to lifting device during the replacement.
- Use Kohler lifting gear. Use Kohler lifting gear according to the operation and maintenance manual.
- Comply with the provisions for lifting points.
- Only use undamaged load handling attachments.
- Only use load handling attachments with sufficient load bearing capacity.
- Make sure that no persons reside under loads.
- When the engine is running, objects can be flung back: Make sure that no objects come in contact with moving parts.

2.7.2 Burns and scalds

The engine at operating temperature is hot:

- Only work on the cooled down engine.
- Touch hot parts with thermal protection gloves for repair purposes.

Before work on the cooling system:

- Let engine cool down.
- Release the pressure in the cooling system on the device side.
- Avoid contact with parts carrying coolant.

When the engine is at operating temperature, the engine oil is hot:

- Avoid skin contact with hot engine oil or parts carrying oil.

2.7.3 Fires and explosions

- Smoking is prohibited in the immediate vicinity of the engine.
- Avoid fires, sparks and open flames when handling fuels and flammable liquids.
- Start the engine according to the provisions of the repair instructions and assembly instructions.
- Eliminate leaks and replace damaged parts.
- When working on batteries: Put on safety goggles and safety gloves.
- After maintenance and repair work, remove and clean residues of operating fluids (for example: engine oils, lubricating greases, fuel, coolant).
- Remove rags that are soaked with flammable liquids.
- When working on the electrical system: Disconnect the electrical power supply.

2.7.4 Poisoning

- Only allow the engine to run in closed rooms when there is sufficient ventilation.
- Never ingest operating fluids.
- Do not use beverage bottles to store operating fluids.

Escaping liquids can penetrate the skin and will lead to blood poisoning:

- Do not open any lines and hoses that are under pressure.
- Do not remove any lines and hoses that are under pressure.
- Protect hands, face and body against escaping liquids when searching for leaks on lines and hoses that are under pressure ([→ 2.8 Personal protective equipment, p. 32](#)).

2.7.5 High pressure injection (ejection of liquids under high pressure)

When the engine is running, the fuel lines are constantly under a fuel pressure of up to 2400 bar.

Only work on the fuel system and injection system when the engine is turned off:

- Wait at least 20 minutes before starting work so that the pressure in the injection system has been relieved.
- Check pressure reduction with the diagnostic program (let drop below 20 bar).
- Use suitable protective equipment when working on the fuel and injection system (for example, protective gloves, safety goggles etc.).
- Do not open any fuel lines and fuel hoses that are under pressure.
- Do not pull out fuel lines and fuel hoses that are under pressure.
- When searching for leaks, do not palpate fuel lines and fuel hoses that are under pressure with your hands.
- Bring the engine into a clean area of the workshop, in which no work is being performed that will cause dust to be dispersed (grinding, welding work, brake repairs, brake and power tests etc.).

2.7.6 Electrical energy

- People with pacemakers have no access to the safety zones around the operational engine.
- Do not touch live parts.
- Before work on the electrical system, disconnect the power supply and secure it against being switched back on.

2.7.7 Danger due to noise

Possible permanent hearing loss due to noise levels above 84 dB(A). Sound levels up to 110 dB(A) possible!

- Keep all sound-insulating protective devices for the system closed when the engine is running.
- Only reside near the running engine with hearing protection matched to the noise level.
- Observe the hearing protection measures according to the repair instructions of the device manufacturer.

Access to the safety zones is prohibited for the operator and unauthorized personnel when the engine is ready for operation or in operation.

2.8 Personal protective equipment

- Wear protective equipment for direct access to engines.
- Make sure that:
 - Protective equipment is in good condition.
 - Protective function is guaranteed.

The following protective equipment is required to access the engine:

Use protective clothing

- Tight-fitting protective clothing that is not tear-resistant to protect against injuries and simple chemical substances



Wear protective work clothing in the immediate vicinity of the engine.



Use head protection

- Protection against
 - Falling or flying object
 - Bumping your head

Wear a safety helmet in the immediate vicinity of the engine.



Use foot protection

- Foot protection against
 - Falling objects
 - Pinching of the foot in heavy parts
 - Against slipping

Wear safety shoes in the immediate vicinity of the engine.



Use hand protection

- Protection against hot elements and chemicals

Wear safety gloves when working with hot parts, for example,

- shrinking the gear ring onto the flywheel.
- Working with operating fluids (See manufacturer's specifications for the operating fluids and safety data sheet for the operating fluid.)



Use eye protection

- Protection against:
 - Flying fragments
 - Chemical splashes
- Wear safety goggles when:
 - Handling operating fluids (See manufacturer's specifications for the operating fluids and safety data sheet for the operating fluid.)
 - Wear during mechanical interventions, for example, using compressed air.



Use hearing protection

- Protection against noise
 - Wear hearing protection around the diesel engine when it is running.



Use a mask

- Protection against breathing in harmful substances

2.9 Operating areas and maintenance areas

2.9.1 Safety instructions

Trapping points and mechanical parts flying around when the engine is ready for operation or in operation.

Serious injuries and risk of death:

- Keep away from the operational engine.
- Wear personal protective equipment.
- Technicians may reside in safety zone "A" for measurement purposes, if nothing else has been stated by the device manufacturer.

Hot parts when the engine is ready for operation or in operation.

Risk of burns:

- Keep away from the operational engine.
- Wear personal protective equipment.
- Let the engine cool down sufficiently.

High electric short-circuit currents during maintenance work

Risk of burns from electric shock:

- Access to safety zones in maintenance condition, according to target group definition
- Disconnect the electrical power supply.
- Wear personal protective equipment.

2.9.2 Operating areas

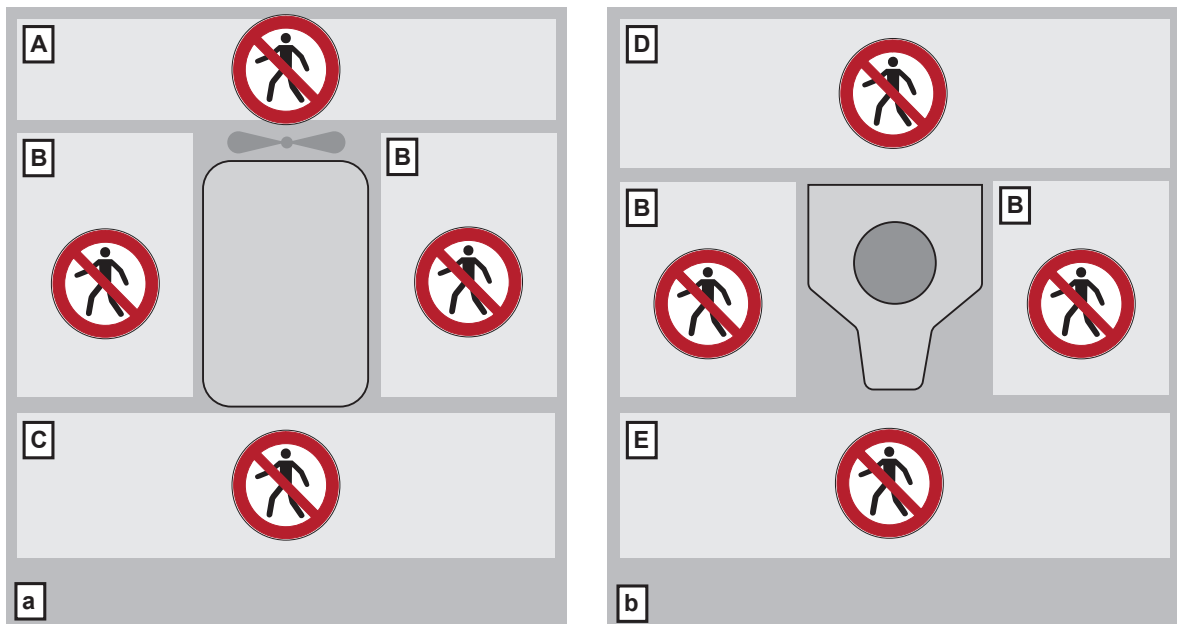

Fig. 19: Safety zones for the engine that is ready for operation or in operation

a Horizontal plan (view from above)

b Vertical plan (view from driving end)

Do not enter the following zones:

- Safety zone for free end **A**
- Safety zone next to the engine **B**
- Safety zone for driving end **C**
- Safety zone above the engine **D**
- Safety zone below the engine **E**

2.9.3 Maintenance areas

Maintenance areas are the safety zones that are to be entered for maintenance work and troubleshooting.



WARNING

Hot components!
Serious burns possible.

- ▶ Let the engine cool down to below 50 °C.
- ▶ Wear heat-resistant safety gloves.
- ▶ Wear heat-resistant work attire.

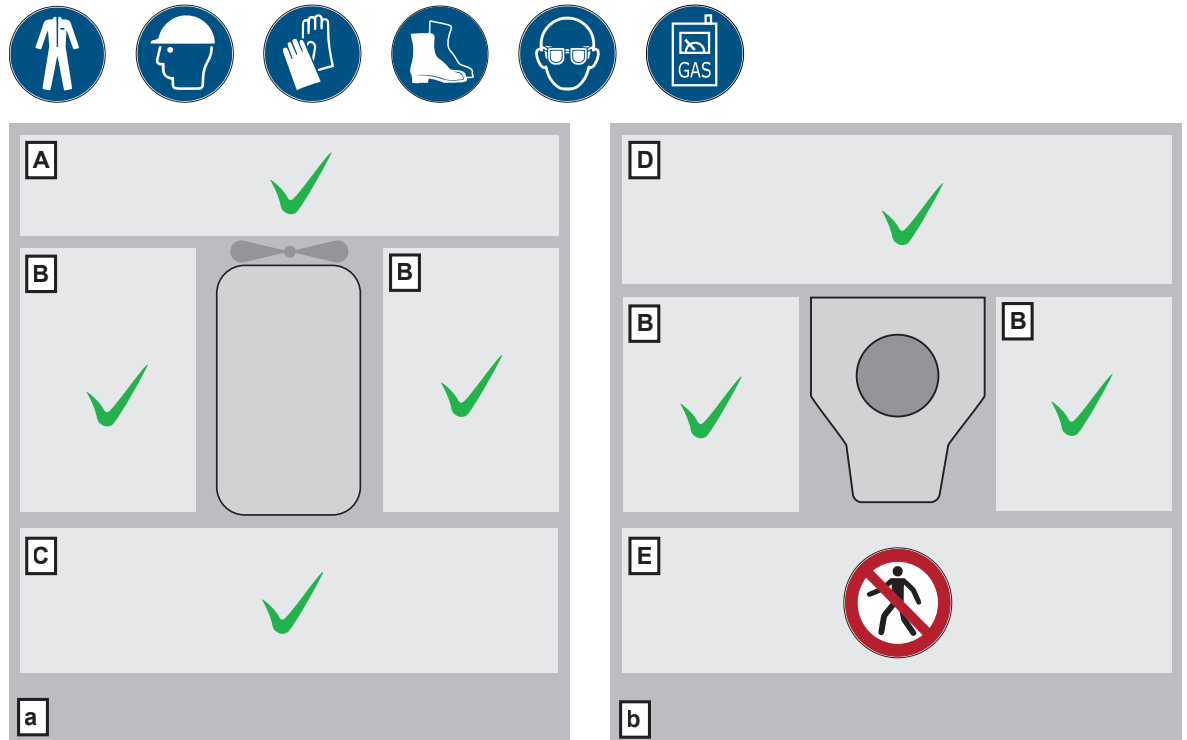

Fig. 20: Safety zones for maintenance and repairs

a Horizontal plan (view from above)

b Vertical plan (view from driving end)

The following zones are accessible:

- Safety zone for free end **A**
- Safety zone next to the engine **B**
- Safety zone for driving end **C**
- Safety zone above the engine **D**

Do not enter the following zones:

- Safety zone below the engine **E**

2.9.4 Securing the engine against unexpected start-up and releasing it

Secure the engine against unexpected start-up before entering the safety zones.

Procedure:

Secure the engine against unexpected start-up:

- Disconnect the diesel fuel supply.
- Mark the cut-off point with a tag.
- Disconnect the power supply and secure it against being switched back on.
- Mark the cut-off point with a tag.

Make the engine operational (release it):

- The following activities have been completed:
 - Installation activities
 - Maintenance activities
 - Repair activities
- All foreign objects are removed.
- All protective devices are installed and are functioning.
- No outsiders are residing in the danger zones.
- The tags for the fuel supply are removed.
- Fuel supply is connected.
- The tag for the power supply is removed.

- The power supply is established.

2.9.5 Emergency stop

An emergency stop is available for hazardous situations which require an immediate shutdown of the engine. The power supply to the engine is interrupted immediately. The engine control unit continues to have power.

Examples of hazardous situations:

- Fire
- Person suffers an electric shock
- Engine will not stop
- Engine accelerates uncontrollably

Only actuate the emergency stop in emergency situations. Actuating the emergency stop can permanently damage the engine. The emergency stop may not be used for an operational stop of the engine.

2.10 Signage



Information

- ▶ Make sure that signs are attached so they are clearly visible and are in the immediate vicinity of the safety zones.
 - ▶ Make sure that signs withstand the environmental conditions.
 - ▶ Make sure that signs remain visible and legible during the entire life cycle.
 - ▶ Additional warning symbols or adaptations to product standards (ISO 8528-13) are possible.
-



ISO 7010 / W012 Warning against dangerous electrical voltage:

- Work in the designated area is only permitted by personnel who know the dangers of electricity.
Unauthorized individuals are only permitted in the safety zone if the electrical power supply is disconnected.



ISO 7010 / W017 Warning against hot surfaces:

- There are hot surfaces on the engine which are not immediately apparent.
Wait a sufficient cooling time.
Touch any potentially hot components using suitable protective gloves.



ISO 7010 / W025 Warning of entanglement hazard:

- Possible trapping points exist on the engine in the area of the poly-v-belt and the alternator for battery charging.
Attach a warning sign if trapping points are not secured by protective devices (optional).
Enter safety zone only after engine is turned off.
Secure the engine against unexpected start-up.



ISO 7010 / P007 No access for people with pacemakers or implanted defibrillators:

- Possible EMC radiation, which can affect pacemakers and implanted defibrillators.



ISO 7010 / M002 Observe instructions:

- Make sure that personnel are aware of all residual risks.
Ensure that all residual risks according to the risk assessment of the device manufacturer are reflected in the system documentation.
Make sure that system documentation is read and understood.
Make documentation available to the personnel without restrictions according to the "target audience" (→ [2.3 Target audience](#), p. 27).

2.11 Preventing property damage

Preventing property damage:

- Replace sealing material, for example, o-rings and seals.
- Check removed parts for reusability, see corresponding information in the repair instructions.
- Replace removed, not reusable parts.
- If no specific tightening torques and tightening instructions are specified: Tighten screwed assemblies according to the standard tightening torques (→ [8.1 Tightening torques](#), p. 126).
- Replace self-locking screwed assemblies.
- Thoroughly clean the engine, connections and screwed assemblies of engine oil, combustion residues or care products before installation.
- Use lint-free cleaning cloths.
- Do not touch electrical contacts. Connection will be affected by contamination or components will be destroyed by electrostatic discharge.
- Before cleaning the engine: Cover or tape up openings to prevent coolant, steam or cleaning agent from entering.
- Remove covers or adhesives after cleaning.
- Check gas-conveying lines, engine oil lines and hydraulic lines for the following defects:
 - Leaks
 - Loose connections
 - Abrasion points
 - Damage
- Make sure that the electrical power supply is securely connected when starting.
- Before disconnecting the electrical power supply: Turn off engine.
- Use suitable test leads for measurements on plug connections.
- If no mating connector is attached: Protect the engine control unit against dust and coolant.
- When working on the electrical system: Disconnect the battery (if present).
- Disconnect the negative pole first and connect it last.
- During electric welding on the machine, remove the plug from the control unit.

3 Handling, operation

3.1 Filling the operating fluids

Fill the following operating fluids before the initial commissioning:

- **Lubricating oil**
Use suitable lubricating oil for the engine. ([→ 5.1.3 Engine oils, p. 48](#))
- **Coolant**
Observe coolant composition. ([→ 5.1.4 Coolant, p. 51](#))
- **Diesel fuel**
Diesel fuels must comply with the approved fuel specifications. ([→ 5.1.2 Diesel fuels, p. 46](#))

After the operating fluids are filled, perform the following work:

- ▶ Ventilate fuel system, see documentation for the generator set.

3.2 Starting the engine

Make sure that the following prerequisites are met:

- Oil level is OK.
- Coolant is filled.
- Charge air is connected.
- Exhaust gas disposal is ensured.
- The electrical power supply is ready.
- Fuel supply is connected.



WARNING

Unexpected movement of the equipment!
Can cause serious injuries or the death of persons.

- ▶ Make sure that no one is in the safety zones of the engine.
 - ▶ Move all protective devices into protective position (enclosure, if present, is closed).
 - ▶ Secure external parts against unexpected movements. Remove all persons from the danger zones.
-



Information

Engine damage due to insufficient lubrication!

- ▶ The oil pressure must build up immediately after starting the engine (oil pressure warning light goes out).
-



Information

Low load duration

Kohler Diesel engines have been approved for running at low loads. Operating the engine at low loads for extended periods of time can increase deposits/carbon buildup (Intensified at low ambient temperature).

This can be detrimental to the longevity and compliance of the engine.

If your operating profile has a prolonged low load duration, it is necessary to contact your genset supplier to take the necessary precautions.

If all of the safety instructions in the “Safety” chapter have been taken into account:

- ▶ Switch on the electrical power supply (battery voltage).

Final check

After successful engine start, perform the following checks and, if necessary, refill operating fluids.

- ▶ Check the oil level.
- ▶ Check the coolant level.
- ▶ Perform a visual check for any leaks in the lines.
- ▶ Check for KODIA error messages.
- ▶ Check for generator sets' error messages.

4 Operating faults

See Faults - Cause - Remedy table for engine problems and corrective measures. ([→ 4.1 Errors – Cause – Remedy, p. 40](#))



Information

- ▶ Engine errors are shown on the diagnosis and service tool as an error code for diagnostic purposes.
- ▶ The electronic control unit has an error memory. Error entries are stored in the error memory. The remedy for the errors is described in the device documentation.

The following are available for error identification:

- Warning lights in the device display
- Diagnostics software

4.1 Errors – Cause – Remedy

Malfunction / error	Cause	Remedy
Starter motor does not turn.	Main fuse is blown.	Replace the fuse.
	Battery connections are loose or corroded.	Clean and tighten the loose connections.
	Battery voltage is too low.	Charge or replace the battery.
	Starter circuit is defective or the contacts are corroded.	Contact your nearest authorized Kohler service representative. See "Service Assistance" section.
	Starter is defective.	Contact your nearest authorized Kohler service representative. See "Service Assistance" section.
Starter motor turns slowly.	Battery voltage is too low.	Charge or replace the battery.
	Battery connections are loose or corroded.	Clean and tighten the loose connections.
	Outside temperature is too low.	Take appropriate action for Winter operation.

Malfunction / error	Cause	Remedy
Engine will not start and/or stops again immediately.	Fuel tank is empty.	Refuel and vent the fuel system.
	Main fuel filter is clogged.	Replace the fuel filter.
	Fuel line, pre-cleaner or sieve in fuel tank is clogged.	Clean and vent the fuel system.
	Fuel system or filter is leaking.	Seal and ventilate.
	Outside temperature is too low.	Take appropriate action for winter operation.
Engine is difficult to start.	There is a leak in the low-pressure circuit or the pressure is too low.	Carry out a leak test (visual inspection). Contact your nearest authorized Kohler service representative to have the engine checked. See "Service Assistance" section.
	Compression of the engine is too low.	Contact your nearest authorized Kohler service representative. See "Service Assistance" section.
	Fault in the electronics.	Read out the error memory of the engine control unit. Contact your nearest authorized Kohler service representative. See "Service Assistance" section.
Engine suddenly switches off.	Voltage supply was interrupted.	Contact your nearest authorized Kohler service representative. See "Service Assistance" section.
	There is a leak in the low-pressure circuit or the pressure is too low.	Carry out a leak test (visual inspection). Contact your nearest authorized Kohler service representative to have the engine checked. See "Service Assistance" section.
	Fault in the electronics.	Read out the error memory of the engine control unit. Contact your nearest authorized Kohler service representative. See "Service Assistance" section.

Operating faults

Errors – Cause – Remedy

Malfunction / error	Cause	Remedy
Power of the engine is too low (lack of power).	There is a fault in the fuel system (blockage, leak).	Carry out a visual inspection for leaks, replace the filter. Contact your nearest authorized Kohler service representative. See "Service Assistance" section.
	Charging pressure is too low.	V-band clamps are loose, seals and hoses are defective, air filter is contaminated, exhaust gas turbo-charger defective. Contact your nearest Kohler customer service. See "Service" section.
	Charge air temperature is too high.	Charge air cooler is contaminated, fan power is reduced, ambient temperature is too high. Contact your nearest Kohler customer service. See "Service" section.
	Coolant temperature is too high.	Check the cooler for soiling, check the fan and thermostat, check the coolant level. Contact your nearest authorized Kohler service representative. See "Service Assistance" section.
	Fuel temperature is too high.	Contact your nearest authorized Kohler service representative. See "Service Assistance" section.
	Injectors are defective or do not vaporize.	Contact your nearest authorized Kohler service representative. See "Service Assistance" section.
	Compression of the engine is too low.	Contact your nearest authorized Kohler service representative. See "Service Assistance" section.
	Fault in the electronics.	Read the error logs of the engine control unit. Contact your nearest authorized Kohler service representative. See "Service Assistance" section.
Engine is too hot (according to coolant temperature display).	Coolant level is too low.	Fill up with coolant.
	Cooler is contaminated or calcified.	Clean or decalcify cooler. Contact your nearest Kohler customer service. See "Service" section.
	Thermostat has a fault.	Check this and replace if necessary. Contact your nearest authorized Kohler service representative. See "Service Assistance" section.

Malfunction / error	Cause	Remedy
Charging current display illuminates when engine is running.	Tension of the V-ribbed belt is insufficient.	Check the tension of the V-ribbed belt and replace the tightening roller if necessary.
	V-ribbed belt is worn.	Replace the V-ribbed belt.
	Cable connections are loose or disconnected.	Fasten or replace the cable.
	Battery charging alternator, rectifier or regulator is defective.	Contact your nearest authorized Kohler service representative. See "Service Assistance" section.
Black smoke is coming out of the engine.	Injectors are defective or inefficient.	Contact your nearest authorized Kohler service representative. See "Service Assistance" section.
	Exhaust gas turbocharger has a fault (too low charging pressure).	Contact your nearest authorized Kohler service representative. See "Service Assistance" section.
	Engine is overloaded.	Contact your nearest authorized Kohler service representative. See "Service Assistance" section.
Exhaust gases are blue.	Oil level in engine is too high.	Check and correct the oil level.
	Lubricant enters the combustion chamber and is burnt.	Contact your nearest authorized Kohler service representative. See "Service Assistance" section.
	Bearing seal on exhaust gas turbocharger is defective.	Contact your nearest authorized Kohler service representative. See "Service Assistance" section.
	Ventilation of the crankcase is defective.	Check this and replace if necessary.
Exhaust gases are white.	Injection starts too late.	Contact your nearest authorized Kohler service representative. See "Service Assistance" section.
	Operating temperature is not reached.	Run the engine until it reaches its operating temperature.
	Water in the fuel system.	Check the fuel system and the drain pre-filter.
	Charge air cooler has a leak.	Contact your nearest authorized Kohler service representative. See "Service Assistance" section.

Operating faults

Errors – Cause – Remedy

Malfunction / error	Cause	Remedy
Engine knocks.	Fault during combustion.	Contact your nearest authorized Kohler service representative. See "Service Assistance" section.
	Error in valve clearance.	Adjust the valve clearance.
	Injectors are damaged or carbonized.	Contact your nearest authorized Kohler service representative. See "Service Assistance" section.
	Bearing damages.	Contact your nearest authorized Kohler service representative. See "Service Assistance" section.
	Piston rings are worn or defective, pistons are eroded.	Contact your nearest authorized Kohler service representative. See "Service Assistance" section.
Abnormal noises.	Intake lines and exhaust pipes are leaking, causing a whistling noise.	Seal the leaks and replace the gaskets if necessary.
	Turbine or compressor wheel is rubbing on the housing; foreign objects have entered into the compressor or turbine; bearings may have seized.	Contact your nearest authorized Kohler service representative. See "Service Assistance" section.
Engine oil pressure is too low.	Oil level in oil pan is too low.	Fill oil to prescribed mark.
	Lubricating oil is too thin (oil diluted by diesel fuel).	Drain the oil and refill with the specified oil.
	Pressure sensor has a fault.	Check the oil pressure and replace the damaged pressure transducer. Contact your nearest authorized Kohler service representative. See "Service Assistance" section.
	Pressure control valve does not work correctly or is contaminated.	Contact your nearest authorized Kohler service representative. See "Service Assistance" section.
Engine oil is in the cooling system.	Oil cooler or oil cooler plate is leaking.	Contact your nearest authorized Kohler service representative. See "Service Assistance" section.
Coolant is in the engine oil.	Cylinder gaskets are leaking.	Contact your nearest authorized Kohler service representative. See "Service Assistance" section.
	Oil cooler or oil cooler plate is leaking.	Contact your nearest authorized Kohler service representative. See "Service Assistance" section.
Charge air temperature is too high.	Charge air cooler is contaminated.	Contact your nearest authorized Kohler service representative. See "Service Assistance" section.
	Air inlet temperature is too high.	Check the fan, air supply and breather.

Malfunction / error	Cause	Remedy
Charge air pressure is too low.	Air filter is clogged.	Check the air filter's service display, if equipped.
	Charge air cooler is contaminated.	Contact your nearest authorized Kohler service representative. See "Service Assistance" section.
	Exhaust gas turbocharger outlet is defective.	Contact your nearest authorized Kohler service representative. See "Service Assistance" section.

5 Operating fluids and maintenance

5.1 Lubricants and operating materials

5.1.1 Fill quantities

Name	Quantity
Lubricating oil	101 l (1.5 l per filter)
	26.68 US gal (0.4 US gal per filter)
Coolant	55 l
	14.5 US gal

Tab. 11: Fill quantities for oil change (reference values)

5.1.2 Diesel fuels

Approved fuel qualities

Due to different sulfur contents of these fuels, the lubricating oil change interval and quality must be taken into account during selection.

Fuel	Fuel quality	EATS 1)	Description
On-road diesel	ASTM D 975 1D-S15	•	HFFR < 460 µm
On-road diesel	ASTM D 975 1D-S500		HFFR < 460 µm without exhaust system
On-road diesel	ASTM D 975 1D-S5000		HFFR < 460 µm without exhaust system
On-road diesel	ASTM D 975 2D-S15	•	HFFR < 460 µm
On-road diesel	ASTM D 975 2D-S500		HFFR < 460 µm without exhaust system
On-road diesel	ASTM D 975 2D-S5000		HFFR < 460 µm without exhaust system
EU diesel	EN 590	•	Max. 7 % biodiesel content
Fuel oil	DIN 51603-1		Without exhaust system
Biodiesel	ASTM D97467		Biodiesel < 10 % ASTM D6751
GTL	DIN 15940		HFFR < 460 µm without exhaust system with additive S-1750
NATO fuel	NATO F-34		HFFR < 460 µm without exhaust system with additive S-1750

1) Exhaust aftertreatment system

Fuel	Fuel quality	EATS 1)	Description
NATO fuel	NATO F-35		HFFR < 460 µm without exhaust system
NATO fuel	NATO F-54	.	HFFR < 460 µm without exhaust system with additive S-1750
NATO fuel	NATO F-63		HFFR < 460 µm without exhaust system with additive S-1750
NATO fuel	XF-63		HFFR < 460 µm without exhaust system with additive S-1750
NATO fuel	XF-10		HFFR < 460 µm without exhaust system
NATO fuel	XF-51		HFFR < 460 µm max. 10% biodiesel
Aviation jet fuel	Jet A-1		HFFR < 460 µm without exhaust system with additive S-1750 without exhaust system
UK diesel	BS 2869 A2 and D	.	Max. 10 % biodiesel content without exhaust system

Tab. 12: Approved fuel qualities

Paraffinic fuels (according to EN 15940)

Paraffinic fuels (“synthetic diesel”) have a high cetane number and low density compared to diesel fuels. HVOs (Hydrotreated Vegetable Oils) are renewable. GTLs (Gas-To-Liquids) are fossil paraffinic fuels. The use of paraffinic fuels results in lower emissions, but also slightly higher fuel consumption and lower performance.

When using paraffinic diesel, a reduced filter change interval may be necessary due to the cleaning effect.

Rubber and elastomers in the fuel system can be affected when changing from diesel fuel to paraffinic fuel. Check daily whether fuel is leaking, and contact customer service for assistance if necessary.



Information

EN 15940 corresponds to ASTM D975 1D-15 and ASTM D975 2D-15 specifications.

Hydrogenated vegetable oil (HVO)

Standard fuel (standard)	Fuel quality (standard)	Required lubricating performance (maximum HFRR)	Additional required criteria	Compatible with EATS 2)	Change in performance / reduced maintenance interval
EN 15940	-	-	-	No	Yes 4) 3)

1) Exhaust aftertreatment system

2) Exhaust aftertreatment system

4) Rubber and elastomers in the fuel system can be affected when changing from diesel fuel to paraffinic fuel. Check daily whether fuel is leaking. If fuel is leaking, contact Kohler customer service. Fuel filter replacement interval shortens; rubber and elastomer parts must be monitored.

Standard fuel (standard)	Fuel quality (standard)	Required lubricating performance (maximum HFRR)	Additional required criteria	Compatible with EATS ²⁾	Change in performance / reduced maintenance interval
ASTM D975	-	-	-	No	Yes ^{4) 3)}

Tab. 13: Approved HVO fuels

Minimum requirement for quality

Specification	Parameter
Lubrication capability at 60 °C (HFRR)	460 µm
Minimum cetane number	45
Purity class according to ISO 4406 in the fuel tank	18/16/12
Purity class according to ISO 4406 after fuel fine filter	12/9/6

Tab. 14: Minimum requirement for diesel fuels



Information

Only operate Tier 2 and Tier 4 certified engines with sulfur-free fuel.

5.1.3 Engine oils

Performance requirements of the quality categories

Engine oil additives are not approved, since if they are incorrectly matched with the engine oil they may cause damage.

Engine oil category	Minimum standards	Recommended viscosity class	Engine oil type	Oil change factor
Engine oil Category 1	ACEA E5-02 or API CH-4 or DHD-1	SAE 10W-40; SAE 10W-30; SAE 15W-40	Mineral oil (Group 1 & 2 basic oils)	1/4
Engine oil Category 2	ACEA E4 ACEA E7 or API CI-4 Plus or DHD-1 or JASO DH-1	SAE 10W-40; SAE 10W-30; SAE 5W-30	Synthetic (Group 2 and / or 3 basic oils)	1

²⁾ Exhaust aftertreatment system

³⁾ The change interval of the fuel and fuel fine filter can be shortened.

⁴⁾ Rubber and elastomers in the fuel system can be affected when changing from diesel fuel to paraffinic fuel. Check daily whether fuel is leaking. If fuel is leaking, contact Kohler customer service. Fuel filter replacement interval shortens; rubber and elastomer parts must be monitored.

Engine oil category	Minimum standards	Recommended viscosity class	Engine oil type	Oil change factor
Engine oil Category 2.1	ACEA E6 or ACEA E9 or API CJ-4 or JASO DH-2	SAE 5W-30; SAE 10W-40; SAE 10W-30	Synthetic (Group 2 and / or 3 basic oils)	1
Engine oil Category 3 (standard today)	ACEA E4-12 or both ACEA E4 and ACEA E7	SAE 5W-30; SAE 10W-40; SAE 10W-30; SAE 5W-40	Synthetic (Group 3 and / or 4), VI > 160, and Longlife additive	2
Engine oil Category 3.1 (standard today)	ACEA E6-12 or both ACEA E6 and ACEA E9 or API CK-4	SAE 5W-30; SAE 10W-40; SAE 10W-30; SAE 5W-40	Synthetic (Group 3 and / or 4), VI > 160, and Longlife additive	2

Tab. 15: Engine oil category

Selecting the engine oil

Effect caused by the sulfur content in the fuel

The following table is intended to help select the right engine oil based on the total base number (TBN). This measurement value is important for reducing combustion gases that are greatly influenced by the sulfur content in the fuel.

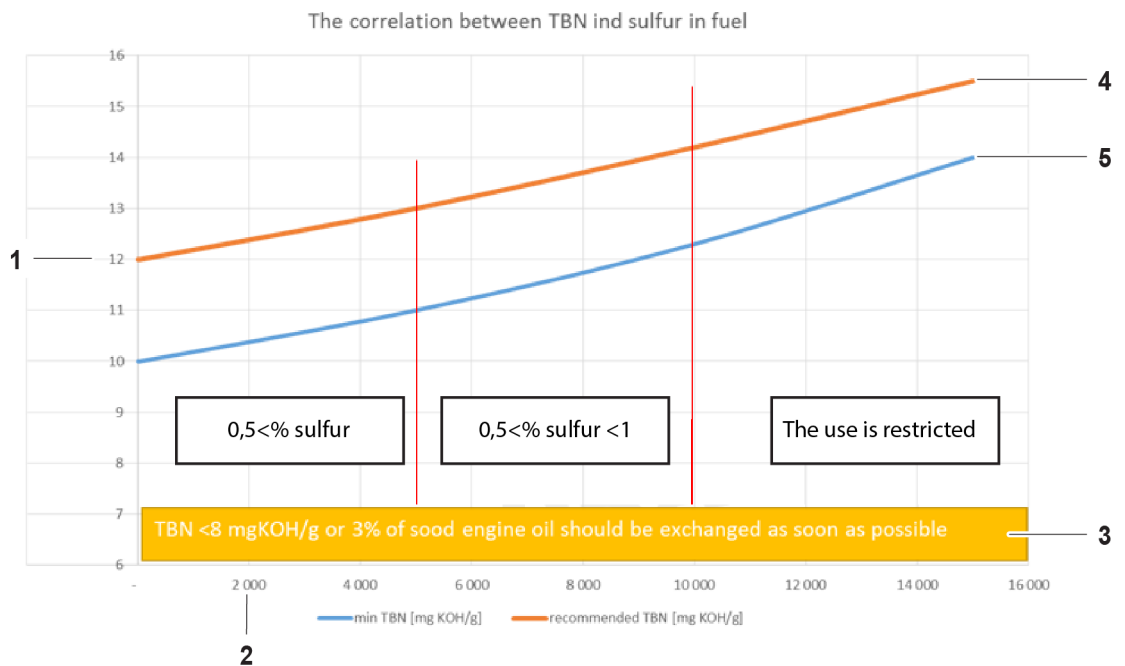

Fig. 26: The correlation between TBN and sulfur in fuel

- | | |
|--|---|
| <p>1 TBN</p> <p>2 ppm sulfur</p> <p>3 For TBN < 8 mgKOH/g (recommendation only for HA engine oils)</p> | <p>4 recommended TBN [mg KOH/g]</p> <p>5 minimum TBN [mg KOH/g]</p> |
|--|---|



Information

From small amounts of sulfur, only high-ash engine oils may be used. Changing the engine oil must be observed according to the specifications. The TBN curves shown are for informational purposes only and are not binding. The values do not apply to engine oils with a low ash content.

Viscosity class

The viscosity class must be selected based on the cold start temperature. The following viscosity classes are permitted for the engines: 5W30, 5W40, 10W30, 10W40 and 15W40. The change intervals according to the oil category must be observed.

Difficulty factors

Difficulty factors can be:

- Frequent cold starts
- Environmental influences
 - Operating temperature
 - Dust
 - High humidity
 - Long standstill times

If there are difficulty factors or difficult usage conditions, the oil change and filter change must be performed according to the following table.

Engine oil change intervals

The change intervals are defined as follows:

Basic oil change interval * Factor oil category * Factor sulfur content = change interval

The basic change interval is defined in the maintenance tables.

The basic change interval is defined in special maintenance tables according to the genset applications (ESP, PRP and COP) and engine injection calibration (EO or FO).

If there are difficulty factors or more difficult operating conditions, the oil change interval must be validated through an engine oil analysis.

Difficulty factors can be:

- Frequent cold starts
- Environmental influences
- Operating temperature
- Dust
- High humidity
- Long downtimes

Sulfur content in %	Oil change factor (factor 2)
0 < Sulfur content ≤ 0.5	"1" => no change of the maintenance interval
0.5 < Sulfur content ≤ 1 Limited to engine oil category 2 and 3	"1/2" => reduces the maintenance interval by half

Sulfur content in %	Oil change factor (factor 2)
1 < Sulfur content ≤ 1.5 Limited to engine oil category 2 and 3	“1/4” => reduces the maintenance interval by a quarter. The use of sulfur at ratios greater than 1% requires additional approval from engine manufacturers to ensure that all engine options, the engine oil used, and the maintenance schedule are compatible with this very high sulfur content. Special engine oil must be used => TBN > 12 MgKOH/g.

Tab. 16: Sulfur content table

Engine oil analysis

The engine oil can be monitored by means of an engine oil analysis and the change interval can be adjusted if required.

5.1.4 Coolant



Information

- Mixing different anticorrosion antifreeze agents can make the properties of the coolant worse.
- ▶ Do not combine different products!
 - ▶ Silicate-based and non-silicate based coolants must never be mixed; this may damage the cooling system!

Requirements for water

Make sure that the water used meets the following requirements:

- Fully de-ionized water should be used.
- Corresponds to the 2006 WHO (World Health Organization) guideline for drinking water.

The cooling circuit must remain within the following parameters:

- Hardness of water < 12 dH
- pH value 6.7 to 9.0
- Chloride and sulfate < 100 mg/l

Requirements of the coolant

Use only pre-mixed cooling water of the same kind to avoid problems with the cooling circuit.

An SI-OAT or hybrid technology with ethylene glycol is to be used as coolant, since this technology provides the necessary cooling performance and cooling function for engines.

Approved products:

- BASF GLYSANTIN® G40™ change interval 6 years
- BASF GLYSANTIN® G48™ change interval 4 years

The recommended coolant concentration is 40% to 50%.

The coolant can be monitored by means of a coolant analysis and the change interval can be adjusted if required. Control parameter for the coolant:

Analysis	Standard	Unit	Value
Visual appearance			Typical color, clear, normal smell, like new coolant
pH value	DIN EN ISO 10523:2012-04		6.7 – 9.0

Analysis	Standard	Unit	Value
Chloride		mg/l	< 100
Sulfate		mg/l	< 100
Bacteria and toxic components			without

Tab. 17: Control parameter

5.1.5 Diesel exhaust fluid (DEF)

In the SCR system (selective catalytic reduction), an aqueous urea solution is used as diesel exhaust fluid to reduce nitrogen oxide components (NO_x) in the exhaust gas. Approved diesel exhaust fluids are standardized according to ISO 22241 / DIN 70070.

DEF standard (standard)	DEF quality	Additional required criteria
ISO 22241 / DIN 70070	32.5 % diesel exhaust fluid by mass	Cleanliness according to ISO 4406 18/16/13 requires special filtration during tank filling.

Tab. 18: Specification to be observed

Common designations:

- AdBlue®
- DEF (diesel exhaust fluid)
- AUS 32 (aqueous urea solution)

5.2 Maintenance schedule

Using the maintenance schedule

The time intervals during which a component can remain in operation between two maintenance operations are divided as follows:

Interval is the operating time in hours.

Limit interval is the maximum operating time in years.

A maintenance activity is performed as soon as an interval (operating hours or period) is reached. The first interval that occurs applies.

5.2.1 Nominal values of the power generator

Power generators that fulfill the requirements of ISO 8528-1:2005 are used to produce electricity for continuous, peak load and standby applications. The classifications according to ISO 8528-1:2005 are intended to help improve the understanding between the manufacturer and customer.

Emergency power system (ESP)

The maximum available power during a variable power sequence under the specified operating conditions, which a power generator is capable of delivering in the event of a power failure or under test conditions for up to 200 hours of operation per year, wherein the maintenance intervals and work are executed in accordance with the manufacturer's instructions. The permissible average power output during 24 hours of operation should not exceed 85 percent of the ESP rating.

Main operating power (PRP)

The maximum power that a power generator is capable of delivering continuously for an unlimited number of hours per year under the agreed operating conditions with a variable electrical load, wherein the maintenance intervals and work are executed in accordance with the manufacturer's instructions. The permissible average power output during 24 hours of operation should not exceed 75 percent of the PRP rating.

Time between overhauls (TBO)

The designation for the average length of time until the engines are overhauled.

5.2.2 Definition of service levels



Information

The information on the engine company name plate corresponds to the delivery condition (ex works Kohler Co.). Based on the engine name, it can be determined which maintenance schedule must be used.

Preventive maintenance		Corrective maintenance
Level 0 & 1 – Basic maintenance	Level 2 – Extended maintenance	Troubleshooting and repair

Preventive maintenance		Corrective maintenance
Daily checks, inspections and maintenance measures that can be performed at operating intervals without removing engine parts. For example: Refilling lubricating oil and fuel	Maintenance measures, including partial disassembly of the engine on site (maintenance after half of the service life). For example: Replacement of the pump, injection, cylinder heads.	Repair work, such as the replacement of components to correct errors or malfunctions, including parts and labor
By the customer or authorized Kohler service representative	By an authorized Kohler service representative	By an authorized Kohler service representative

Tab. 19: Definition of service levels

The descriptions of the maintenance work are included in the following documents:

- Level 0 and 1 in this **operation and maintenance manual**
- Level 2 in the **service and repair manual**

Task designations

To facilitate orientation, the tasks are numbered according to the following conventions.

Itemization of task designations

Designation					Description	
SL2	-	1	2	3	4	Task code
SL2	-					Service level
		1				System (→ tab. 21, p. 54)
			2			Group (unit, cylinder head, etc.)
				3		Subgroup (injector, main fuel filter, etc.)
					4	Part (piston ring, o-ring, etc.)

Tab. 20: Itemization of task designations in the maintenance schedule

System directory

Designation	Description
1000	Engine
2000	Lubrication system
3000	Cooling system
4000	Fuel system
5000	Exhaust system
6000	Electrics and engine control unit
7000	Accessories

Tab. 21: System directory

5.2.3 Maintenance schedule – TIER 0-2 Service Level 0

ESP, ESP (TOP POWER) - Version: MS2023/09-24, MS2023/09-25

Activity identification	Component	Maintenance schedule		Maintenance activity		Description
		Operating hours (h)	Calendar interval (Day - Month - Year)	Check / clean	Replace	
SLO- 1011	Engine		1 month	X		The activity is performed before starting or when the engine is not running. Visual inspection (tightness, damages, loose parts). Identify and report anomalies.
SLO- 1021	Engine when idling		1 month	X		Inspect engine operation. Identify and report anomalies (tightness, incorrect parameters, unusual noises, vibrations, exhaust gas color).
SLO- 1022	Engine during operation		1 month	X		Test run at more than 1/3 load (if parameters are in range) and at least until steady-state temperature is reached. Identify and report anomalies (tightness, incorrect parameters, unusual noises, vibrations, exhaust gas color).
SLO- 2011	Engine oil		1 month	X		The activity is performed before starting or when the engine is not running. Check oil level. Refill if necessary. Take corrective measures if there is a defect.
SLO- 3011	Cooling system		1 month	X		The activity is performed before starting or when the engine is not running. Check coolant level. Refill if necessary. Check (including charge air cooler) drainage holes on air supply lines (free of deposits and coolant). Check drainage holes on NT and HT coolant pumps (free of oil and water).
SLO- 4011	Fuel system		1 month	X		The activity is performed before starting or when the engine is not running. Check fuel level. Refill if necessary. Check overall condition of engine fuel system. Check water separator on the primary fuel filter. Drain water if necessary. Replace prefilter insert if it is clogged or defective. Check differential pressure gauge of primary fuel filter / display for control monitoring (if present). Take corrective measures if there is a defect.

Activity identification	Component	Maintenance schedule		Maintenance activity		Description
		Operating hours (h)	Calendar interval (Day - Month - Year)	Check / clean	Replace	
SLO- 5011	Air filter		1 month	X		The activity is performed before starting or when the engine is not running. Replace air filter if necessary. If the air filter is clogged, damaged or improperly installed, inspect charge air pipe and exhaust gas turbo-charger.

Tab. 22: ESP, ESP (TOP POWER) - Version: MS2023/09-24, MS2023/09-25

PRP, COP - Version: MS2023/09-26, MS2023/09-27

Activity identification	Component	Maintenance schedule		Maintenance activity		Description
		Operating hours (h)	Calendar interval (Day - Month - Year)	Check / clean	Replace	
SLO- 1011	Engine		1 day	X		The activity is performed before starting or when the engine is not running. Visual inspection (tightness, damages, loose parts). Identify and report anomalies.
SLO- 1021	Engine when idling		1 day	X		Inspect engine operation. Identify and report anomalies (tightness, incorrect parameters, unusual noises, vibrations, exhaust gas color).
SLO- 2011	Engine oil		1 day	X		The activity is performed before starting or when the engine is not running. Check oil level. Refill if necessary. Take corrective measures if there is a defect.
SLO- 3011	Cooling system		1 day	X		The activity is performed before starting or when the engine is not running. Check coolant level. Refill if necessary. Check (including charge air cooler) drainage holes on air supply lines (free of deposits and coolant). Check drainage holes on NT and HT coolant pumps (free of oil and water).

Activity identification	Component	Maintenance schedule		Maintenance activity		Description
		Operating hours (h)	Calendar interval (Day - Month - Year)	Check / clean	Replace	
SLO- 4011	Fuel system		1 day	X		The activity is performed before starting or when the engine is not running. Check fuel level. Refill if necessary. Check overall condition of engine fuel system. Check water separator on the primary fuel filter. Drain water if necessary. Replace prefilter insert if it is clogged or defective. Check differential pressure gauge of primary fuel filter / display for control monitoring (if present). Take corrective measures if there is a defect.
SLO- 5011	Air filter		1 day	X		The activity is performed before starting or when the engine is not running. Replace air filter if necessary. If the air filter is clogged, damaged or improperly installed, inspect charge air pipe and exhaust gas turbo-charger.

Tab. 23: PRP, COP - Version: MS2023/09-26, MS2023/09-27

5.2.4 Maintenance schedule – TIER 4 Service Level 0

ESP, ESP (TOP POWER) - Version: MS2023/09-24, MS2023/09-25

Activity identification	Component	Maintenance schedule		Maintenance activity		Description
		Operating hours (h)	Calendar interval (Day - Month - Year)	Check / clean	Replace	
SLO- 1011	Engine		1 month	X		The activity is performed before starting or when the engine is not running. Visual inspection (tightness, damages, loose parts). Identify and report anomalies.
SLO- 1021	Engine when idling		1 month	X		Inspect engine operation. Identify and report anomalies (tightness, incorrect parameters, unusual noises, vibrations, exhaust gas color).

Activity identification	Component	Maintenance schedule		Maintenance activity		Description
		Operating hours (h)	Calendar interval (Day - Month - Year)	Check / clean	Replace	
SLO- 1022	Engine during operation		1 month	X		Test run at more than 1/3 load (if parameters are in range) and at least until steady-state temperature is reached. Identify and report anomalies (tightness, incorrect parameters, unusual noises, vibrations, exhaust gas color).
SLO- 2011	Engine oil		1 month	X		The activity is performed before starting or when the engine is not running. Check oil level. Refill if necessary. Take corrective measures if there is a defect.
SLO- 3011	Cooling system		1 month	X		The activity is performed before starting or when the engine is not running. Check coolant level. Refill if necessary. Check (including charge air cooler) drainage holes on air supply lines (free of deposits and coolant). Check drainage holes on NT and HT coolant pumps (free of oil and water).
SLO- 4011	Fuel system		1 month	X		The activity is performed before starting or when the engine is not running. Check fuel level. Refill if necessary. Check overall condition of engine fuel system. Check water separator on the primary fuel filter. Drain water if necessary. Replace prefilter insert if it is clogged or defective. Check differential pressure gauge of primary fuel filter / display for control monitoring (if present). Take corrective measures if there is a defect.
SLO- 5011	Air filter		1 month	X		The activity is performed before starting or when the engine is not running. Replace air filter if necessary. If the air filter is clogged, damaged or improperly installed, inspect charge air pipe and exhaust gas turbo-charger.
SLO- 5301	Exhaust aftertreatment system		1 month	X		Check of the exhaust aftertreatment system.
SLO- 5311	Diesel exhaust fluid (DEF)		1 month	X		Refill if necessary.

Tab. 24: ESP, ESP (TOP POWER) - Version: MS2023/09-24, MS2023/09-25

PRP, COP - Version: MS2023/09-26, MS2023/09-27

Activity identification	Component	Maintenance schedule		Maintenance activity		Description
		Operating hours (h)	Calendar interval (Day - Month - Year)	Check / clean	Replace	
SLO- 1011	Engine		1 day	X		The activity is performed before starting or when the engine is not running. Visual inspection (tightness, damages, loose parts). Identify and report anomalies.
SLO- 1021	Engine when idling		1 day	X		Inspect engine operation. Identify and report anomalies (tightness, incorrect parameters, unusual noises, vibrations, exhaust gas color).
SLO- 2011	Engine oil		1 day	X		The activity is performed before starting or when the engine is not running. Check oil level. Refill if necessary. Take corrective measures if there is a defect.
SLO- 3011	Cooling system		1 day	X		The activity is performed before starting or when the engine is not running. Check coolant level. Refill if necessary. Check (including charge air cooler) drainage holes on air supply lines (free of deposits and coolant). Check drainage holes on NT and HT coolant pumps (free of oil and water).
SLO- 4011	Fuel system		1 day	X		The activity is performed before starting or when the engine is not running. Check fuel level. Refill if necessary. Check overall condition of engine fuel system. Check water separator on the primary fuel filter. Drain water if necessary. Replace prefilter insert if it is clogged or defective. Check differential pressure gauge of primary fuel filter / display for control monitoring (if present). Take corrective measures if there is a defect.
SLO- 5011	Air filter		1 day	X		The activity is performed before starting or when the engine is not running. Replace air filter if necessary. If the air filter is clogged, damaged or improperly installed, inspect charge air pipe and exhaust gas turbo-charger.
SLO- 5301	Exhaust aftertreatment system		1 day	X		Check of the exhaust aftertreatment system.
SLO- 5311	Diesel exhaust fluid (DEF)		1 day	X		Refill if necessary.

Tab. 25: PRP, COP - Version: MS2023/09-26, MS2023/09-27

5.2.5 Maintenance schedule – TIER 0-2 ESP Service Level 1

ESP - Version: MS2023/09-24

Activity identification	Component	Maintenance schedule		Maintenance activity		Description
		Operating hours (h)	Calendar interval (Day - Month - Year)	Check / clean	Replace	
SL1- 1122	Valves	1000	4 years	X		“Check valve clearance and set if necessary; note: 1st check at 500h as suggested in the maintenance schedule.”
SL1- 1661	Crankcase breather system oil separator filter	2000	2 years		X	Replace oil separator filter.
SL1- 1662	Crankcase breather system poly-v-belt		2 years		X	Replace crankcase breather system poly-v-belt.
SL1- 2020	Engine oil	500	2 years		X	Change engine oil (oil category 2).
SL1- 2021	Oil analysis	250	1 year	X		Take oil sample. Perform oil analysis. Take recommended measures according to analysis results.
SL1- 2110	Oil filter	500	2 years		X	Replace oil filter. Clean engine side seal area before and after filter removal.
SL1- 3020	Coolant		4 years		X	Replace coolant.
SL1- 3021	Coolant analysis		1 year	X		Take a coolant sample. Perform coolant analysis. Take recommended measures according to analysis results.
SL1- 3281	Belt drive for coolant pump and battery charging alternator		1 year	X		Check belt, belt tensioning device and belt pulleys. Replace if a defect is present.
SL1- 4110	Primary fuel filter	1000	1 year		X	Replace primary fuel filter.
SL1- 4120	Fuel fine filter	1000	1 year		X	Replace fuel fine filter.
SL1- 5021	Air filter	3000	2 years	X		Check charge air pipe, tubes, hoses (also those for Wastegate / ventilation) and exhaust gas turbocharger (compressor blades, housing, connections, fastening). Take corrective measures if there is a defect.
SL1- 5201	Exhaust system		4 years	X		Check exhaust system.
SL1- 5411	Exhaust gas turbocharger		4 years	X		Check exhaust gas turbocharger.

Activity identification	Component	Maintenance schedule		Maintenance activity		Description
		Operating hours (h)	Calendar interval (Day - Month - Year)	Check / clean	Replace	
SL1- 7221	Fan drive belt drive		2 years	X		Check fan drive belt drive. Take corrective measures if there is a defect.

Tab. 26: ESP - Version: MS2023/09-24 – Service Level 1

ESP (TOP POWER) - Version: MS2023/09-25

Activity identification	Component	Maintenance schedule		Maintenance activity		Description
		Operating hours (h)	Calendar interval (Day - Month - Year)	Check / clean	Replace	
SL1- 1122	Valves	1000	4 years	X		“Check valve clearance and set if necessary; note: 1st check at 500h as suggested in the maintenance schedule.”
SL1- 1661	Crankcase breather system oil separator filter	2000	2 years		X	Replace oil separator filter.
SL1- 1662	Crankcase breather system poly-v-belt		2 years		X	Replace crankcase breather system poly-v-belt.
SL1- 2020	Engine oil	250	2 years		X	Change engine oil (oil category 2).
SL1- 2021	Oil analysis	250	1 year	X		Take oil sample. Perform oil analysis. Take recommended measures according to analysis results.
SL1- 2110	Oil filter	250	2 years		X	Replace oil filter. Clean engine side seal area before and after filter removal.
SL1- 3020	Coolant		4 years		X	Replace coolant.
SL1- 3021	Coolant analysis		1 year	X		Take a coolant sample. Perform coolant analysis. Take recommended measures according to analysis results.
SL1- 3281	Belt drive for coolant pump and battery charging alternator		1 year	X		Check belt, belt tensioning device and belt pulleys. Replace if a defect is present.

Activity identification	Component	Maintenance schedule		Maintenance activity		Description
		Operating hours (h)	Calendar interval (Day - Month - Year)	Check / clean	Replace	
SL1- 4110	Primary fuel filter	1000	1 year		X	Replace primary fuel filter.
SL1- 4120	Fuel fine filter	1000	1 year		X	Replace fuel fine filter.
SL1- 5021	Air filter	3000	2 years	X		Check charge air pipe, tubes, hoses (also those for Wastegate / ventilation) and exhaust gas turbocharger (compressor blades, housing, connections, fastening). Take corrective measures if there is a defect.
SL1- 5201	Exhaust system		4 years	X		Check exhaust system.
SL1- 5411	Exhaust gas turbocharger		4 years	X		Check exhaust gas turbocharger.
SL1- 7221	Fan drive belt drive		2 years	X		Check fan drive belt drive. Take corrective measures if there is a defect.

Tab. 27: ESP (TOP POWER) - Version: MS2023/09-25

5.2.6 Maintenance schedule – TIER 4 ESP Service Level 1

ESP - Version: MS2023/09-24

Activity identification	Component	Maintenance schedule		Maintenance activity		Description
		Operating hours (h)	Calendar interval (Day - Month - Year)	Check / clean	Replace	
SL1- 1122	Valves	1000	4 years	X		“Check valve clearance and set if necessary; note: 1st check at 500h as suggested in the maintenance schedule.”
SL1- 1661	Crankcase breather system oil separator filter	2000	2 years		X	Replace oil separator filter.
SL1- 1662	Crankcase breather system poly-v-belt		2 years		X	Replace crankcase breather system poly-v-belt.
SL1- 2020	Engine oil	500	2 years		X	Change engine oil (oil category 2).

Activity identification	Component	Maintenance schedule		Maintenance activity		Description
		Operating hours (h)	Calendar interval (Day - Month - Year)	Check / clean	Replace	
SL1- 2021	Oil analysis	250	1 year		X	Take oil sample. Perform oil analysis. Take recommended measures according to analysis results.
SL1- 2110	Oil filter	500	2 years		X	Replace oil filter. Clean engine side seal area before and after filter removal.
SL1- 3020	Coolant		4 years		X	Replace coolant.
SL1- 3021	Coolant analysis		1 year	X		Take a coolant sample. Perform coolant analysis. Take recommended measures according to analysis results.
SL1- 3281	Belt drive for coolant pump and battery charging alternator		1 year	X		Check belt, belt tensioning device and belt pulleys. Replace if a defect is present.
SL1- 4110	Primary fuel filter	1000	1 year		X	Replace primary fuel filter.
SL1- 4120	Fuel fine filter	1000	1 year		X	Replace fuel fine filter.
SL1- 5021	Air filter	3000	2 years	X		Check charge air pipe, tubes, hoses (also those for Wastegate / ventilation) and exhaust gas turbocharger (compressor blades, housing, connections, fastening). Take corrective measures if there is a defect.
SL1- 5201	Exhaust system		4 years	X		Check exhaust system.
SL1- 5310	Diesel exhaust fluid				X	Replace diesel exhaust fluid according to supplier documentation.
SL1- 5320	Diesel exhaust fluid filter	1500	6 months		X	Replace diesel exhaust fluid filter.
SL1- 5411	Exhaust gas turbocharger		4 years	X		Check exhaust gas turbocharger.
SL1- 7221	Fan drive belt drive		2 years	X		Check fan drive belt drive. Take corrective measures if there is a defect.

Tab. 28: ESP - Version: MS2023/09-24

ESP (TOP POWER) Version: MS2023/09-25

Activity identification	Component	Maintenance schedule		Maintenance activity		Description
		Operating hours (h)	Calendar interval (Day - Month - Year)	Check / clean	Replace	
SL1- 1122	Valves	1000	4 years	X		“Check valve clearance and set if necessary; note: 1st check at 500h as suggested in the maintenance schedule.”
SL1- 1661	Crankcase breather system oil separator filter	2000	2 years		X	Replace oil separator filter.
SL1- 1662	Crankcase breather system poly-v-belt		2 years		X	Replace crankcase breather system poly-v-belt.
SL1- 2020	Engine oil	250	2 years		X	Change engine oil (oil category 2).
SL1- 2021	Oil analysis	250	1 year	X		Take oil sample. Perform oil analysis. Take recommended measures according to analysis results.
SL1- 2110	Oil filter	250	2 years		X	Replace oil filter. Clean engine side seal area before and after filter removal.
SL1- 3020	Coolant		4 years		X	Replace coolant.
SL1- 3021	Coolant analysis		1 year	X		Take a coolant sample. Perform coolant analysis. Take recommended measures according to analysis results.
SL1- 3281	Belt drive for coolant pump and battery charging alternator		1 year	X		Check belt, belt tensioning device and belt pulleys. Replace if a defect is present.
SL1- 4110	Primary fuel filter	1000	1 year		X	Replace primary fuel filter.
SL1- 4120	Fuel fine filter	1000	1 year		X	Replace fuel fine filter.
SL1- 5021	Air filter	3000	2 years		X	Check charge air pipe, tubes, hoses (also those for Wastegate / ventilation) and exhaust gas turbocharger (compressor blades, housing, connections, fastening). Take corrective measures if there is a defect.
SL1- 5201	Exhaust system		4 years	X		Check exhaust system.
SL1- 5310	Diesel exhaust fluid				X	Replace diesel exhaust fluid according to supplier documentation.

Activity identification	Component	Maintenance schedule		Maintenance activity		Description
		Operating hours (h)	Calendar interval (Day - Month - Year)	Check / clean	Replace	
SL1- 5320	Diesel exhaust fluid filter	1500	6 months		X	Replace diesel exhaust fluid filter.
SL1- 5201	Exhaust system		4 years	X		Check exhaust system.
SL1- 7221	Fan drive belt drive		2 years	X		Check fan drive belt drive. Take corrective measures if there is a defect.

Tab. 29: ESP (TOP POWER) Version: MS2023/09-25

5.2.7 Maintenance schedule – TIER 0-2 ESP Service Level 2

ESP - Version: MS2023/09-24

Service Level 2 extended maintenance activities, see service and repair manual.

Activity identification	Component	Maintenance schedule		Maintenance activity		Description
		Operating hours (h)	Calendar interval (Day - Month - Year)	Check / clean	Replace	
SL2- 1211	Combustion chamber		8 years	X		Check combustion chambers. Take corrective measures if there is a defect.
SL2- 3210	Coolant pump		18 years		X	Replace coolant pump.
SL2- 4210	Injector(s)		8 years		X	Replace injector(s).
SL2- 4220	Fuel high pressure pump		18 years		X	Replace fuel high pressure pump
SL2- 5410	Exhaust gas turbocharger		18 years		X	Replace the exhaust gas turbocharger.
SL2- 7212	Fan drive bearing				X	Replace fan drive bearing (if necessary).
SL2- 7220	Fan drive belt				X	Replace fan drive belt (if necessary).
SL2- 7410	Rubber hoses		18 years		X	Replace all rubber hose connections.

Activity identification	Component	Maintenance schedule		Maintenance activity		Description
		Operating hours (h)	Calendar interval (Day - Month - Year)	Check / clean	Replace	
SL2- 7420	Rubber sleeves		18 years		X	Replace all rubber sleeve connections.

Tab. 30: ESP - Version: MS2023/09-24

ESP (TOP POWER) - Version: MS2023/09-25

Service Level 2 extended maintenance activities, see service and repair manual.

Activity identification	Component	Maintenance schedule		Maintenance activity		Description
		Operating hours (h)	Calendar interval (Day - Month - Year)	Check / clean	Replace	
SL2- 1211	Combustion chamber		8 years	X		Check combustion chambers. Take corrective measures if there is a defect.
SL2- 3210	Coolant pump		18 years		X	Replace coolant pump.
SL2- 4210	Injector(s)		8 years		X	Replace injector(s).
SL2- 4220	Fuel high pressure pump		18 years		X	Replace fuel high pressure pump
SL2- 5410	Exhaust gas turbocharger		18 years		X	Replace the exhaust gas turbocharger.
SL2- 7212	Fan drive bearing				X	Replace fan drive bearing (if necessary).
SL2- 7220	Fan drive belt				X	Replace fan drive belt (if necessary).
SL2- 7410	Rubber hoses		18 years		X	Replace all rubber hose connections.
SL2- 7420	Rubber sleeves		18 years		X	Replace all rubber sleeve connections.

Tab. 31: ESP (TOP POWER) - Version: MS2023/09-25

5.2.8 Maintenance schedule – TIER 4 ESP Service Level 2

ESP - Version: MS2023/09-24

Service Level 2 extended maintenance activities, see service and repair manual.

Activity identification	Component	Maintenance schedule		Maintenance activity		Description
		Operating hours (h)	Calendar interval (Day - Month - Year)	Check / clean	Replace	
SL2- 1211	Combustion chamber		8 years	X		Check combustion chambers. Take corrective measures if there is a defect.
SL2- 3210	Coolant pump		18 years		X	Replace coolant pump.
SL2- 4210	Injector(s)		8 years		X	Replace injector(s).
SL2- 4220	Fuel high pressure pump		18 years		X	Replace fuel high pressure pump
SL2- 5330	Diesel exhaust fluid injector		8 years		X	Replace diesel exhaust fluid injector.
SL2- 5340	Diesel exhaust fluid pump		8 years		X	Replace pump for diesel exhaust fluid (DEF).
SL2- 5410	Exhaust gas turbo-charger		18 years		X	Replace the exhaust gas turbocharger.
SL2- 7212	Fan drive bearing				X	Replace fan drive bearing (if necessary).
SL2- 7220	Fan drive belt				X	Replace fan drive belt (if necessary).
SL2- 7410	Rubber hoses		18 years		X	Replace all rubber hose connections.
SL2- 7420	Rubber sleeves		18 years		X	Replace all rubber sleeve connections.

Tab. 32: ESP - Version: MS2023/09-24

ESP (TOP POWER) - Version: MS2023/09-25

Service Level 2 extended maintenance activities, see service and repair manual.

Activity identification	Component	Maintenance schedule		Maintenance activity		Description
		Operating hours (h)	Calendar interval (Day - Month - Year)	Check / clean	Replace	
SL2- 1211	Combustion chamber		8 years	X		Check combustion chambers. Take corrective measures if there is a defect.
SL2- 3210	Coolant pump		18 years		X	Replace coolant pump.
SL2- 4210	Injector(s)		8 years		X	Replace injector(s).
SL2- 4220	Fuel high pressure pump		18 years		X	Replace fuel high pressure pump
SL2- 5330	Diesel exhaust fluid injector		8 years		X	Replace diesel exhaust fluid injector.
SL2- 5340	Diesel exhaust fluid pump		8 years		X	Replace pump for diesel exhaust fluid (DEF).
SL2- 5410	Exhaust gas turbocharger		18 years		X	Replace the exhaust gas turbocharger.
SL2- 7212	Fan drive bearing				X	Replace fan drive bearing (if necessary).
SL2- 7220	Fan drive belt				X	Replace fan drive belt (if necessary).
SL2- 7410	Rubber hoses		18 years		X	Replace all rubber hose connections.
SL2- 7420	Rubber sleeves		18 years		X	Replace all rubber sleeve connections.

Tab. 33: ESP (TOP POWER) - Version: MS2023/09-25

5.2.9 Maintenance schedule – TIER 0-2 PRP Service Level 1

PRP - Version: MS2023/09-26

Activity identification	Component	Maintenance schedule		Maintenance activity		Description
		Operating hours (h)	Calendar interval (Day - Month - Year)	Check / clean	Replace	
SL1- 1122	Valves	1000	4 years	X		“Check valve clearance and set if necessary; note: 1st check at 500h as suggested in the maintenance schedule.”

Activity identification	Component	Maintenance schedule		Maintenance activity		Description
		Operating hours (h)	Calendar interval (Day - Month - Year)	Check / clean	Replace	
SL1- 1661	Crankcase breather system oil separator filter	2000	2 years		X	Replace oil separator filter.
SL1- 1662	Crankcase breather system V-ribbed belt	4000	2 years		X	Replace crankcase breather system V-ribbed belt.
SL1- 2020	Lubricating oil	500	2 years		X	Change engine oil (oil category 2).
SL1- 2021	Oil analysis	500	1 year	X		Take oil sample. Perform oil analysis. Take recommended measures according to the analysis results.
SL1- 2110	Oil filter	500	2 years		X	Replace oil filter. Clean engine side sealing area before and after filter removal.
SL1- 3020	Coolant	5000	4 years		X	Replace coolant.
SL1- 3021	Coolant analysis		1 year	X		Take a coolant sample. Perform coolant analysis. Take recommended measures according to the analysis results.
SL1- 3281	Belt drive for coolant pump and battery charging alternator	1000	1 year	X		Check belt, belt tensioning device and belt pulleys. Replace if a defect is present.
SL1- 4110	Primary fuel filter	1000	1 year		X	Replace primary fuel filter.
SL1- 4120	Main fuel filter	1000	1 year		X	Replace main fuel filter.
SL1- 5021	Air filter	3000	2 years		X	Check charge air pipe, tubes, hoses (also for wastegate / ventilation) and exhaust gas turbocharger (compressor blades, housing, connections, fastening). Take corrective measures if there is a defect.
SL1- 5201	Exhaust system	7500	4 years	X		Check exhaust system.
SL1- 5411	Exhaust gas turbo-charger	7500	4 years	X		Check exhaust gas turbocharger.
SL1- 7221	Fan drive belt drive	500	2 years	X		Check fan drive belt drive. Take corrective measures if there is a defect.

Tab. 34: PRP - Version: MS2023/09-26

5.2.10 Maintenance schedule – TIER 4 PRP Service Level 1

PRP - Version: MS2023/09-26

Activity identification	Component	Maintenance schedule		Maintenance activity		Description
		Operating hours (h)	Calendar interval (Day - Month - Year)	Check / clean	Replace	
SL1- 1122	Valves	1000	4 years	X		“Check valve clearance and set if necessary; note: 1st check at 500h as suggested in the maintenance schedule.”
SL1- 1661	Crankcase breather system oil separator filter	2000	2 years		X	Replace oil separator filter.
SL1- 1662	Crankcase breather system V-ribbed belt	4000	2 years		X	Replace crankcase breather system V-ribbed belt.
SL1- 2020	Lubricating oil	500	2 years		X	Change engine oil (oil category 2).
SL1- 2021	Oil analysis	500	1 year	X		Take oil sample. Perform oil analysis. Take recommended measures according to the analysis results.
SL1- 2110	Oil filter	500	2 years		X	Replace oil filter. Clean engine side sealing area before and after filter removal.
SL1- 3020	Coolant	5000	4 years		X	Replace coolant.
SL1- 3021	Coolant analysis		1 year	X		Take a coolant sample. Perform coolant analysis. Take recommended measures according to the analysis results.
SL1- 3281	Belt drive for coolant pump and battery charging alternator	1000	1 year	X		Check belt, belt tensioning device and belt pulleys. Replace if a defect is present.
SL1- 4110	Primary fuel filter	1000	1 year		X	Replace primary fuel filter.
SL1- 4120	Main fuel filter	1000	1 year		X	Replace main fuel filter.
SL1- 5021	Air filter	3000	2 years		X	Check charge air pipe, tubes, hoses (also for wastegate / ventilation) and exhaust gas turbocharger (compressor blades, housing, connections, fastening). Take corrective measures if there is a defect.
SL1- 5201	Exhaust system	7500	4 years	X		Check exhaust system.

Activity identification	Component	Maintenance schedule		Maintenance activity		Description
		Operating hours (h)	Calendar interval (Day - Month - Year)	Check / clean	Replace	
SL1- 5302	Exhaust gas after-treatment system		1 month	X		Check exhaust gas aftertreatment system.
SL1- 5310	Diesel exhaust fluid				X	Replace diesel exhaust fluid according to supplier documentation.
SL1- 5320	Diesel exhaust fluid filter	1500	6 months		X	Replace diesel exhaust fluid filter.
SL1- 5411	Exhaust gas turbo-charger	7500	4 years	X		Check exhaust gas turbocharger.
SL1- 7221	Fan drive belt drive	500	2 years	X		Check fan drive belt drive. Take corrective measures if there is a defect.

Tab. 35: PRP - Version: MS2023/09-26

5.2.11 Maintenance schedule – TIER 0-2 PRP Service Level 2

PRP - Version: MS2023/09-26

Service Level 2 extended maintenance activities, see service and repair manual.

Activity identification	Component	Maintenance schedule		Maintenance activity		Description
		Operating hours (h)	Calendar interval (Day - Month - Year)	Check / clean	Replace	
SL2- 1211	Combustion chamber	7500	8 years	X		Check combustion chambers. Take corrective measures if there is a defect.
SL2- 1340	Torsional vibration damper	7500	18 years		X	Replace fastening screws when torsional vibration damper is removed or replaced.
SL2- 3210	Coolant pump	7500	18 years		X	Replace coolant pump.
SL2- 3310	Coolant thermostat(s)	7500	18 years		X	Replace coolant thermostat(s).
SL2- 4210	Injector(s)	7500	8 years		X	Replace injector(s).

Activity identification	Component	Maintenance schedule		Maintenance activity		Description
		Operating hours (h)	Calendar interval (Day - Month - Year)	Check / clean	Replace	
SL2- 4220	Fuel high pressure pump	7500	18 years		X	Replace fuel high pressure pump
SL2- 5410	Exhaust gas turbo-charger		18 years		X	Replace the exhaust gas turbocharger.
SL2- 7212	Fan drive bearing	4000			X	Replace fan drive bearing.
SL2- 7220	Fan drive belt	4000	2 years		X	Replace fan drive belt.
SL2- 7410	Rubber hoses	7500	18 years		X	Replace all rubber hose connections.
SL2- 7420	Rubber sleeves	7500	18 years		X	Replace all rubber sleeve connections.

Tab. 36: PRP - Version: MS2023/09-26

5.2.12 Maintenance schedule – TIER 4 PRP Service Level 2

PRP - Version: MS2023/09-26

Service Level 2 extended maintenance activities, see service and repair manual.

Activity identification	Component	Maintenance schedule		Maintenance activity		Description
		Operating hours (h)	Calendar interval (Day - Month - Year)	Check / clean	Replace	
SL2- 1211	Combustion chamber	7500	8 years	X		Check combustion chambers. Take corrective measures if there is a defect.
SL2- 1340	Torsional vibration damper	7500	18 years		X	Replace fastening screws when torsional vibration damper is removed or replaced.
SL2- 3210	Coolant pump	7500	18 years		X	Replace coolant pump.
SL2- 3310	Coolant thermostat(s)	7500	18 years		X	Replace coolant thermostat(s).
SL2- 4210	Injector(s)	7500	8 years		X	Replace injector(s).

Activity identification	Component	Maintenance schedule		Maintenance activity		Description
		Operating hours (h)	Calendar interval (Day - Month - Year)	Check / clean	Replace	
SL2- 4220	Fuel high pressure pump	7500	18 years		X	Replace fuel high pressure pump
SL2- 5330	Diesel exhaust fluid injector	5000	8 years		X	Replace diesel exhaust fluid injector.
SL2- 5340	Diesel exhaust fluid pump	7500	8 years		X	Replace diesel exhaust fluid pump.
SL2- 5410	Exhaust gas turbo-charger		18 years		X	Replace the exhaust gas turbocharger.
SL2- 7212	Fan drive bearing	4000			X	Replace fan drive bearing.
SL2- 7220	Fan drive belt	4000	2 years		X	Replace fan drive belt.
SL2- 7410	Rubber hoses	7500	18 years		X	Replace all rubber hose connections.
SL2- 7420	Rubber sleeves	7500	18 years		X	Replace all rubber sleeve connections.

Tab. 37: PRP - Version: MS2023/09-26

5.2.13 Maintenance schedule – TIER 0-2 COP Service Level 1

COP - Version: MS2023/09-27

Activity identification	Component	Maintenance schedule		Maintenance activity		Description
		Operating hours (h)	Calendar interval (Day - Month - Year)	Check / clean	Replace	
SL1- 1122	Valves	1000	4 years	X		“Check valve clearance and set if necessary; note: 1st check at 500h as suggested in the maintenance schedule.”
SL1- 1661	Crankcase breather system oil separator filter	2000	2 years		X	Replace oil separator filter.

Activity identification	Component	Maintenance schedule		Maintenance activity		Description
		Operating hours (h)	Calendar interval (Day - Month - Year)	Check / clean	Replace	
SL1- 1662	Crankcase breather system V-ribbed belt	4000	2 years		X	Replace crankcase breather system V-ribbed belt.
SL1- 2020	Lubricating oil	500	2 years		X	Change engine oil (oil category 2).
SL1- 2021	Oil analysis	500	1 year	X		Take oil sample. Perform oil analysis. Take recommended measures according to the analysis results.
SL1- 2110	Oil filter	500	2 years		X	Replace oil filter. Clean engine side sealing area before and after filter removal.
SL1- 3020	Coolant	5000	4 years		X	Replace coolant.
SL1- 3021	Coolant analysis		1 year	X		Take a coolant sample. Perform coolant analysis. Take recommended measures according to the analysis results.
SL1- 3281	Belt drive for coolant pump and battery charging alternator	1000	1 year			Check belt, belt tensioning device and belt pulleys. Replace if a defect is present.
SL1- 4110	Primary fuel filter	1000	1 year		X	Replace primary fuel filter.
SL1- 4120	Main fuel filter	1000	1 year		X	Replace main fuel filter.
SL1- 5021	Air filter	3000	2 years		X	Check charge air pipe, tubes, hoses (also for wastegate / ventilation) and exhaust gas turbocharger (compressor blades, housing, connections, fastening). Take corrective measures if there is a defect.
SL1- 5201	Exhaust system	10000	4 years	X		Check exhaust system.
SL1- 5411	Exhaust gas turbocharger	5000	4 years	X		Check exhaust gas turbocharger.
SL1- 7221	Fan drive belt drive	500	2 years	X		Check fan drive belt drive. Take corrective measures if there is a defect.

Tab. 38: COP - Version: MS2023/09-27

5.2.14 Maintenance schedule – TIER 4 COP Service Level 1

COP - Version: MS2023/09-27

Activity identification	Component	Maintenance schedule		Maintenance activity		Description
		Operating hours (h)	Calendar interval (Day - Month - Year)	Check / clean	Replace	
SL1- 1122	Valves	1000	4 years	X		“Check valve clearance and set if necessary; note: 1st check at 500h as suggested in the maintenance schedule.”
SL1- 1661	Crankcase breather system oil separator filter	2000	2 years		X	Replace oil separator filter.
SL1- 1662	Crankcase breather system V-ribbed belt	4000	2 years		X	Replace crankcase breather system V-ribbed belt.
SL1- 2020	Lubricating oil	500	2 years		X	Change engine oil (oil category 2).
SL1- 2021	Oil analysis	500	1 year	X		Take oil sample. Perform oil analysis. Take recommended measures according to the analysis results.
SL1- 2110	Oil filter	500	2 years		X	Replace oil filter. Clean engine side sealing area before and after filter removal.
SL1- 3020	Coolant	5000	4 years		X	Replace coolant.
SL1- 3021	Coolant analysis		1 year	X		Take a coolant sample. Perform coolant analysis. Take recommended measures according to the analysis results.
SL1- 3281	Belt drive for coolant pump and battery charging alternator	1000	1 year			Check belt, belt tensioning device and belt pulleys. Replace if a defect is present.
SL1- 4110	Primary fuel filter	1000	1 year		X	Replace primary fuel filter.
SL1- 4120	Main fuel filter	1000	1 year		X	Replace main fuel filter.
SL1- 5021	Air filter	3000	2 years		X	Check charge air pipe, tubes, hoses (also for wastegate / ventilation) and exhaust gas turbocharger (compressor blades, housing, connections, fastening). Take corrective measures if there is a defect.
SL1- 5201	Exhaust system	10000	4 years	X		Check exhaust system.

Activity identification	Component	Maintenance schedule		Maintenance activity		Description
		Operating hours (h)	Calendar interval (Day - Month - Year)	Check / clean	Replace	
SL1- 5302	Exhaust gas after-treatment system		1 month	X		Check exhaust gas aftertreatment system.
SL1- 5310	Diesel exhaust fluid				X	Replace diesel exhaust fluid according to supplier documentation.
SL1- 5320	Diesel exhaust fluid filter	1500	6 months		X	Replace diesel exhaust fluid filter.
SL1- 5411	Exhaust gas turbocharger	5000	4 years	X		Check exhaust gas turbocharger.
SL1- 7221	Fan drive belt drive	500	2 years	X		Check fan drive belt drive. Take corrective measures if there is a defect.

Tab. 39: COP - Version: MS2023/09-27

5.2.15 Maintenance schedule – TIER 0-2 COP Service Level 2

COP - Version: MS2023/09-27

Service Level 2 extended maintenance activities, see service and repair manual.

Activity identification	Component	Maintenance schedule		Maintenance activity		Description
		Operating hours (h)	Calendar interval (Day - Month - Year)	Check / clean	Replace	
SL2- 1211	Combustion chamber	10000	8 years	X		Check combustion chambers. Take corrective measures if there is a defect.
SL2- 1340	Torsional vibration damper	10000	18 years		X	Replace fastening screws when torsional vibration damper is removed or replaced.
SL2- 3210	Coolant pump	10000	18 years		X	Replace coolant pump.
SL2- 3310	Coolant thermostat(s)	10000	18 years		X	Replace coolant thermostat(s).
SL2- 4210	Injector(s)	10000	8 years		X	Replace injector(s).

Activity identification	Component	Maintenance schedule		Maintenance activity		Description
		Operating hours (h)	Calendar interval (Day - Month - Year)	Check / clean	Replace	
SL2- 4220	Fuel high pressure pump	10000	18 years		X	Replace fuel high pressure pump
SL2- 5410	Exhaust gas turbo-charger	10000	18 years		X	Replace the exhaust gas turbocharger.
SL2- 7212	Fan drive bearing	4000			X	Replace fan drive bearing.
SL2- 7220	Fan drive belt	4000	2 years		X	Replace fan drive belt.
SL2- 7410	Rubber hoses	10000	18 years		X	Replace all rubber hose connections.
SL2- 7420	Rubber sleeves	10000	18 years		X	Replace all rubber sleeve connections.

Tab. 40: COP - Version: MS2023/09-27

5.2.16 Maintenance schedule – TIER 4 COP Service Level 2

COP - Version: MS2023/09-27

Service Level 2 extended maintenance activities, see service and repair manual.

Activity identification	Component	Maintenance schedule		Maintenance activity		Description
		Operating hours (h)	Calendar interval (Day - Month - Year)	Check / clean	Replace	
SL2- 1211	Combustion chamber	10000	8 years	X		Check combustion chambers. Take corrective measures if there is a defect.
SL2- 1340	Torsional vibration damper	10000	18 years		X	Replace fastening screws when torsional vibration damper is removed or replaced.
SL2- 3210	Coolant pump	10000	18 years		X	Replace coolant pump.
SL2- 3310	Coolant thermostat(s)	10000	18 years		X	Replace coolant thermostat(s).
SL2- 4210	Injector(s)	10000	8 years		X	Replace injector(s).

Operating fluids and maintenance

Maintenance schedule

Activity identification	Component	Maintenance schedule		Maintenance activity		Description
		Operating hours (h)	Calendar interval (Day - Month - Year)	Check / clean	Replace	
SL2- 4220	Fuel high pressure pump	10000	18 years		X	Replace fuel high pressure pump
SL2- 5330	Diesel exhaust fluid injector	5000	8 years		X	Replace diesel exhaust fluid injector.
SL2- 5340	Diesel exhaust fluid pump	10000	8 years		X	Replace pump for diesel exhaust fluid (DEF).
SL2- 5410	Exhaust gas turbo-charger	10000	18 years		X	Replace the exhaust gas turbocharger.
SL2- 7212	Fan drive bearing	4000			X	Replace fan drive bearing.
SL2- 7220	Fan drive belt	4000	2 years		X	Replace fan drive belt.
SL2- 7410	Rubber hoses	10000	18 years		X	Replace all rubber hose connections.
SL2- 7420	Rubber sleeves	10000	18 years		X	Replace all rubber sleeve connections.

Tab. 41: COP - Version: MS2023/09-27

5.3 Preliminary work

5.3.1 Bringing the engine into maintenance position

- ▶ Observe safety regulations ([→ 2 Safety, p. 26](#)).
- ▶ Make sure that engine is horizontal.
- ▶ Turn off engine.
- ▶ Let engine cool down to ambient temperature.
- ▶ Disconnect power supply and secure against reactivation.
- ▶ Label cut-off point.

5.4 1000 - Engine

5.4.1 Visual inspection (tightness, damage, loose parts) – SLO-1011

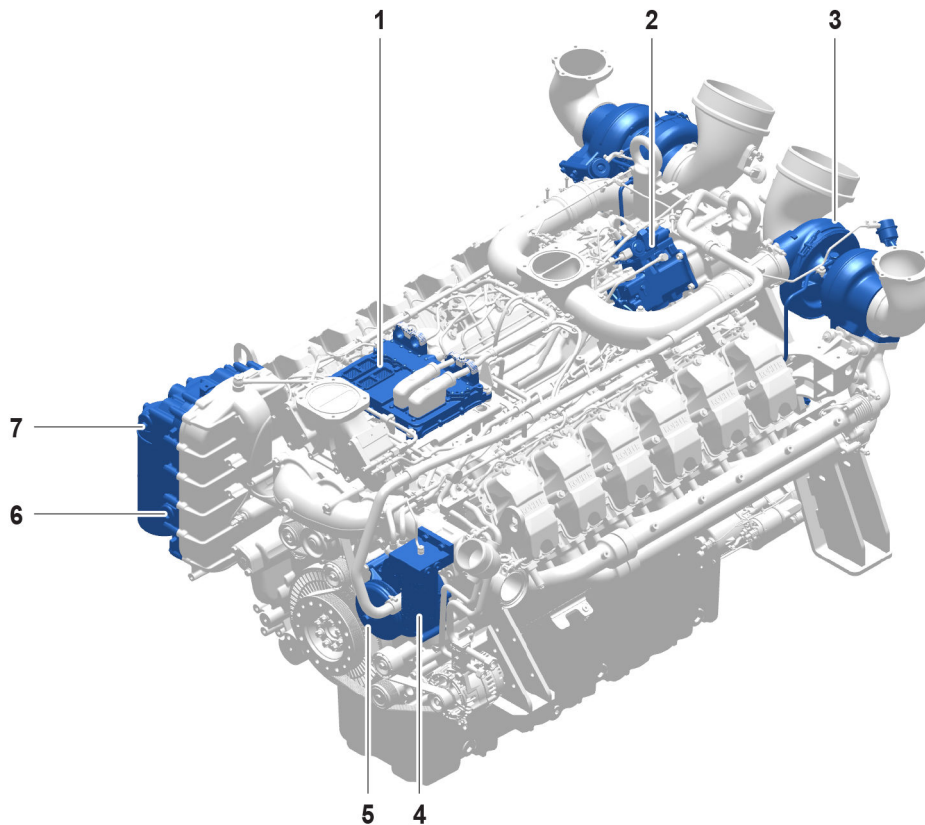

Fig. 27: Visual inspection (tightness, damage, loose parts)

- | | | | |
|----------|--------------------------|----------|---------------------------|
| 1 | Engine control unit | 5 | Crankcase breather system |
| 2 | Fuel high pressure pump | 6 | Oil module |
| 3 | Exhaust gas turbocharger | 7 | Oil filter |
| 4 | Main fuel filter | | |

- ▶ Visually check engine for leaks, ensure that it is not damaged and that the fastenings comply with regulations.
- ▶ Visually check V-space (area under fuel high pressure pump and lines) for moisture.

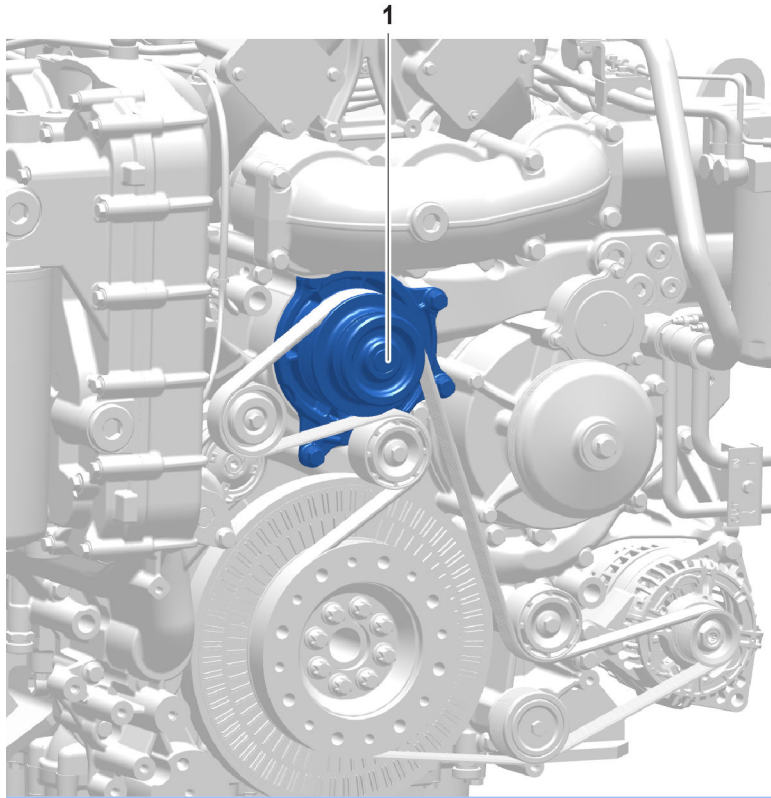

Fig. 28: Coolant pump visual inspection

1 Coolant pump

▶ Check area around coolant pump **1** for leaks.

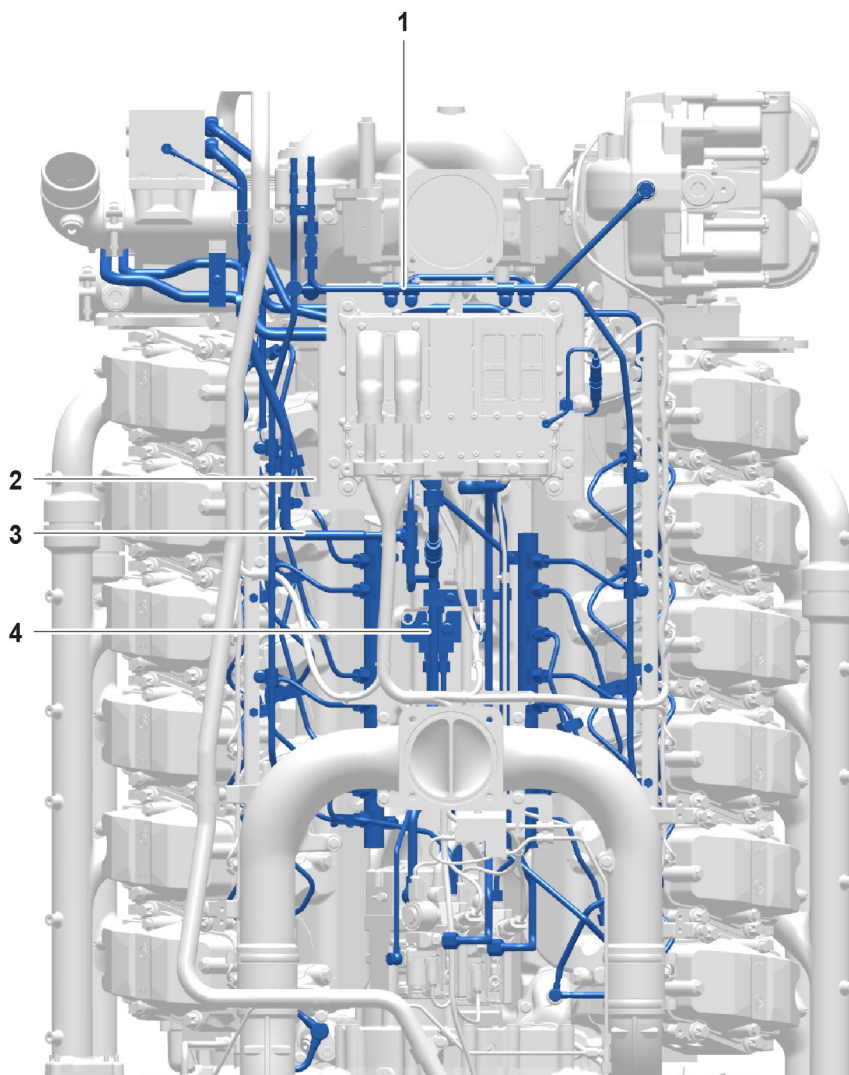

Fig. 29: Visual inspection of vent line, pressure line, fuel return line, fuel line

- | | | | |
|----------|---------------|----------|------------------|
| 1 | Vent line | 3 | Fuel return line |
| 2 | Pressure line | 4 | Fuel line |

- ▶ Visually check lines and hoses for leaks, ensure that they are not damaged, installed friction-free, and that fastening is in compliance with regulations.

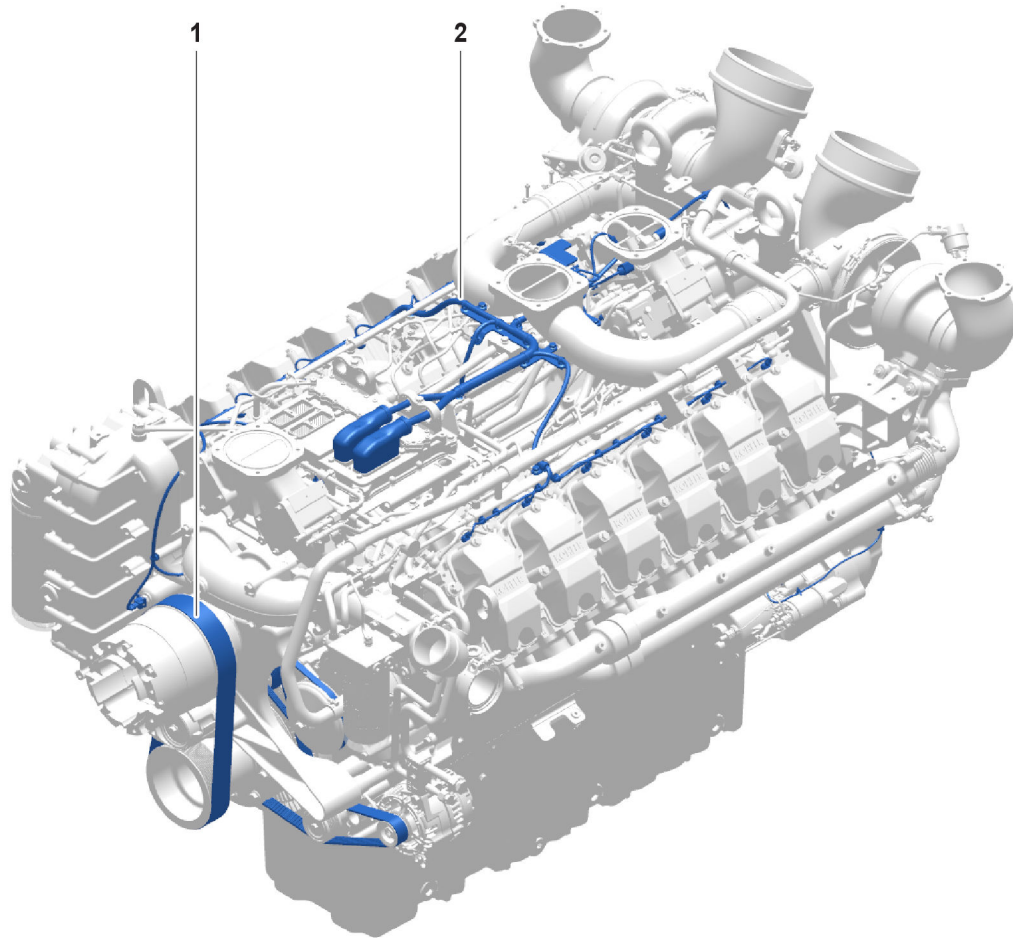

Fig. 30: Visual inspection of V-ribbed belt, cable harness

1 V-ribbed belt (3x)

2 Cable harness

- ▶ Visually check V-ribbed belt **1** for damage, friction-free installation, and regulation-compliant fastening.
- ▶ Visually check wiring harness **2** for damage, friction-free installation, and regulation-compliant fastening.

5.4.2 Observing the engine when idling – SLO-1021

- ▶ Watch out for incorrect parameters when idling.
- ▶ Watch out for unusual noises when idling.
- ▶ Watch out for unusual vibrations when idling.
- ▶ Watch out for unusual discoloration of the exhaust gases when idling.

5.4.3 Observing the engine in operation (only emergency power system - ESP application) – SLO-1022

- ▶ Watch out for incorrect parameters during operation.
- ▶ Watch out for unusual noises during operation.
- ▶ Watch out for unusual vibrations during operation.
- ▶ Watch out for unusual discoloration of the exhaust gases during operation.

5.4.4 Checking/setting the valve clearance – SL1-1122

- ▶ Check/set valve clearance, see documentation for the generator set.

5.4.5 Replacing the crankcase breather system oil separator filter – SL1-1661

Removing the crankcase breather system oil separator filter

Make sure that the following prerequisites are met:

- ❑ Crankcase breather system V-ribbed belt is removed (→ [5.4.6 Replacing the crankcase breather system V-ribbed belt – SL1-1662, p. 87](#)).
- ❑ A new filter insert is available.

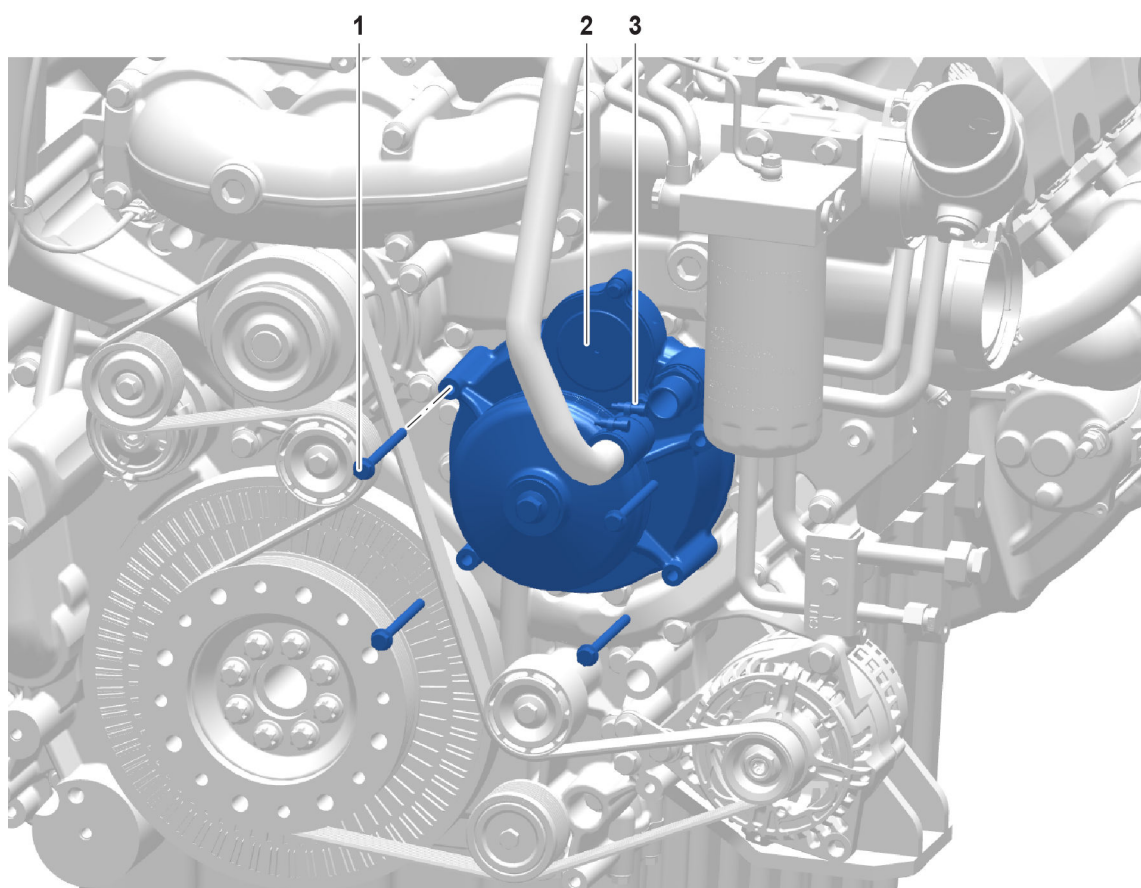

Fig. 31: Removing the crankcase breather system

- | | |
|------------------------------|------------------------------------|
| 1 Hex head screw (4x) | 3 Crankcase breather system |
| 2 Hose clamp (2x) | |

- ▶ Release hose clamps **2**.
- ▶ Remove line from crankcase breather system **3**.
- ▶ Unscrew hex head screws **1**.
- ▶ Remove crankcase breather system **3**.

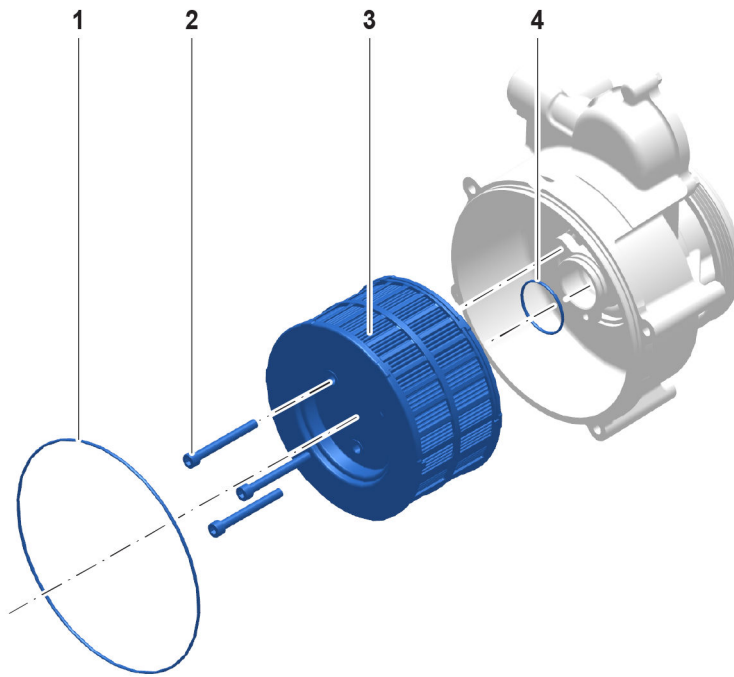

Fig. 32: Removing the filter insert

- | | | | |
|----------|------------------------|----------|---------------|
| 1 | O-ring | 3 | Filter insert |
| 2 | Socket head screw (3x) | 4 | O-ring |
- ▶ Remove o-ring **1**.
 - ▶ Unscrew socket head screws **2**.
 - ▶ Remove filter insert **3**.
 - ▶ Remove o-ring **4**.

Cleaning

- ▶ Clean o-ring grooves with a lint-free cloth.

Installing the crankcase breather system oil separator filter

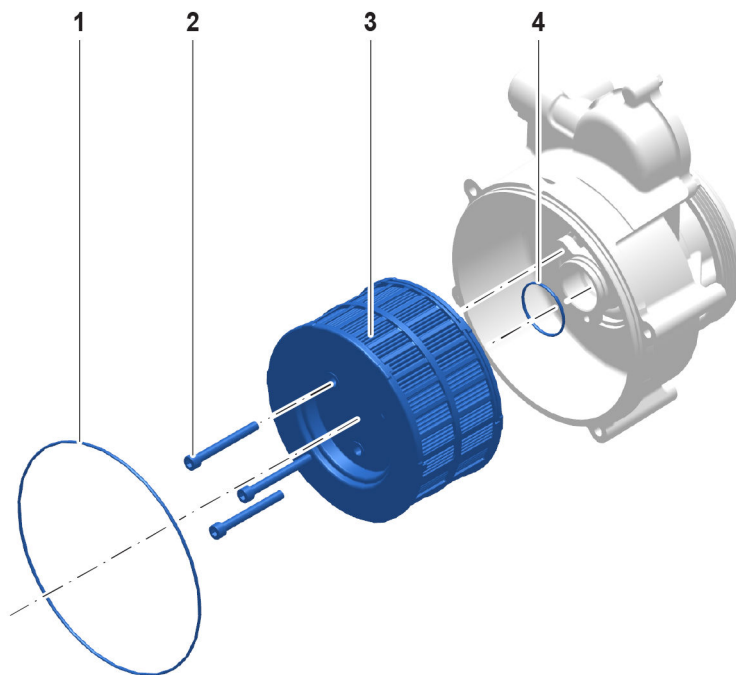

Fig. 33: Installing the filter insert

- | | | | |
|----------|------------------------|----------|---------------|
| 1 | O-ring | 3 | Filter insert |
| 2 | Socket head screw (3x) | 4 | O-ring |

- ▶ Coat new o-ring **4** with NBU 30 lubricating grease.
- ▶ Install new o-ring **4**.
- ▶ Install filter insert **3**.
- ▶ Tighten socket head screw **2**.
- ▶ Coat new o-ring **1** with NBU 30 lubricating grease.
- ▶ Install new o-ring **1**.

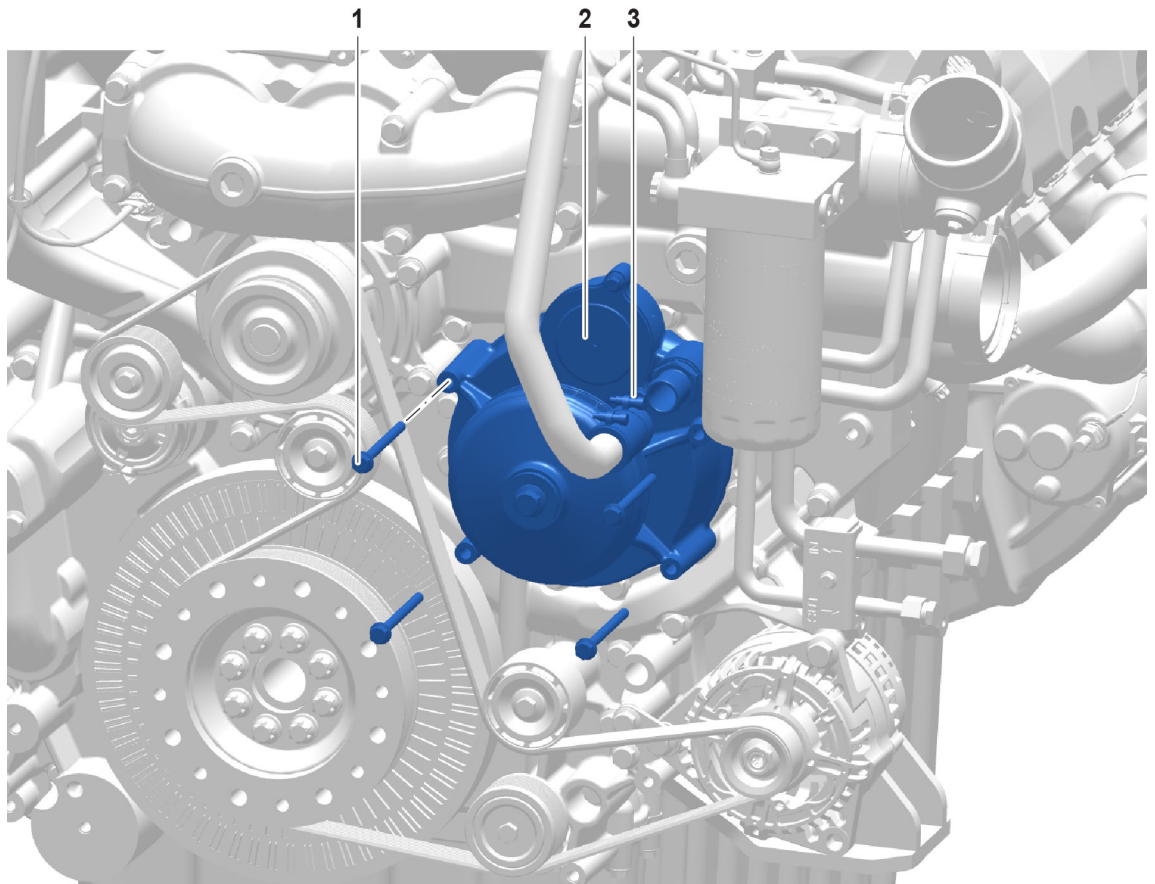

Fig. 34: Removing the crankcase breather system

- | | |
|------------------------------|------------------------------------|
| 1 Hex head screw (4x) | 3 Crankcase breather system |
| 2 Hose clamp (2x) | |
- ▶ Install crankcase breather system **3**.
 - ▶ Tighten hex head screws **1**.
 - ▶ Install line of crankcase breather system **3**.
 - ▶ Tighten hose clamps **2**.

5.4.6 Replacing the crankcase breather system V-ribbed belt – SL1-1662

Checking the crankcase breather system V-ribbed belt

Damage to the V-ribbed belt includes:

- Broken ribs
- Rubber nodules in the base of the belt
- Dirt and/or stone deposits
- Ribs broken off the base of the belt
- Transverse cracks on the back
- Transverse cracks in several ribs

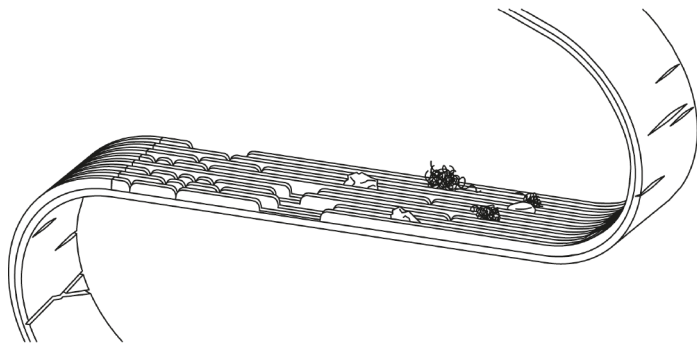

Fig. 35: Damage to the V-ribbed belt



WARNING

Rotating components!
Risk of injury. Can cause serious injuries.

- ▶ Turn off engine.
 - ▶ Secure the engine against unexpected start-up.
-

Removing the crankcase breather system V-ribbed belt

Make sure that the following prerequisites are met:

- A new V-ribbed belt is available.
- A socket wrench set with lever is available.
- Turning device ID no. 10123791 is available.
- An additional person is present.

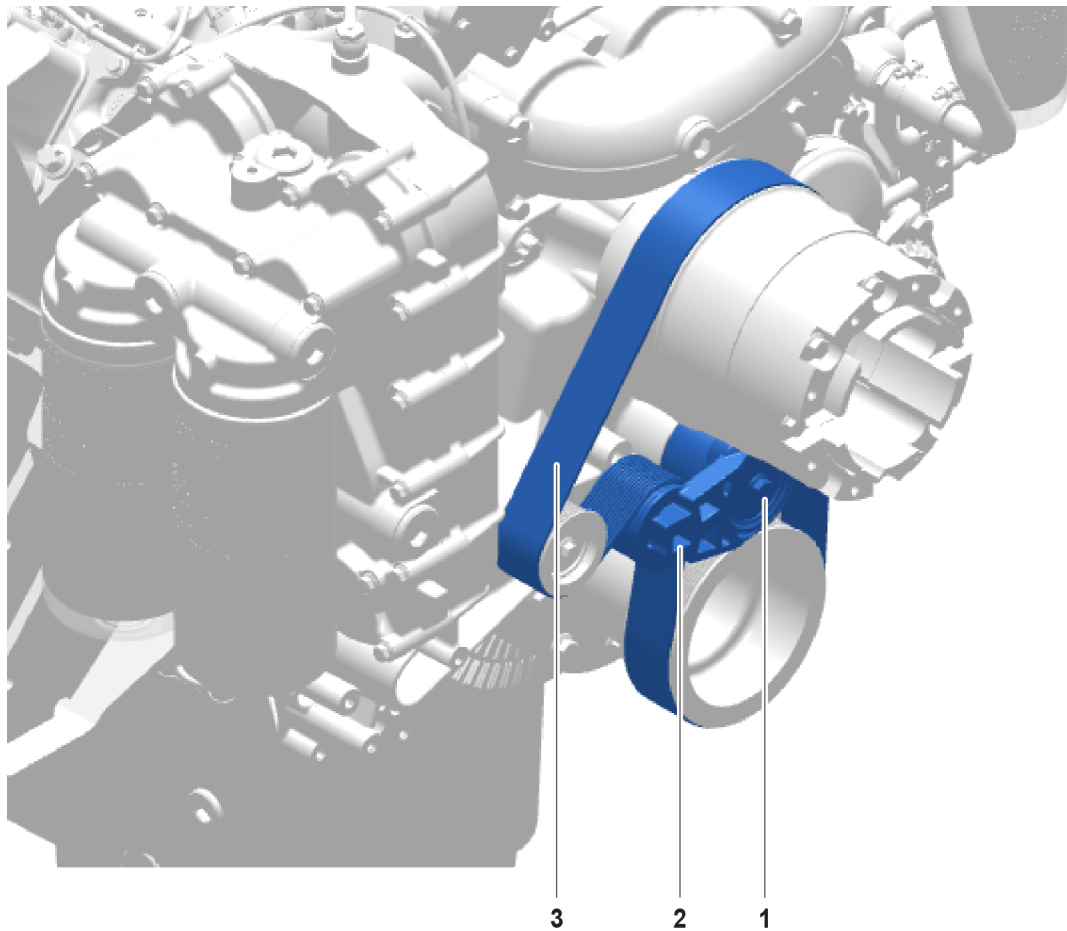

Fig. 36: Removing the fan drive V-ribbed belt

- 1** Tension pulley (self-tensioning) **3** V-ribbed belt
2 Internal square



WARNING

Unexpected recoil of the tensioner (self tensioning)!
Injuries.

- ▶ Make sure that the tool is correctly connected to tension pulley (self-tensioning).
 - ▶ Carefully swivel tensioner (self tensioning).
 - ▶ When V-ribbed belt is loose, do not let go of tool on tension pulley (self-tensioning).
-
- ▶ Remove fan on the fan drive. See operation and maintenance manual for the generator set.
 - ▶ Turn tension pulley (self-tensioning) **1** with internal square **2** counterclockwise against the spring force to the limit stop.
 - ▷ V-ribbed belt **3** is relaxed.
 - ▶ Remove V-ribbed belt **3**.
 - ▶ Check that the belt pulleys and tension pulley (self-tensioning) **1** are in perfect working order and check their play (for example, tread wear on belt pulleys).
 - ▷ Replace damaged parts.

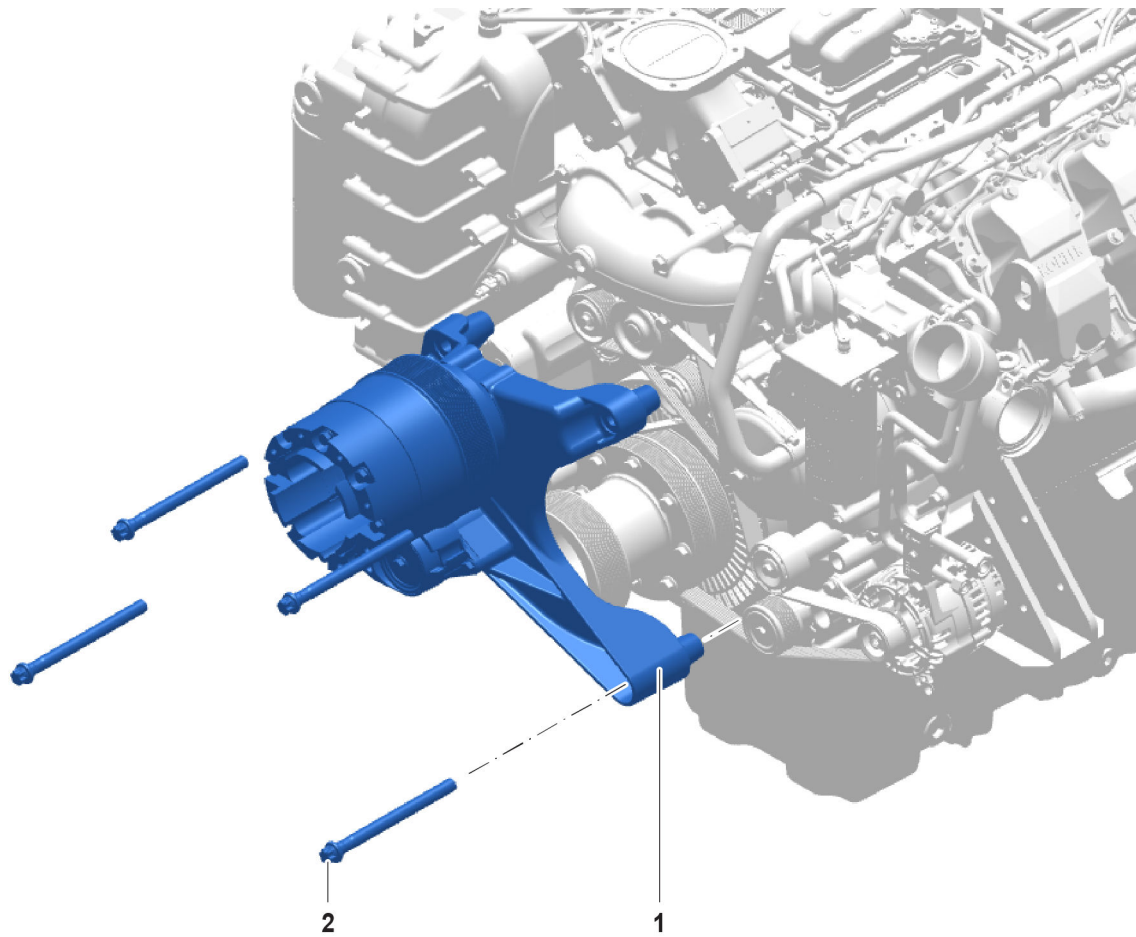

Fig. 37: Removing the console

1 Console

2 Hexalobular flange head screw (4x)

▶ Unscrew hexalobular flange head screws **2**.

▶ Remove console **1**.

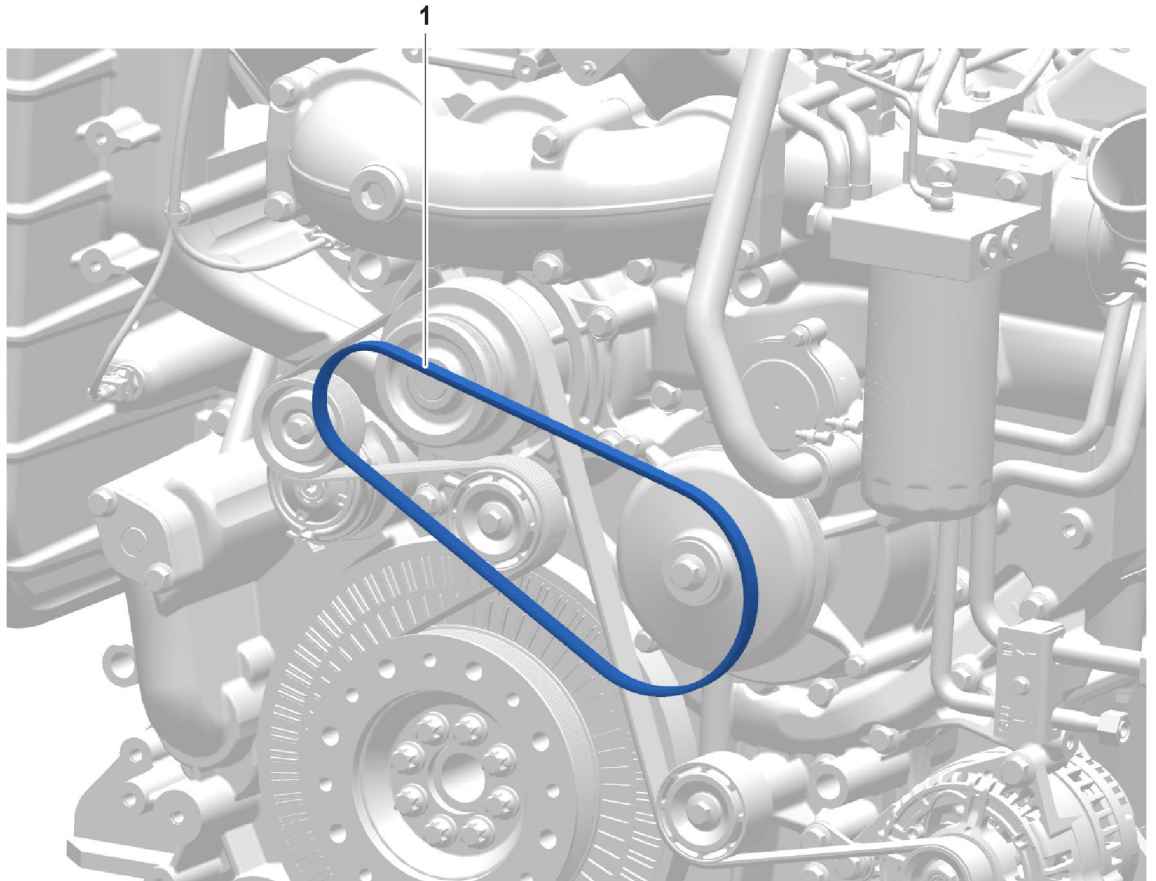

Fig. 38: Removing the crankcase breather system V-ribbed belt

1 Crankcase breather system V-ribbed belt

While an additional person operates the turning device:

▶ Remove crankcase breather system V-ribbed belt **1**.

Installing the crankcase breather system V-ribbed belt

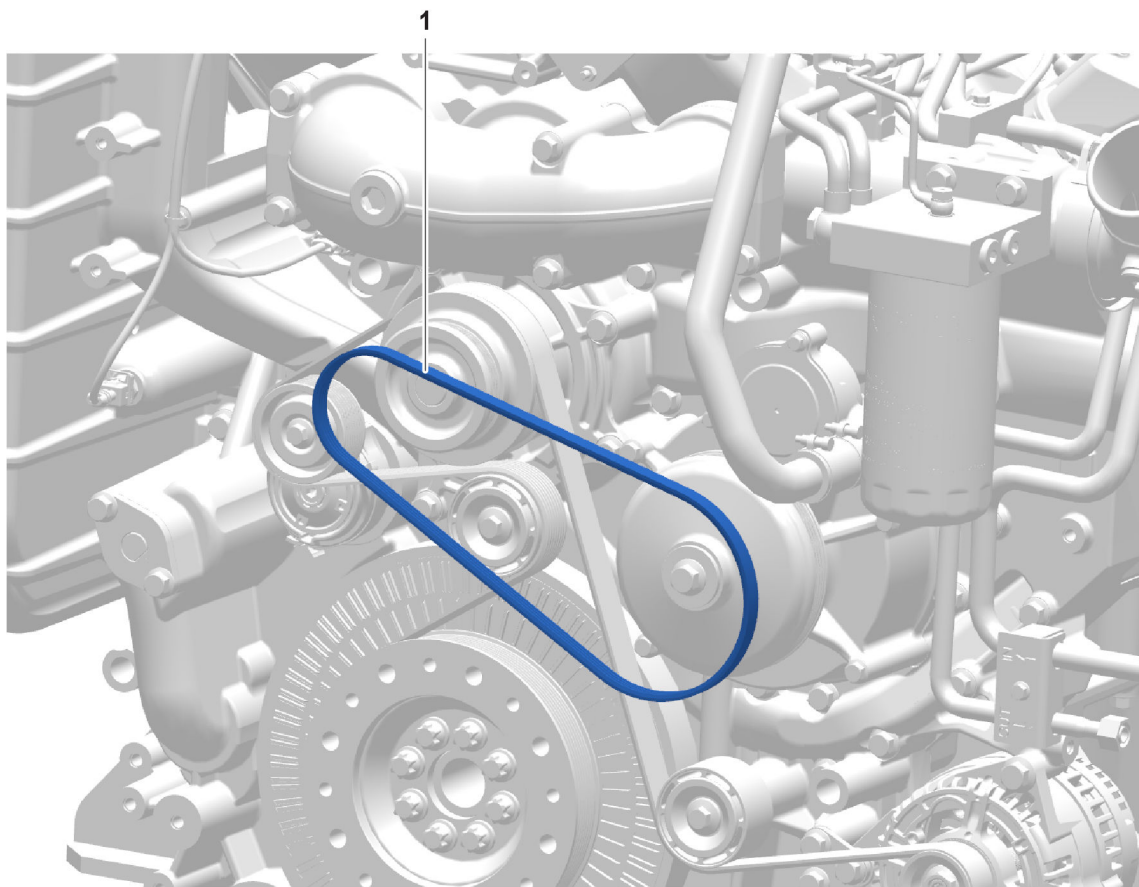

Fig. 39: Installing the crankcase breather system V-ribbed belt

1 Crankcase breather system V-ribbed belt

While an additional person operates the turning device:

- ▶ Install new crankcase breather system V-ribbed belt **1**, ensuring it is properly seated.

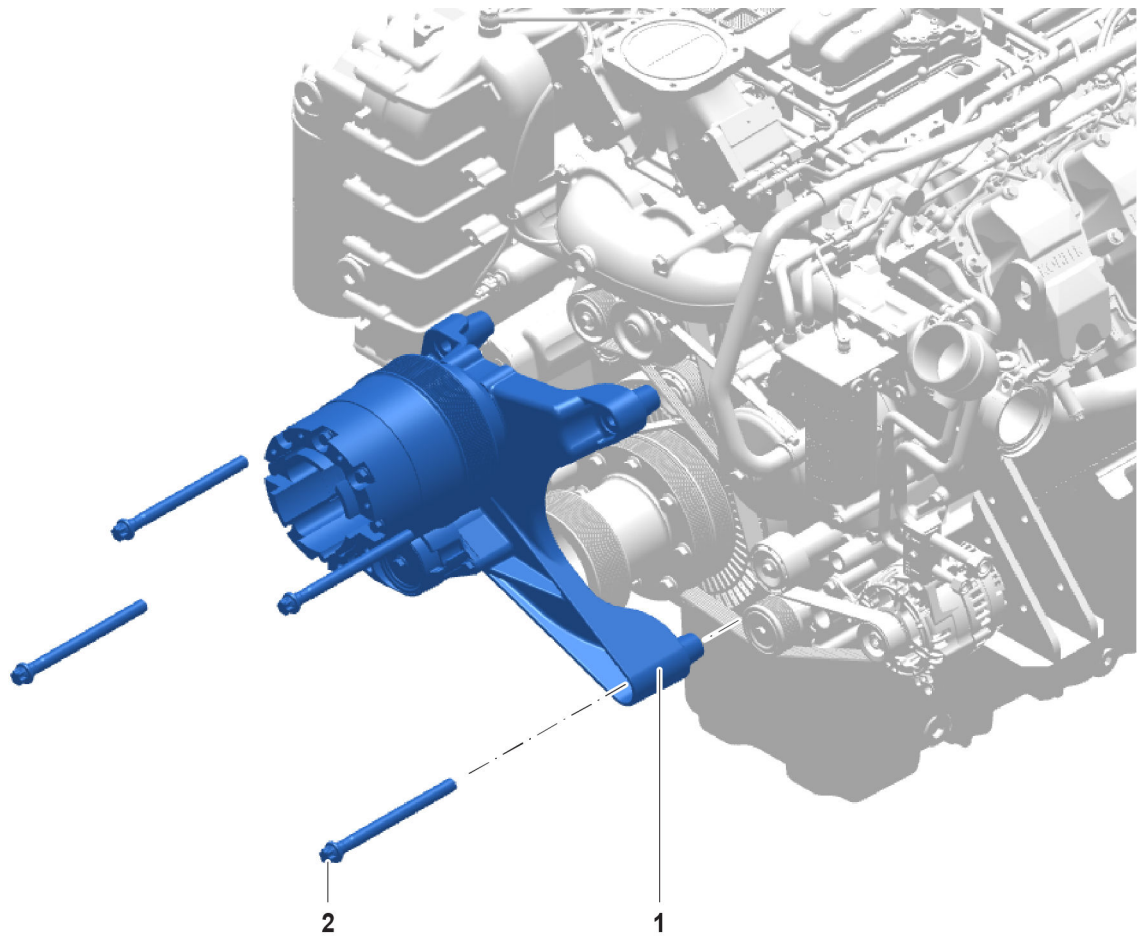

Fig. 40: Installing the console

1 Console

2 Hexalobular flange head screw (4x)

► Install console **1**.

Tightening instruction for M18 10.9 E24 hexalobular flange head screw		
Lubricant	-	
Threadlock	-	
Component contact surfaces	-	
Screws	Reuse possible	
Stage	Tightening torque	
1.	125 Nm	
2.	250 Nm	

Tab. 42: Tightening instruction

► Tighten hexalobular flange head screws **2** according to tightening instruction.

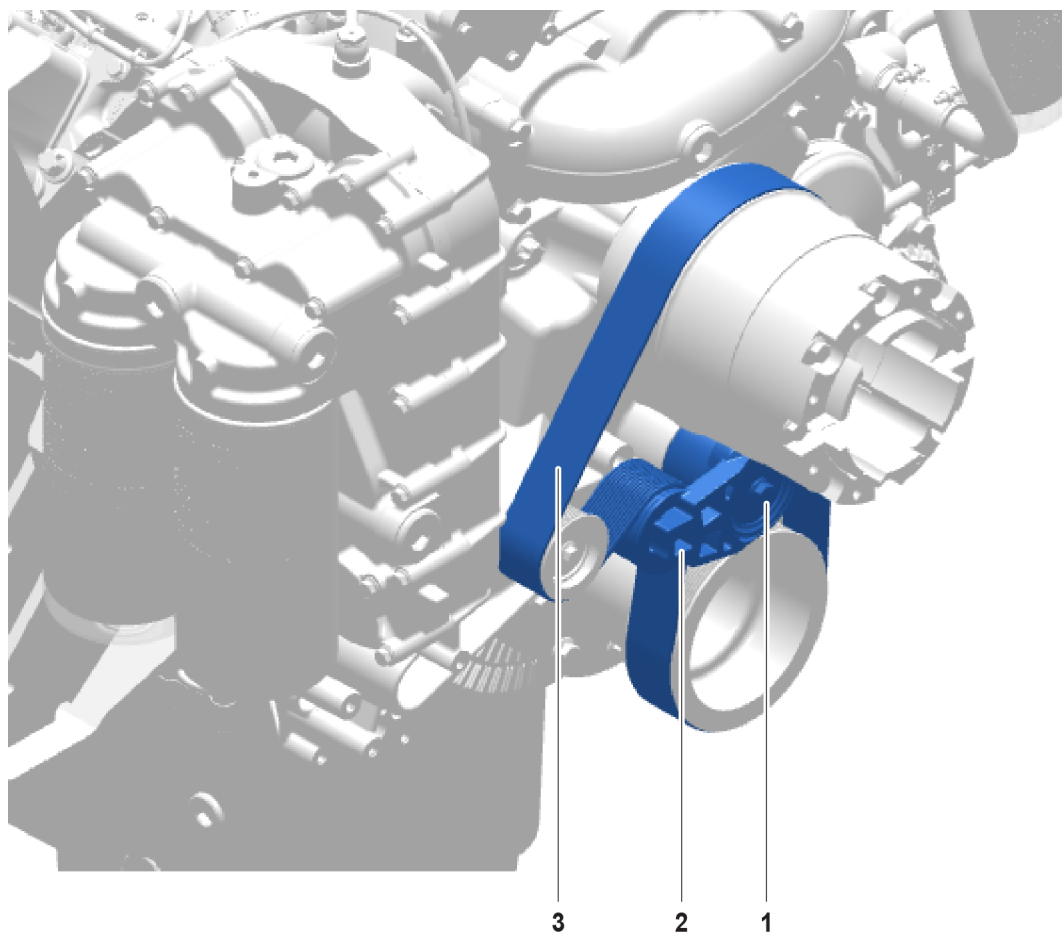

Fig. 42: Installing the V-ribbed belt for the crankcase breather system

- | | |
|---|------------------------|
| 1 Tension pulley (self-tensioning) | 3 V-ribbed belt |
| 2 Internal square | |

- ▶ Turn tension pulley (self-tensioning) **1** with internal square **2** counterclockwise against the spring force to the limit stop.
- ▶ Fit V-ribbed belt **3** with tension pulley (self-tensioning) **1** pivoted back.
- ▶ Turn tension pulley (self-tensioning) **1** carefully to original position.
 - ▷ V-ribbed belt **3** is tensioned.



Information

After proper installation of the V-ribbed belt, allow it to run in for 30 minutes. Check pretension and retighten if necessary.

5.5 2000 - Lubrication system

5.5.1 Checking the oil level – SL0-2011

Make sure that the following prerequisites are met:

- ❑ The engine is horizontal.
- ❑ The engine is turned off

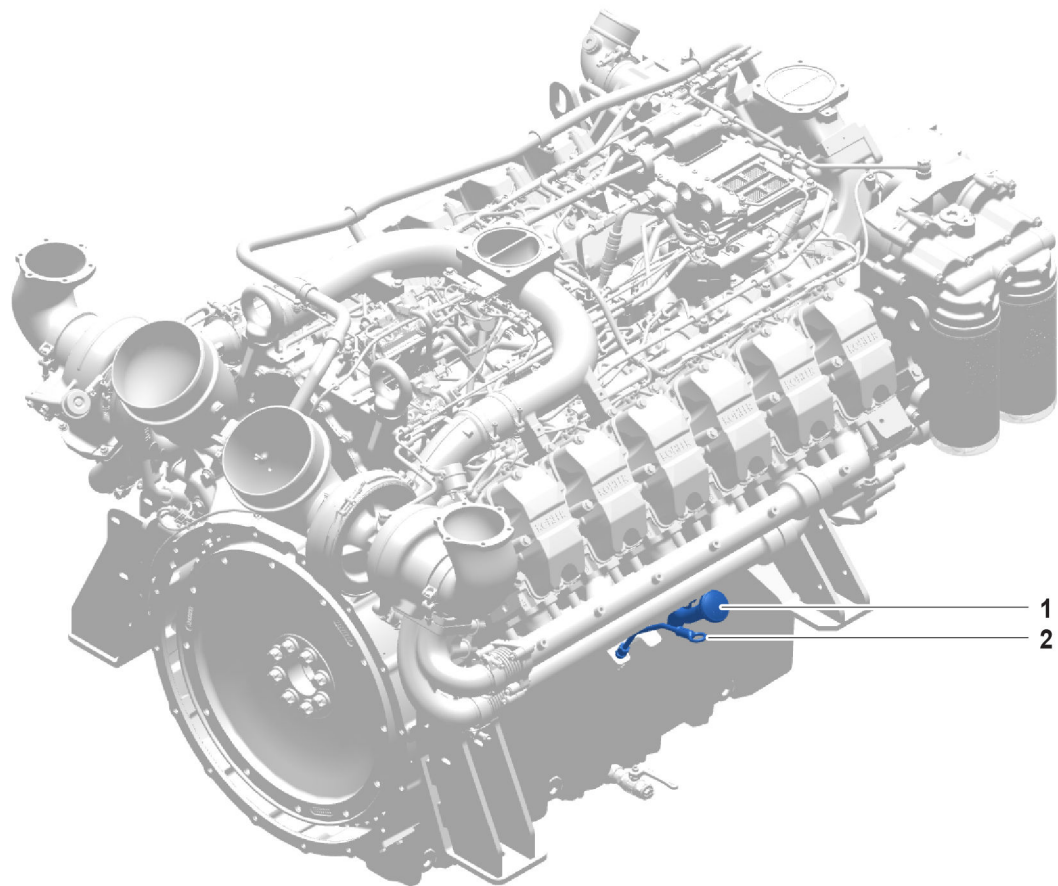

Fig. 43: Checking the oil level

1 Oil filler neck

2 Oil dipstick

▶ Pull out oil dipstick **2**, wipe with a clean cloth and reinsert to limit stop.

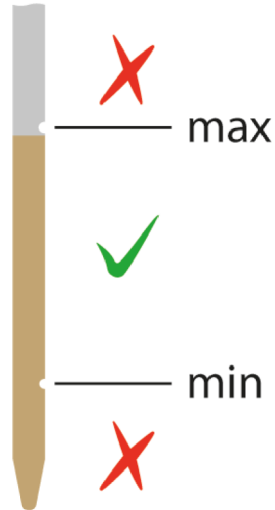

Fig. 44: Oil level

- ▶ Remove oil dipstick **2** again and check oil level. The oil level must be between “min” and “max”.

If the oil level is below the “min” mark:

- ▶ Refill lubricating oil.
- ▶ Remove oil filler cap and refill oil.
- ▶ Fill oil through oil filler neck **1**.
- ▶ Do not fill engine with oil above the “max” mark.
- ▶ Clean filler cap, place on filler neck and tighten.

5.5.2 Changing the lubricating oil – SL1-2020

Make sure that the following prerequisites are met:

- The engine is horizontal.
- The engine is turned off
- The engine is warm, unlike in the maintenance position.
- Strap wrench or similar tool is on hand.
- A collection container with the required capacity is available.
- Oil filters with seals are available.
- Lubricating oil is available. For lubricating oil quantity, see “Fill quantities table” chapter. For lubricating oil specification, see “Lubricants and operating fluids” chapter.

Draining the lubricating oil

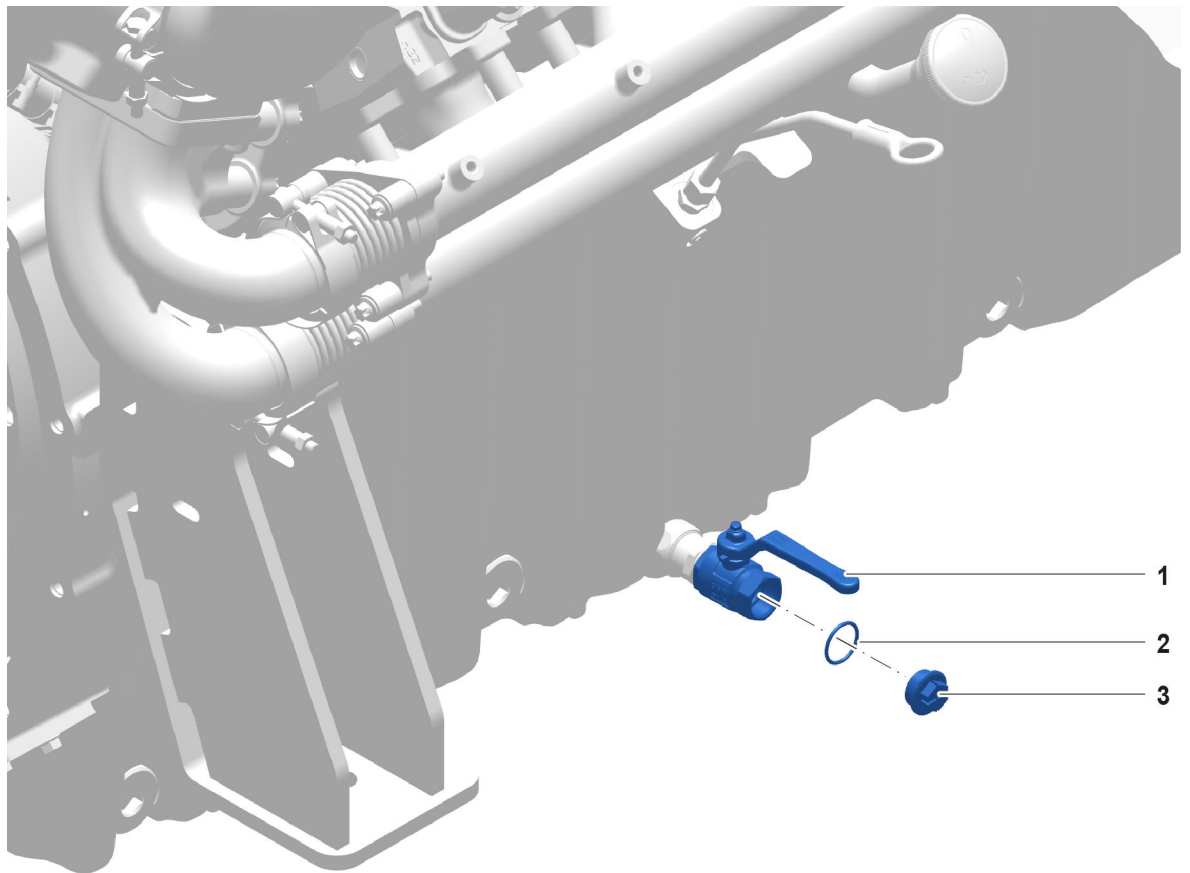

Fig. 45: Draining the lubricating oil

- 1** Oil drain shut-off valve
- 2** O-ring

- 3** Sealing plug

- ▶ Remove sealing plug **3** with o-ring **2**.
- ▶ Open oil drain shut-off valve **1**.
- ▶ Drain oil into collection container provided.
- ▶ Close oil drain shut-off valve **1**.
- ▶ Dispose of oil (observe country-specific regulations).

Filling the lubricating oil

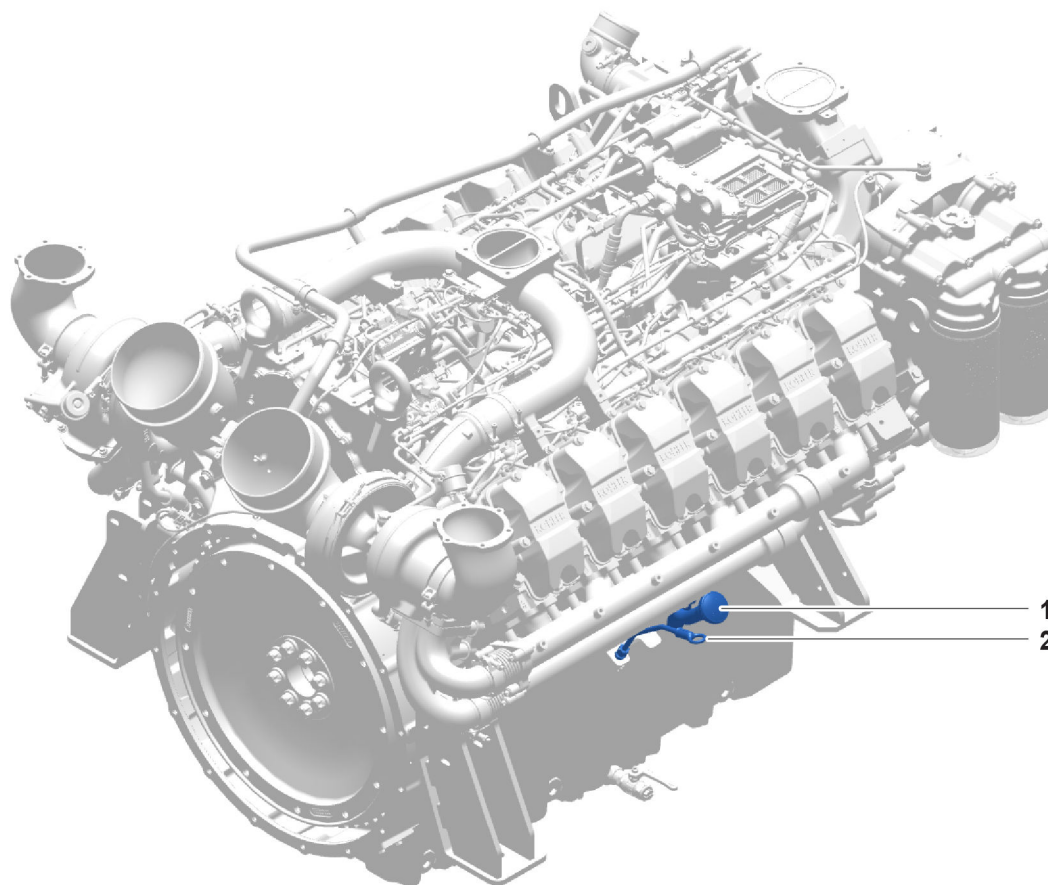

Fig. 46: Filling the lubricating oil

1 Oil filler neck

2 Oil dipstick

- ▶ Fill oil via oil filler neck **1** to between min and max on oil dipstick **2**.
- ▶ Clean the refueling cap, place on the oil filler neck **1** and tighten.
- ▶ Start engine.
- ▶ Check oil pressure (engine oil pressure display unit) and tightness on oil filter.
- ▶ Turn off engine.
- ▶ Check oil level on oil dipstick **2** after 10 minutes.

If the oil level is not between min and max:

- ▶ Correct oil level.

5.5.3 Taking an oil sample and performing an oil analysis – SL1-2021

Make sure that the following prerequisites are met:

- A collection container with the required capacity is available.
- A suitable sample bottle is ready.

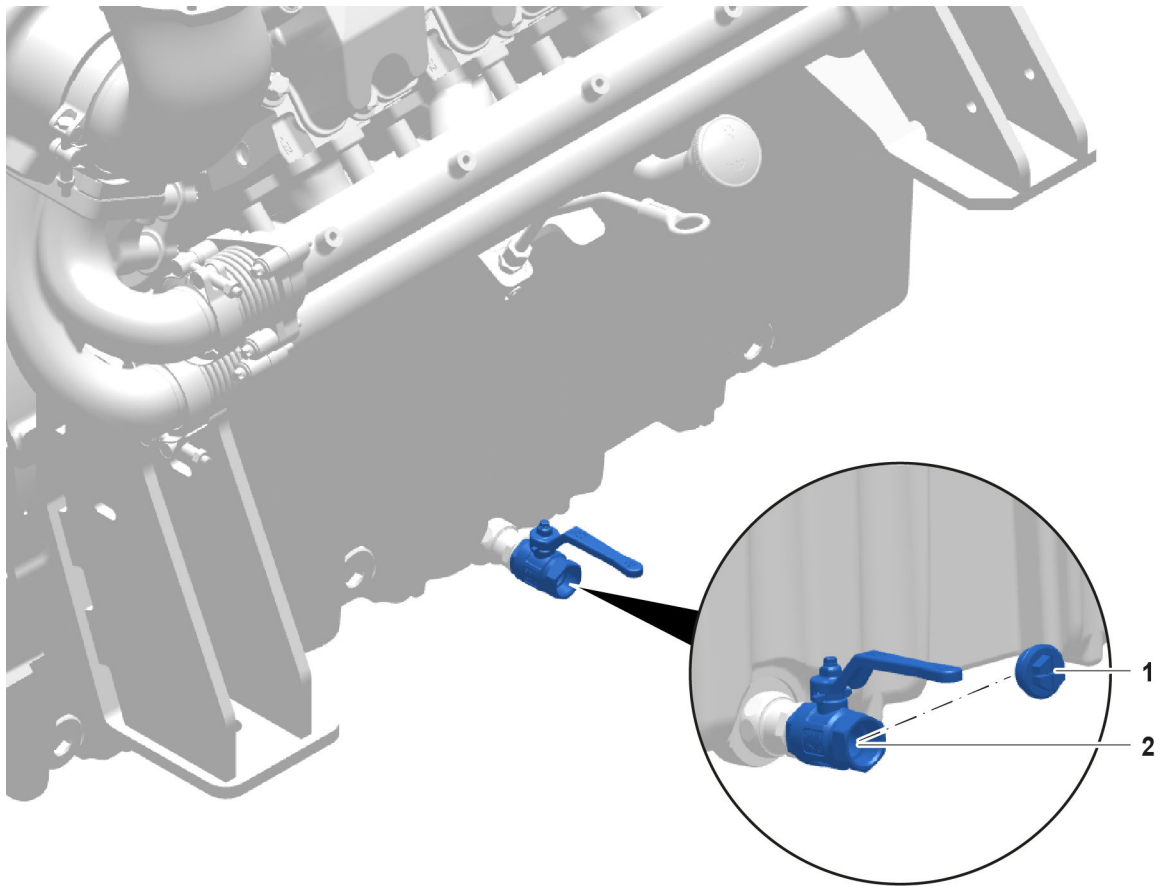

Fig. 47: Oil removal point

1 Protecting cap

2 Shut-off valve

- ▶ See operation and maintenance manual for the generator set for procedure for taking an oil sample and performing an oil analysis.

5.5.4 Replacing the oil filter – SL1-2110

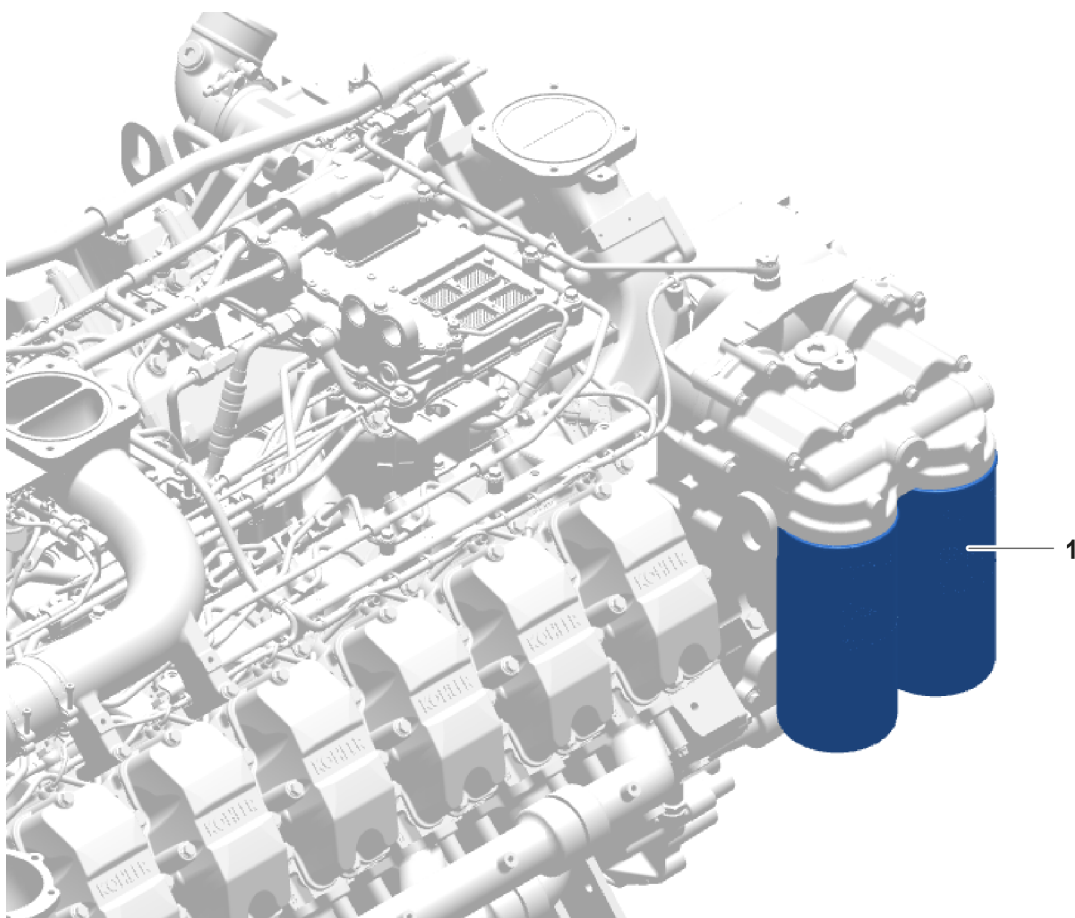

Fig. 48: Replacing the oil filter

1 Oil filter

- ▶ Release oil filter **1** with a strap wrench or similar tool and unscrew it.



WARNING

Hot engine oil!
Risk of burns! Can cause injuries.

- ▶ Avoid skin contact with the engine oil.
 - ▶ Wear protective gloves when changing the engine oil.
-
- ▶ Dispose of oil filter (observe country-specific regulations).
 - ▶ Coat seal on oil filter **1** with lubricating oil.
 - ▶ Screw in new oil filter **1** until sealing ring rests against oil module.

Tightening instruction for oil filter (hexagon socket wrench size 17 mm)	
Lubricant	Lubricating oil
Threadlock	-
Component contact surfaces	-
Screws	-
Stage	Tightening torque
1.	Screw in by hand until seal is in place
2.	1/2 turn (25 ⁺⁵ Nm)



Tab. 43: Tightening instruction

- ▶ Tighten oil filter **1** according to tightening instruction.

5.6 3000 - Cooling system

5.6.1 Checking the coolant level – SLO-3011



WARNING

Hot cooler parts and hot coolant!
Serious burns possible.

- ▶ Let engine cool down to below 50 °C.
- ▶ Put on protective gloves.
- ▶ Put on safety glasses.



Fig. 50: Hot cooler parts

- ▶ For procedure to check the coolant level, see documentation for the generator set.
- If the coolant level is too low or too high:
- ▶ Do not start engine.
 - ▶ Refill coolant, see documentation for the generator set.

5.6.2 Replacing the coolant – SL1-3020

- ▶ Replace coolant, see documentation for the generator set.

5.6.3 Taking a coolant sample and performing a coolant analysis – SL1-3021

Make sure that the following prerequisite is met:

- A collection container for coolant sample is available.



WARNING

Hot cooler parts and hot coolant!
Serious burns possible.

- ▶ Let engine cool down to below 50 °C.
- ▶ Put on protective gloves.
- ▶ Put on safety glasses.

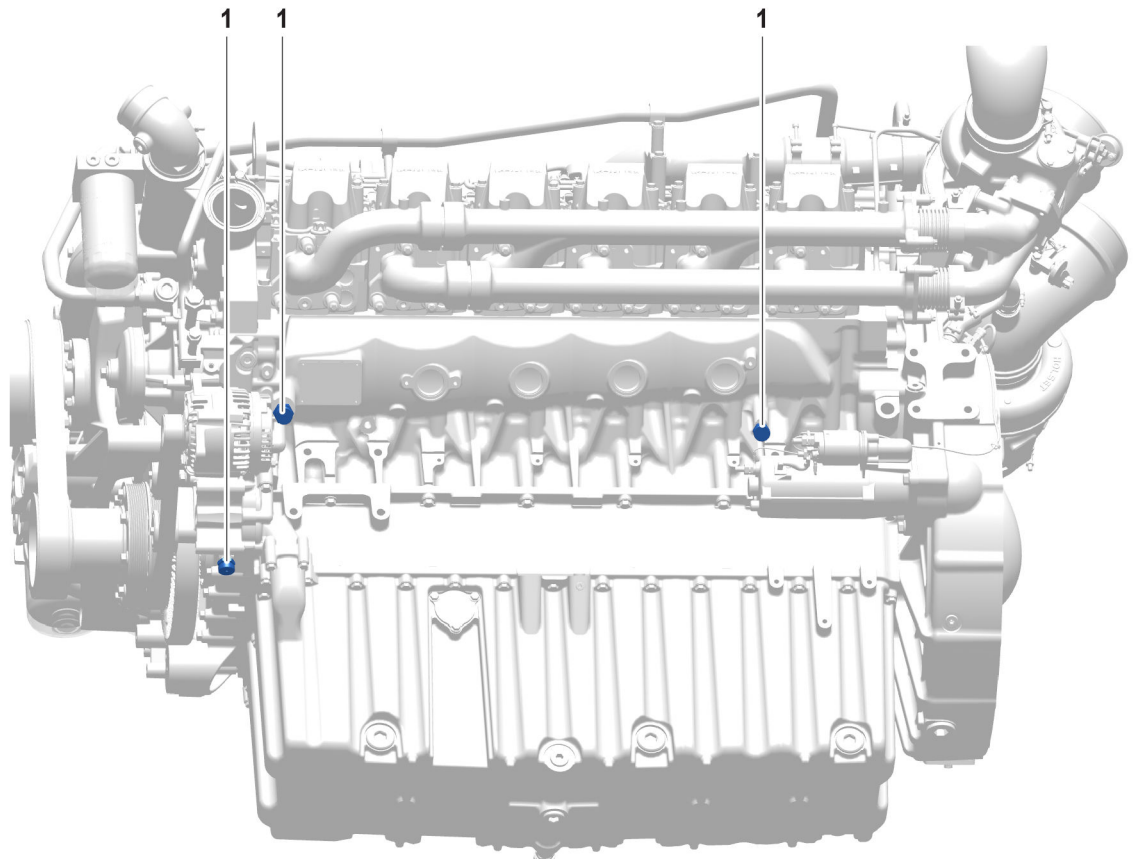

Fig. 51: Coolant sampling point

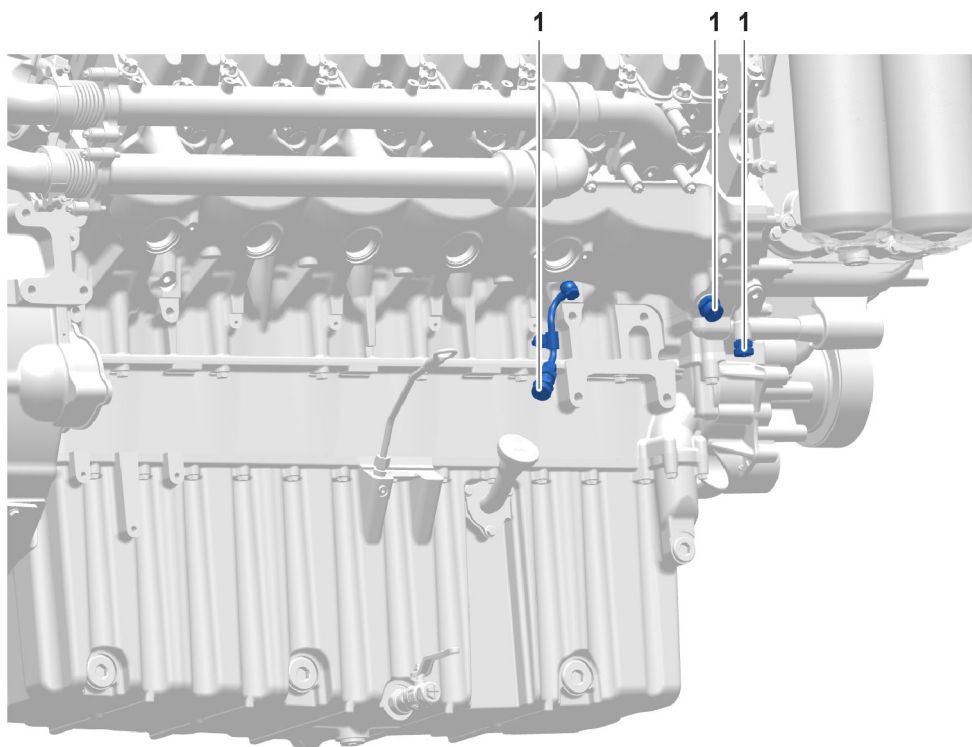

Fig. 52: Coolant sampling point

1 Coolant drain valves

► Remove coolant, see documentation for the generator set.

5.6.4 Checking and replacing the belt drive for the coolant pump and battery charging alternator – SL1-3281

Checking the belt drive for the coolant pump and battery charging alternator

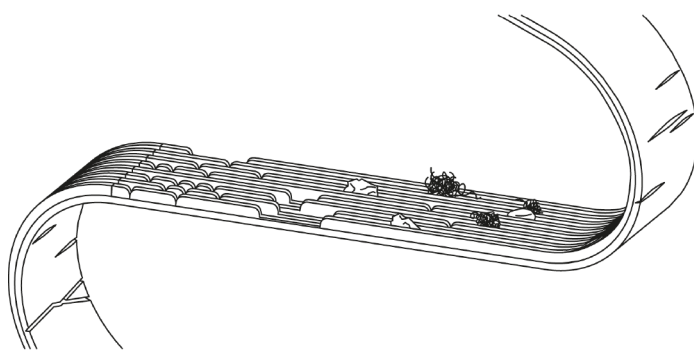

Fig. 53: Damage to the V-ribbed belt

- Broken ribs
- Rubber nodules in the base of the belt
- Dirt and/or stone deposits
- Ribs broken off the base of the belt
- Transverse cracks on the back
- Transverse cracks in several ribs

Removing the belt drive for the coolant pump and battery charging alternator

Make sure that the following prerequisites are met:

- ❑ Crankcase breather system V-ribbed belt is removed (→ [5.4.6 Replacing the crankcase breather system V-ribbed belt – SL1-1662, p. 87](#)).
- ❑ A new V-ribbed belt is available.

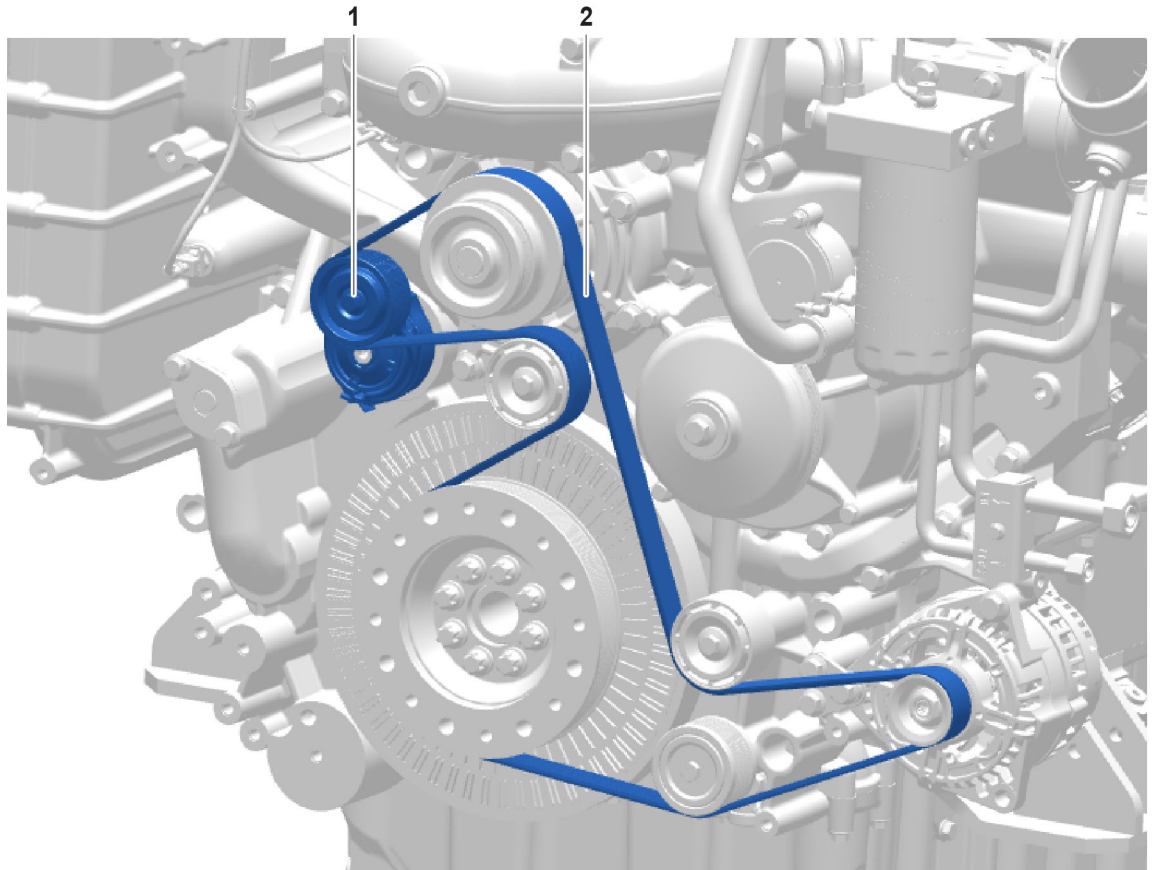

Fig. 54: Removing the belt drive for the coolant pump and battery charging alternator

- 1 Tension pulley (self-tensioning) 2 V-ribbed belt



WARNING

Rotating components!
Risk of injury. Can cause serious injuries.

- ▶ Turn off engine.
- ▶ Secure the engine against unexpected start-up.



WARNING

Unexpected recoil of the tensioner (self tensioning)!
Injuries.

- ▶ Make sure that the tool is correctly connected to tension pulley (self-tensioning).
- ▶ Carefully swivel tensioner (self tensioning).
- ▶ When V-ribbed belt is loose, do not let go of tool on tension pulley (self-tensioning).

- ▶ Attach external hexagon socket wrench size 13 mm with lever to tension pulley screw (tension pulley screw has a left-handed thread).
- ▶ Turn tension pulley (self-tensioning) **1** counterclockwise against the spring force to the limit stop.
 - ▷ V-ribbed belt **2** is relaxed.
- ▶ Remove V-ribbed belt **2**.
- ▶ Check that the belt pulleys and tension pulley are in perfect working order and check their play (for example, worn out bearings on tension pulley or tread wear on belt pulleys).
 - ▷ Replace damaged parts. Please contact the nearest authorized Kohler Co. customer service. See “Service Assistance” chapter.

Cleaning

- ▶ Clean surfaces with a lint-free cloth.

Installing the belt drive for the coolant pump and battery charging alternator

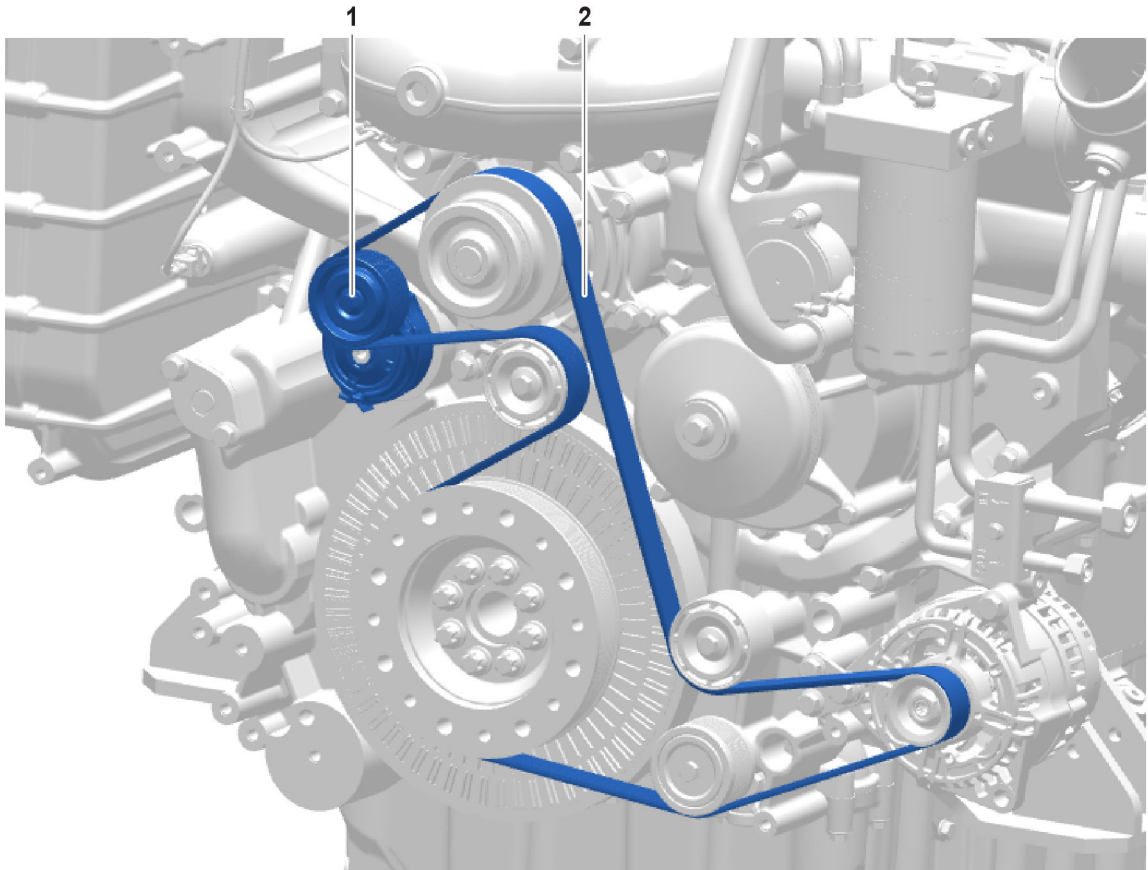

Fig. 55: Installing the V-ribbed belt

1 Tension pulley (self-tensioning)

2 V-ribbed belt

- ▶ Turn tension pulley (self-tensioning) **1** counterclockwise against the spring force to the limit stop.
- ▶ With the tensioning device pivoted back, place new V-ribbed belt **2** on all belt pulleys and tension pulley (self-tensioning) **1**, making sure that it is properly seated.

- ▶ Turn tension pulley (self-tensioning) **1** carefully to original position.
 - ▷ V-ribbed belt **2** is tensioned.
- ▶ Install V-ribbed belt for crankcase breather system (→ [5.4.6 Replacing the crankcase breather system V-ribbed belt – SL1-1662, p. 87](#)).

5.7 4000 - Fuel system

5.7.1 Checking the fuel level and checking / draining the water separator on the primary fuel filter – SL0-4011

Make sure that the following prerequisite is met:

- A collection container with the required capacity is available.

The primary fuel filter with water separator and manual fuel feed pump is some distance from the engine and is attached differently depending on the device design.



WARNING

Open flames!

Injuries, fire and explosion! Can cause severe injury or death.

- ▶ Avoid open flames or other ignition sources when performing maintenance or inspection work on the fuel system.
 - ▶ Perform maintenance and inspection work only when the engine has been turned off.
-

- ▶ Check water separator on primary fuel filter, see documentation for the generator set.

If there is water in the water separator:

- ▶ Drain the water.

5.7.2 Replacing the fuel prefilter – SL1-4110

Make sure that the following prerequisites are met:

- A collection container with the required capacity is available.
- A primary fuel filter insert is available.

For procedure to replace the primary fuel filter, see operation and maintenance manual for the generator set.



WARNING

Open flames!

Injuries, fire and explosion! Can cause severe injury or death.

- ▶ Avoid open flames or other ignition sources when performing maintenance or inspection work on the fuel system.
 - ▶ Perform maintenance and inspection work only when the engine has been turned off.
-

5.7.3 Replacing the main fuel filter – SL1-4120

Make sure that the following prerequisites are met:

- A collection container is available.
- The main fuel filter is on hand.
- Strap wrench or similar tool is on hand.

**WARNING**

Open flames!

Injuries, fire and explosion! Can cause severe injury or death.

- ▶ Avoid open flames or other ignition sources when performing maintenance or inspection work on the fuel system.
- ▶ Perform maintenance and inspection work only when the engine has been turned off.

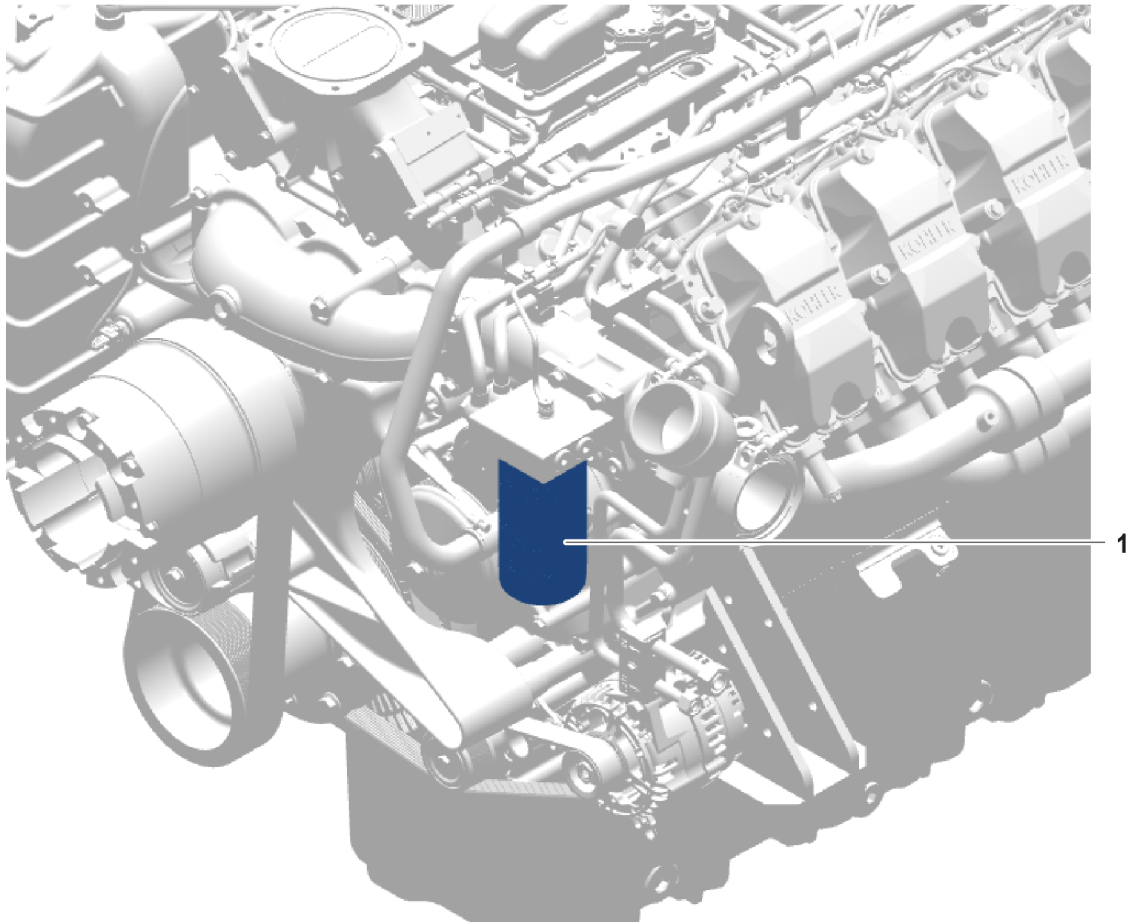

Fig. 56: Replacing the main fuel filter

1 Main fuel filter

- ▶ Place collection container under main fuel filter.
- ▶ Clean the main fuel filter and surrounding area carefully.
- ▶ Loosen the main fuel filter **1** with a strap wrench or similar tool and unscrew.
- ▶ Dispose of used main fuel filter (observe country-specific regulations).
- ▶ Check that the filter module is clean and make sure that the thread adapter fits firmly in the filter module.

If the filter module is dirty:

- ▶ Clean filter module.



Information

Dirt!

Destruction of the common rail system.

- ▶ Make sure that no dirt enters the clean side of the filter.
- ▶ Leave residual diesel fuel in the filter housing.
- ▶ Never reuse a main fuel filter after it has been used once.
- ▶ Pay attention to the special instructions for working on the common rail system, see “Safety instructions” chapter.

- ▶ Coat sealing ring on main fuel filter with lubricating oil.
- ▶ Screw in new main fuel filter until sealing ring rests against filter module.

Tightening instruction for main fuel filter	
Lubricant	-
Threadlock	-
Component contact surfaces	Lubricating oil
Screws	-
Stage	Tightening torque
1.	Screw in by hand until seal is in place
2.	3/4 turn (22.5 Nm)

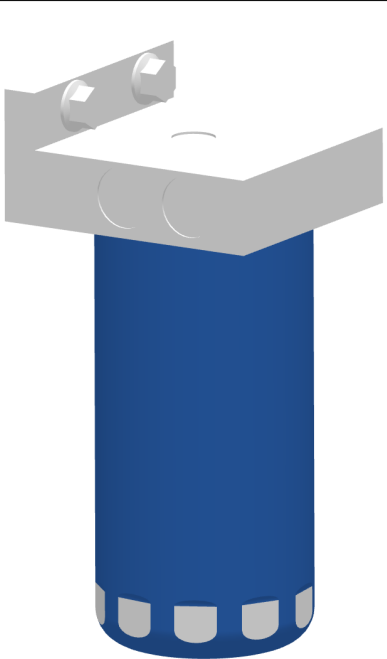

Tab. 44: Tightening instruction

- ▶ Tighten main fuel filter **1** according to tightening instruction.
- ▶ Vent fuel system.

5.8 5000 - Exhaust system and charge air system

5.8.1 Checking the exhaust system – SL1-5201

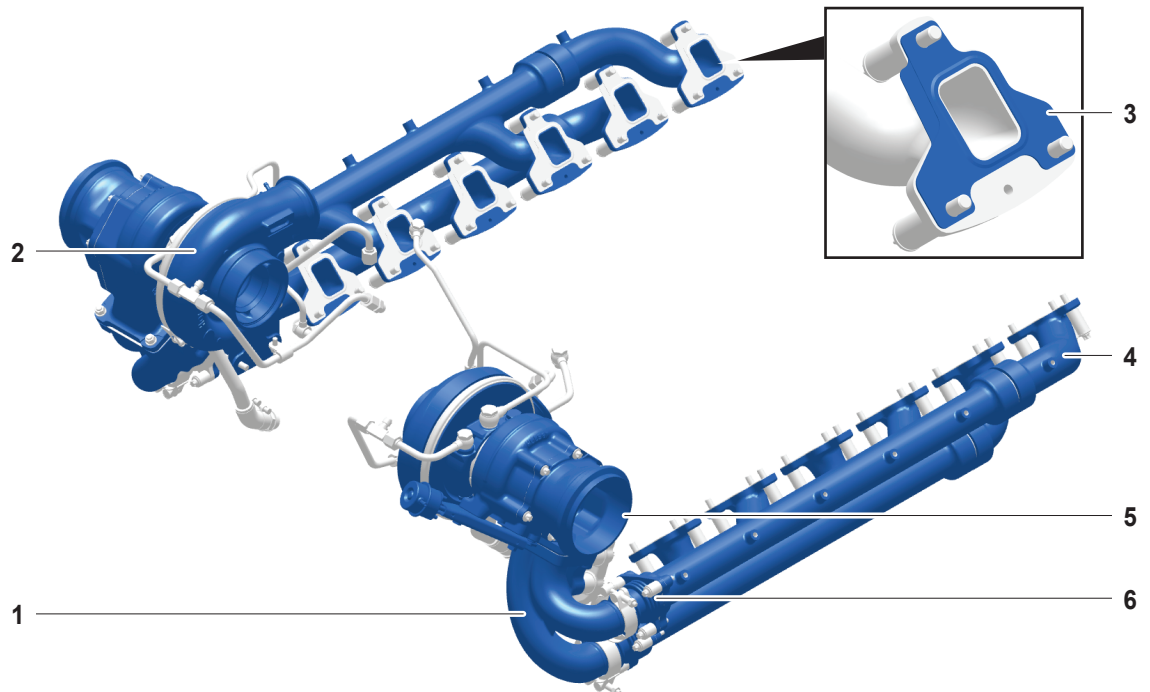

Fig. 58: Checking the exhaust system

- | | | | |
|---|--------------------------|---|--------------------|
| 1 | Exhaust pipe | 4 | Exhaust manifold |
| 2 | Exhaust gas turbocharger | 5 | Exhaust gas outlet |
| 3 | Gasket | 6 | Compensator |

► Check components for leaks.

If components are leaking:

- Do not start engine.
- Replace components, see repair instruction.
- Check components for proper fastening.

If components are loose:

- Do not start engine.
- Tighten components according to tightening instruction, see service and repair manual.
- Check components for damage.

If components are damaged:

- Do not start engine.
- Replace damaged components, see repair instructions.

5.8.2 Checking the exhaust gas aftertreatment system – SL0-5302

Make sure that the following prerequisites are met:

- Engine is turned off.
- Exhaust system has cooled down.

- ▶ Check overall condition of exhaust aftertreatment system.

Before starting the engine:

- ▶ Make sure that the diesel exhaust fluid tank is not clogged and the diesel exhaust fluid level is sufficient.
- ▶ Make sure that the diesel exhaust fluid line has no kinks, cracks, damage, or crystallization.
- ▶ Make sure that the wiring harness has no kinks, cracks or damage and that no connectors are loose.

During engine operation:

- ▶ Make sure that there is no error alarm or error code.
- ▶ Make sure that the diesel exhaust fluid line has no leaks.

After turning off the engine:



Information

Interruption of the power supply of the exhaust aftertreatment system by the user after turning off the engine!

Property damage due to impairment of the system cooling and draining process.

- ▶ Observe automatic cooling and flushing sequence after each shutdown.
- ▶ Wait for after-run procedure completion before switching off 28 V power source.

-
- ▶ Make sure that the power supply is not disconnected during the after-run process.

5.8.3 Replacing the diesel exhaust fluid filter – SL1-5320

Make sure that the following prerequisites are met:

- Preparatory maintenance work has been performed.
- New diesel exhaust fluid filter, new seals and filter clamp are available.
- Exhaust aftertreatment system is free and continuous.



Information

The activities are similar regardless of the number of diesel exhaust fluid filters.

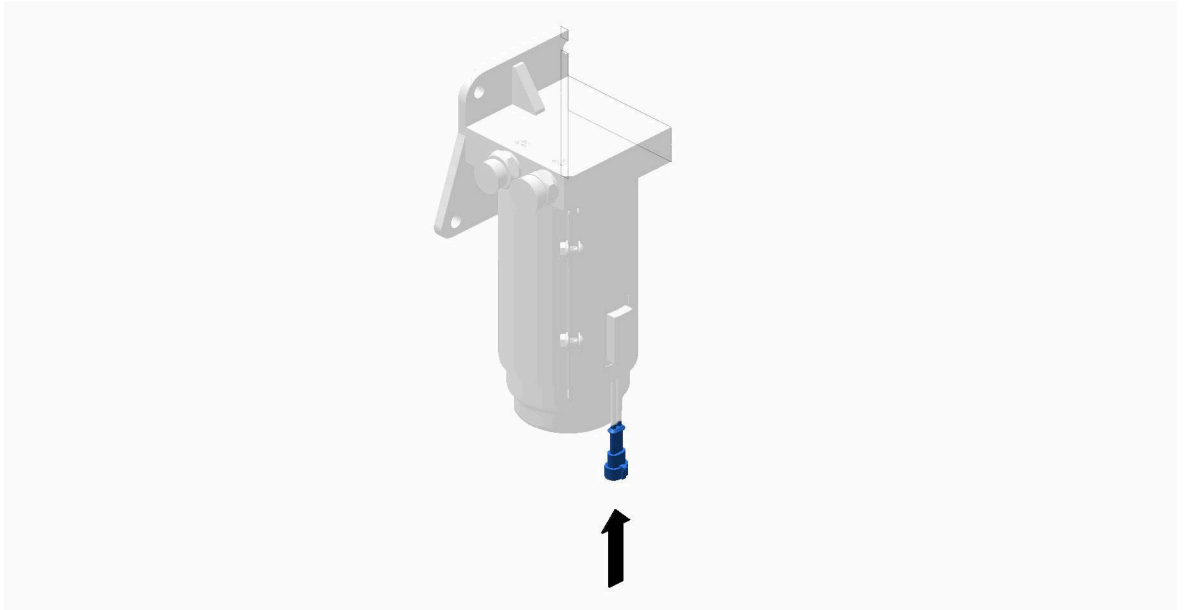

Fig. 59: Disconnecting the filter heating pad electric cable

- ▶ Disconnect filter heating pad electric cable.

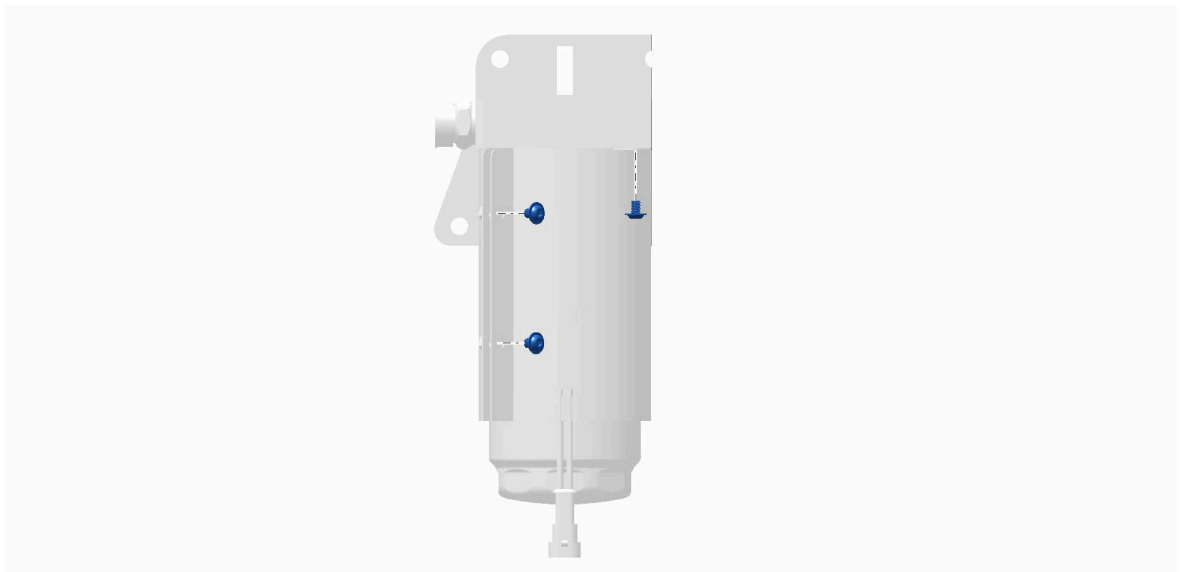

Fig. 60: Releasing the screws

- ▶ Release screws.

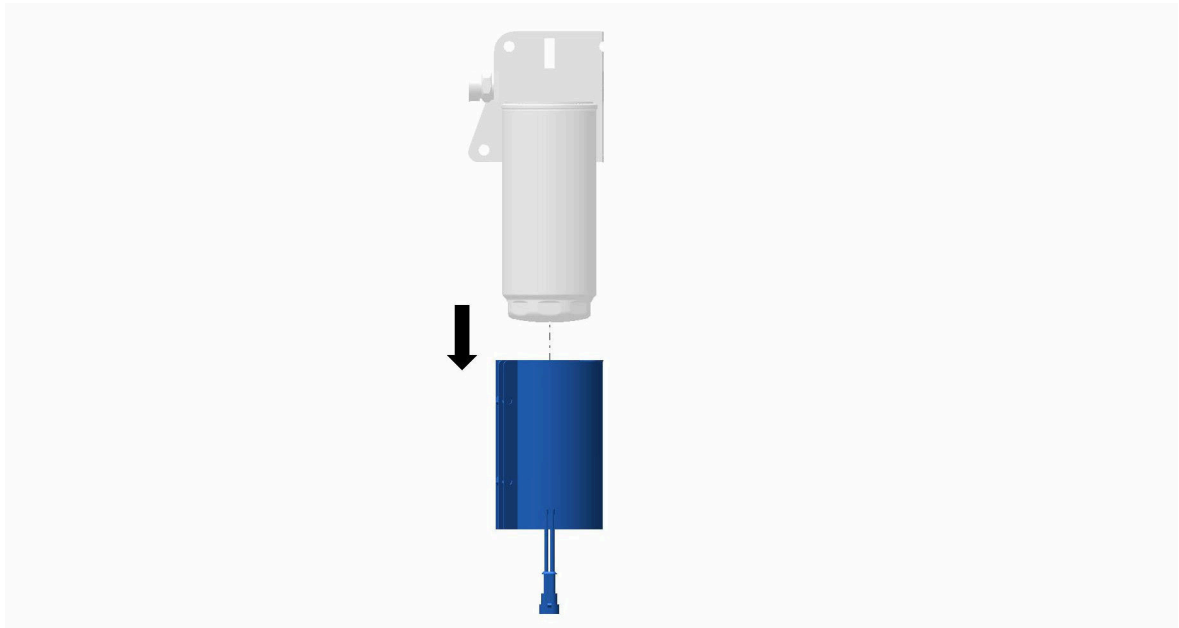

Fig. 61: Removing the heating pad

- ▶ Remove heating pad from filter.

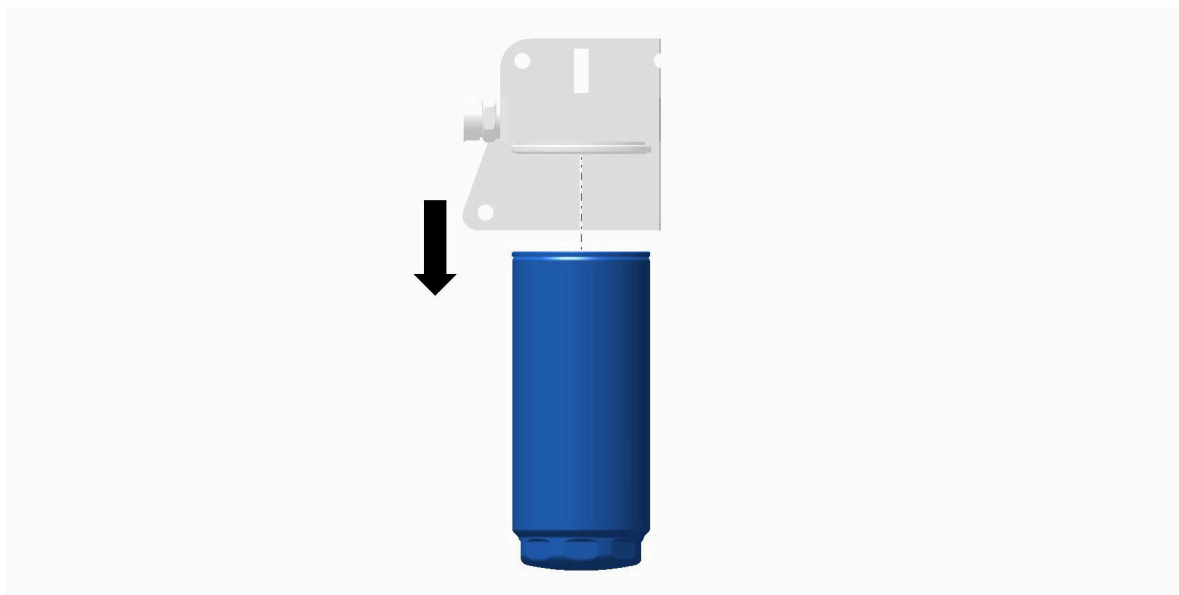

Fig. 62: Removing the filter

- ▶ Remove filter with a filter clamp.
- ▶ Remove seal from filter holder.

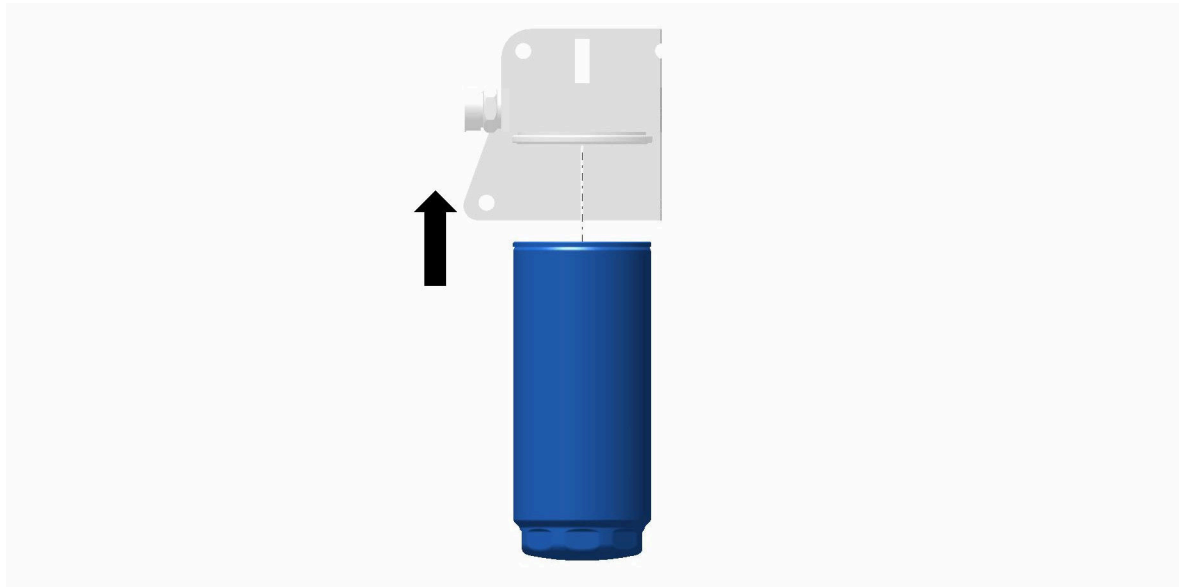

Fig. 63: Inserting the filter

- ▶ Coat new seal with diesel exhaust fluid.
- ▶ Install seal on filter holder.
- ▶ Fill new diesel exhaust fluid filter with 3/4 diesel exhaust fluid.



Information

Before installing the new diesel exhaust fluid filter, make sure that the surfaces have been cleaned.

- ▶ Install new diesel exhaust fluid filter.

Diesel exhaust fluid filter tightening instruction	
Lubricant	-
Threadlock	-
Component contact surfaces	-
Screws	-
Stage	Tightening torque
1.	Screw on by hand until seal is in place.
2.	35 ⁺⁵ Nm

Tab. 45: Tightening instruction

- ▶ Tighten diesel exhaust fluid filter according to tightening instruction.

or

Tighten diesel exhaust fluid filter by hand until it rests against the bracket and then tighten diesel exhaust fluid filter 120° with filter clamp.

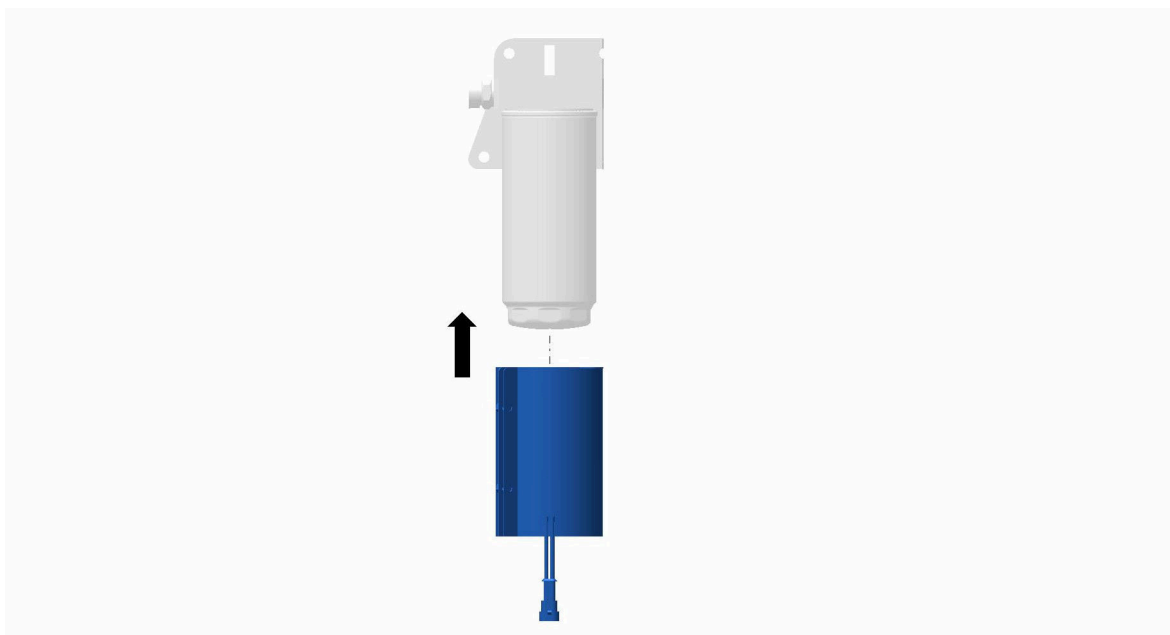

Fig. 64: Installing the heating pad

- ▶ Install heating pad on diesel exhaust fluid filter.

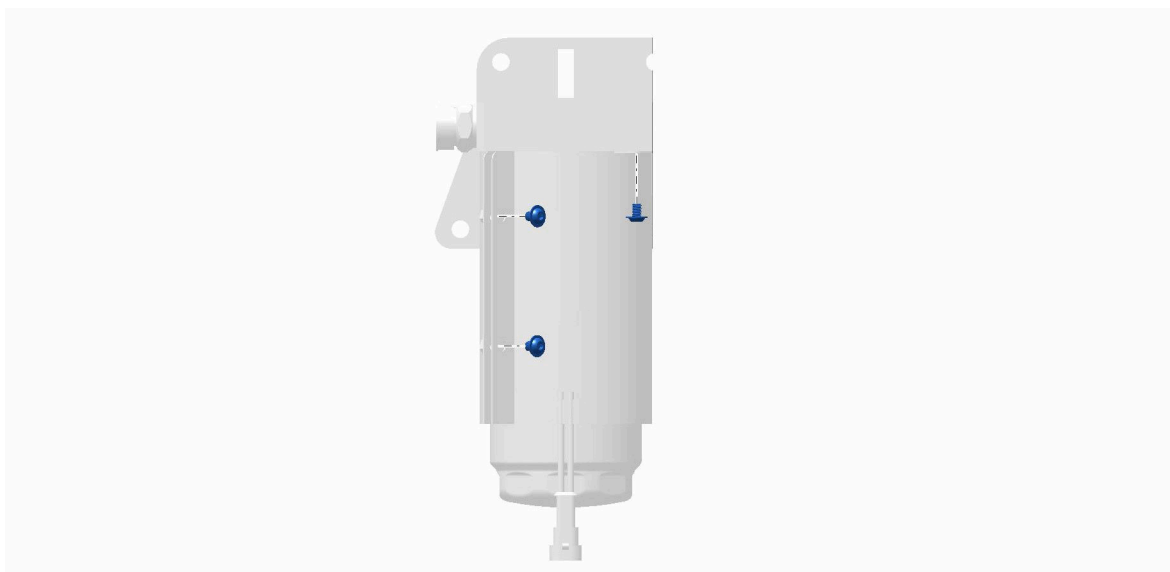

Fig. 65: Screwing in the heating pad screws

- ▶ Screw in heating pad screws.

Tightening instruction for heating pad screws	
Lubricant	-
Threadlock	-
Component contact surfaces	-
Screws	-
Stage	Tightening torque

Tightening instruction for heating pad screws		
1.	Screw on by hand until seal is in place.	
2.	6 ⁺¹ Nm	

Tab. 46: Tightening instruction

- ▶ Tighten screws according to tightening instruction.

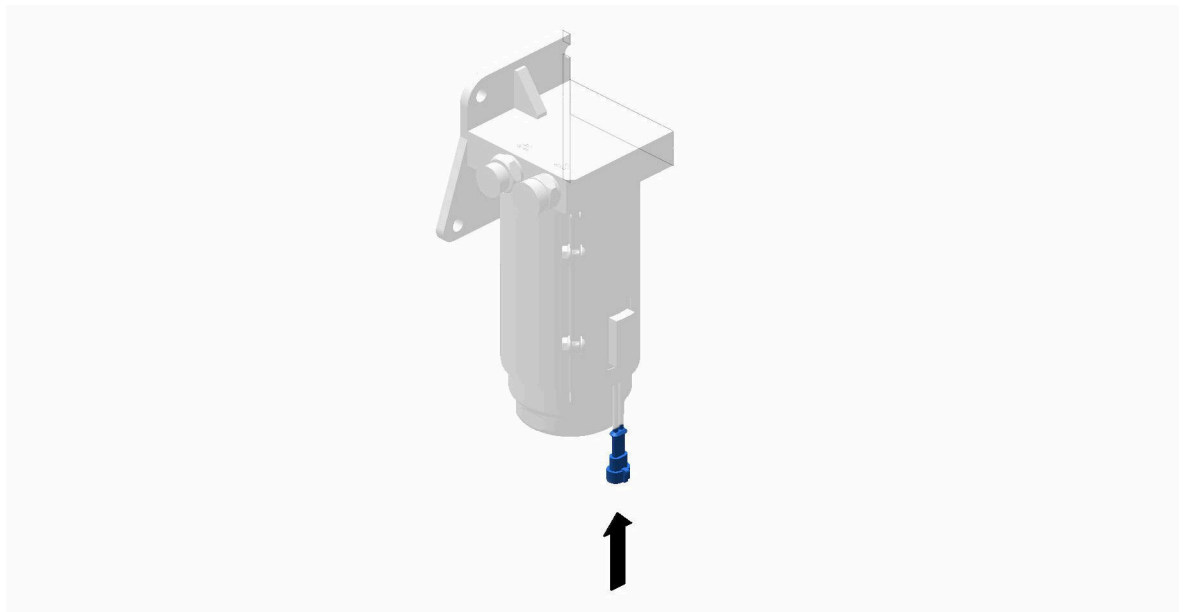

Fig. 66: Plugging in the connection for the heating pad

- ▶ Plug in electric cable for heating pad.
- ▶ Run engine for 30 minutes to ensure proper filling and no leaks.

5.8.4 Checking the exhaust gas turbocharger – SL1-5411

- ▶ Check exhaust gas turbocharger, see also ([→ 5.8.1 Checking the exhaust system – SL1-5201, p. 111](#))

- ▶ Check components for leaks.

If components are leaking:

- ▶ Do not start engine.
- ▶ Replace components, see repair instruction.
- ▶ Check components for proper fastening.

If components are loose:

- ▶ Do not start engine.
- ▶ Tighten components according to tightening instruction, see service and repair manual.
- ▶ Check components for damage.

If components are damaged:

- ▶ Do not start engine.
- ▶ Replace damaged components, see repair instructions.

5.9 7000 - Accessories

5.9.1 Checking the fan drive belt drive – SL1-7221

Damage to the V-ribbed belt includes:

- Broken ribs
- Rubber nodules in the base of the belt
- Dirt and/or stone deposits
- Ribs broken off the base of the belt
- Transverse cracks on the back
- Transverse cracks in several ribs

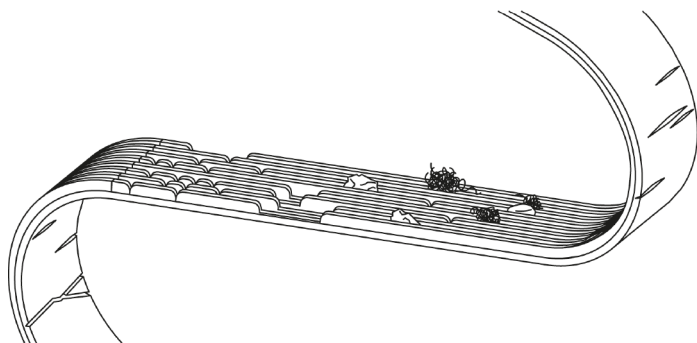

Fig. 67: Damage to the V-ribbed belt



WARNING

Rotating components!
Risk of injury. Can cause serious injuries.

- ▶ Turn off engine.
 - ▶ Secure the engine against unexpected start-up.
-

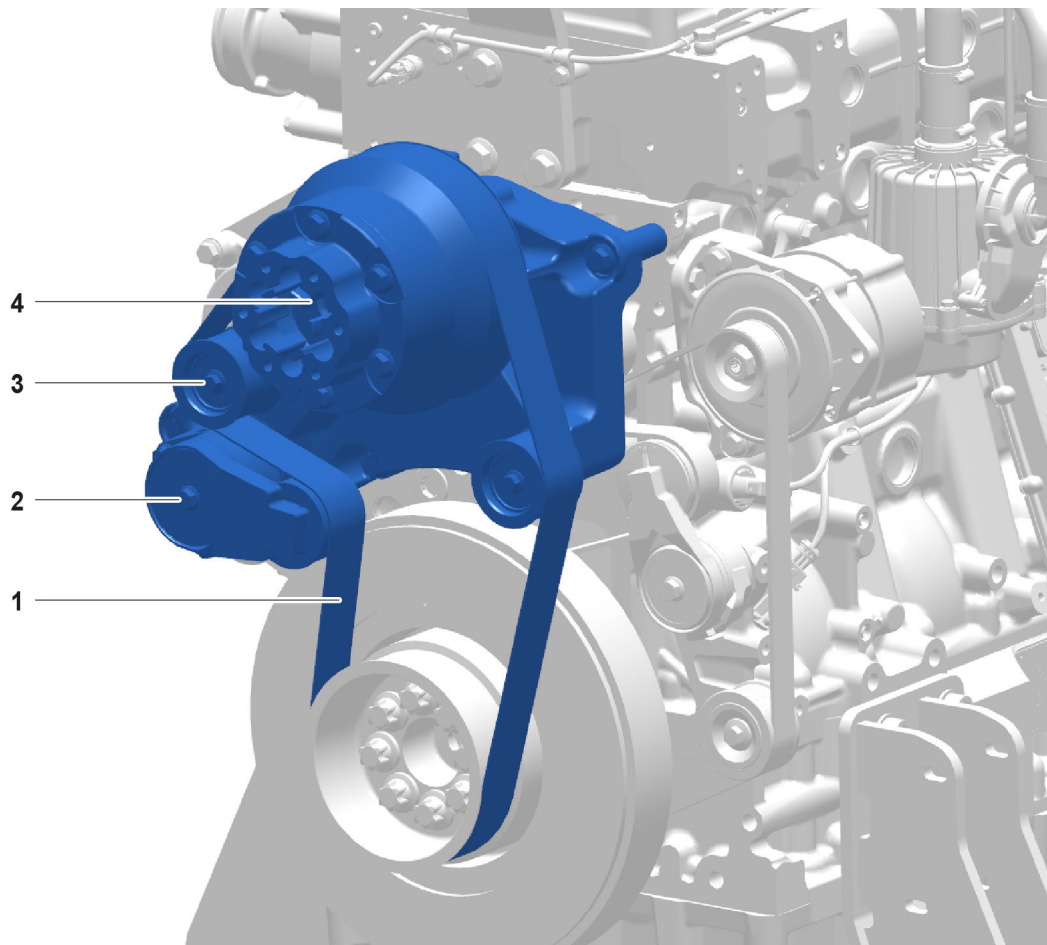

Fig. 68: Checking the fan drive belt drive

- 1** Fan drive V-ribbed belt
- 2** Tension pulley (self-tensioning)

- 3** Deflection pulley (2x)
- 4** Belt pulley

- ▶ Check fan drive V-ribbed belt **1** for damage.
- ▶ Check that the belt pulley **4** and tension pulley (self-tensioning) **2** are in perfect working order and check their play (for example, worn out bearings on deflection pulleys **3** or tread wear on belt pulley **4**).
- ▶ Replace damaged parts. Please contact the nearest authorized Kohler Co. customer service.

6 Transport and storage



DANGER

Protective atmosphere against oxidation damage inside the protective foil!
Risk of death, risk of suffocation. Can cause serious injuries or death.

- ▶ Remove and store protective foil only in well ventilated areas.
 - ▶ Protective foil must be stored in areas that are inaccessible to children.
-



CAUTION

Incorrect waste disposal!
Environmental and health hazards.

- ▶ Observe national and international guidelines for disposal of waste materials.
 - ▶ Dispose of all waste in appropriate containers.
 - ▶ Store waste in designated areas.
-

NOTICE

Incorrect setting down of the engine.
Engine damage.

- ▶ Do not place engine on oil pan.
 - ▶ Place engine on appropriate engine feet.
-

NOTICE

Improper storage.
Oxidation damage.

- ▶ Only store the engine in dry locations.
- ▶ Do not expose the engine to severe temperature fluctuations.
- ▶ Only remove the transport protective foil shortly before installation.

When the engine is removed:

- ▶ Apply new protective foil and observe climatic conditions for storage.
-



Information

Storage conditions are the responsibility of the system manufacturer.

- ▶ Observe standard ISO 6749-1984 for transport and storage.
 - ▶ In the event of uncertainties, contact Kohler customer service.
-



Information

The machine owner is responsible for observing the maximum floor load.

- ▶ Check maximum floor load before setting down the engine.
 - ▶ Weight data can be found in the technical data sheet.
-



Information

- ▶ Only use preservatives approved by Kohler Co.

6.1 Transport

6.1.1 Transport attachment



Fig. 69: Example of transport attachment



DANGER

Instability during transport!
Leads to death or serious injuries.

- ▶ Only use the original transport device.
- ▶ Secure the transport device, including the mounted engine, against slipping and falling down.
- ▶ Make sure that transport device is in technically perfect condition.
- ▶ Secure the transport device against slipping and falling down in all directions.
- ▶ Observe the center of gravity.
- ▶ Bolt engine securely to transport device.



DANGER

Tipping of engine during loading or unloading!
Leads to death or serious injuries.

- ▶ Make sure that only authorized personnel load/unload the engine.
- ▶ Make sure that the crane or forklift is suitable for the weight to be lifted.

If the engine is being lifted with a crane:

- ▶ Use a lifting traverse.
- ▶ Make sure that no persons reside in the danger zone during the loading / unloading.
- ▶ Observe information on the center of gravity.

6.1.2 Wood transport device



Fig. 70: Wood transport device



DANGER

Instability during transport!
Leads to death or serious injuries.

- ▶ Only use the original transport device.
- ▶ Secure the transport device, including the mounted engine, against slipping and falling down.
- ▶ Make sure that transport device is in technically perfect condition.
- ▶ Secure the transport device against slipping and falling down in all directions.
- ▶ Observe the center of gravity.
- ▶ Bolt engine securely to transport device.



Information

- ▶ Wood transport devices do not need to be returned to Kohler Co. Keep for later use.

6.2 Storage

6.2.1 Storage for up to 6 months

The engine is conserved as of the date it is ready for delivery; for normal storage in a dry, ventilated place, the duration of the conservation protection is 6 months.

If the engine is additionally covered with a film cover, it can even be situated outdoors for up to one month.

The cover must be waterproof and lie loosely against the engine so that the air can circulate around the engine and the formation of condensation is prevented.

If the aforementioned stipulations are deviated from, in which the conserved engine is subjected to more unfavorable conditions (longer placement outdoors or storage in damp, unventilated places etc.), a shortening of the duration of the conservation protection is to be expected.

6.2.2 Storage for over 6 and up to 24 months

Please contact Field Service if planning storage over 6 months up to 24 months.

7 Tools and devices

7.1 Tools

7.1.1 Special tools for maintenance tasks

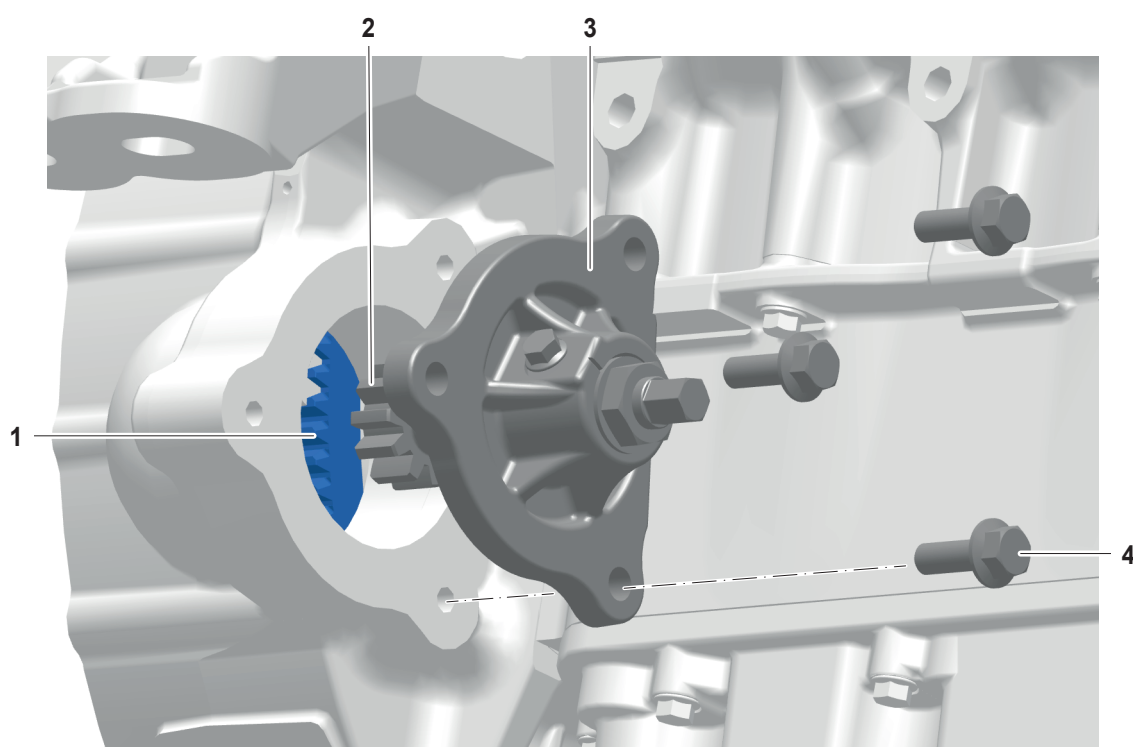

Fig. 71: Turning device

- 1** Flywheel gearing
2 Turning device gearing

- 3** Turning device
4 M12x35 hex head screw (3x)

ID no.	Name
10123791	Turning device

Tab. 47

8 Standard torques

8.1 Tightening torques

8.1.1 Hex head screws / hexagon socket screws / hexalobular flange head screws

The standard tightening torques listed apply to screws with standard threads. A specific tightening instruction is specified for screws used with fine threads.

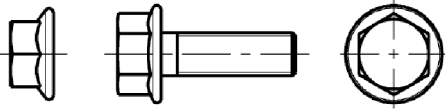
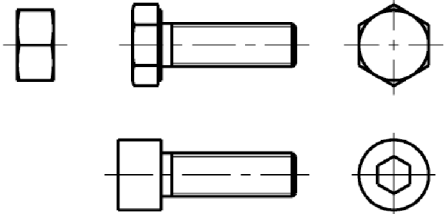
Head shape or shape of the screws and nuts	Surface treatment
	All screws and nuts
	All screws and nuts except FLZN/480H (matte gray)

Tab. 48: Screw types

Standard thread	Tightening torque	
	8.8	10.9
Strength class		
M4	3 Nm	4 Nm
M5	6 Nm	8 Nm
M6	10 Nm	14 Nm
M8	23 Nm	34 Nm
M10	46 Nm	68 Nm
M12	79 Nm	117 Nm
M14	125 Nm	185 Nm
M16	195 Nm	280 Nm
M18	280 Nm	390 Nm
M20	390 Nm	560 Nm

Tab. 49: Tightening torques for metric standard thread

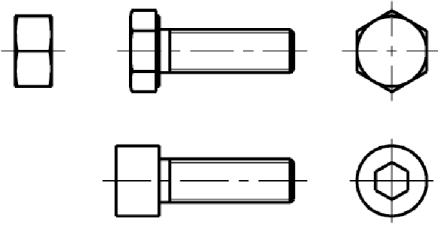
Head shape or shape of the screws and nuts	Surface treatment
	FLZN/480H (matte gray)

Tab. 50: Screw types

Standard thread	Tightening torque	
	8.8	10.9
Strength class		
M4	2.4 Nm	3.6 Nm
M5	4.8 Nm	7 Nm
M6	8.3 Nm	12 Nm
M8	20 Nm	29 Nm
M10	40 Nm	59 Nm
M12	69 Nm	101 Nm
M14	110 Nm	161 Nm
M16	166 Nm	244 Nm
M18	240 Nm	340 Nm
M20	335 Nm	480 Nm

Tab. 51: Tightening torques for metric standard thread

8.1.2 High temperature screws

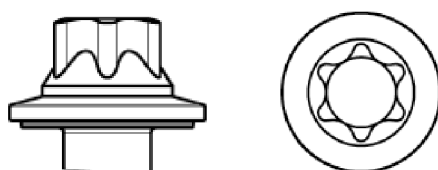

Fig. 75: High temperature screws

High temperature screws with special markings and screw heads according to DIN 34801.

Standard thread	Tightening torque		
	GA	SD	VW
Marking			
M6	9 Nm	10 Nm	13 Nm
M8	23 Nm	25 Nm	30 Nm
M10	45 Nm	50 Nm	60 Nm

Standard thread	Tightening torque		
M12	75 Nm	85 Nm	100 Nm

Tab. 52: Tightening torques for high temperature screws

8.1.3 Screw plugs and banjo bolts with separate seal

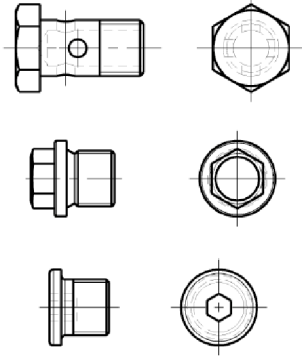

Fig. 76: Screw plugs and banjo bolts

Screw plugs according to DIN 908

Banjo bolts according to DIN 7643

Screw plugs and banjo bolts with copper seal according to DIN 7603 or BS sealing ring

Standard thread	Tightening torque	Standard thread	Tightening torque
M6	7 Nm	M24	68 Nm
M8	7.5 Nm	M26	75 Nm
M10	15 Nm	M27	87 Nm
M12	20 Nm	M30	115 Nm
M14	30 Nm	M33	120 Nm
M16	40 Nm	M36	155 Nm
M18	40 Nm	M38	171 Nm
M20	47 Nm	M39	215 Nm
M22	57 Nm	M42	240 Nm

Tab. 53: Tightening torques for screw plugs and banjo bolts

8.1.4 VSTI screw plugs

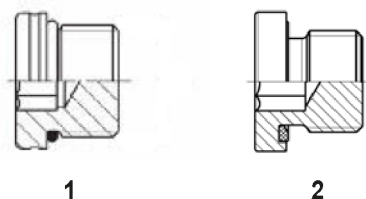

Fig. 77: VSTI screw plugs

- 1** Screw plug with o-ring **2** Screw plug with ED seal

Standard thread	Tightening torque	Standard thread	Tightening torque
M10 x 1	10 Nm	M26 x 1.5	100 Nm
M12 x 1.5	20 Nm	M27 x 2	120 Nm
M14 x 1.5	30 Nm	M30 x 1.5	120 Nm
M16 x 1.5	40 Nm	M33 x 2	200 Nm
M18 x 1.5	50 Nm	M38 x 1.5	280 Nm
M20 x 1.5	60 Nm	M42 x 2	350 Nm
M22 x 1.5	80 Nm	M48 x 2	400 Nm
M24 x 1.5	90 Nm		

Tab. 54: Tightening torques for VSTI screw plugs

8.1.5 Threaded union for steel or cast iron mating materials

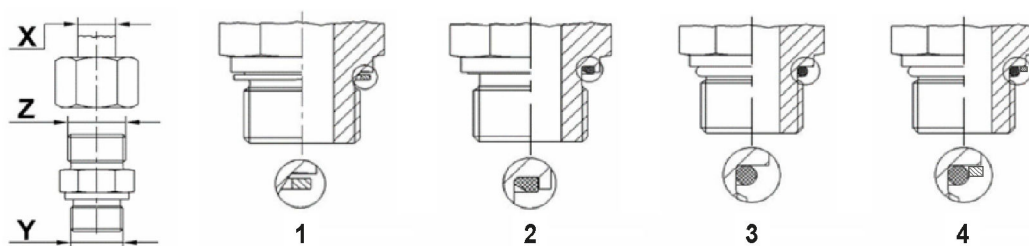

Fig. 78: Overview of threaded union

- 1** Form A - With sealing ring (washer) **3** Form F - O-ring
2 Form E - Flat (ED) seal **4** Form F - O-ring plus washer



Information

Tightening torques apply for steel or cast iron mating materials.

- ▶ For screw-in studs in stainless steel, lubricate thread with new engine oil before screwing in.
- ▶ Define series L or S through dimensioning of pipe diameter X and thread Y.

Metric screw fittings series L (light)

Pipe diameter X	Thread Y	Form A with sealing ring (washer)	Form E with flat (ED) seal	Form F with o- ring	Form F with o- ring plus washer
		Tightening torque			
6 mm	M10 x 1.0	9 Nm	18 Nm	15 Nm	18 Nm
8 mm	M12 x 1.5	20 Nm	25 Nm	25 Nm	35 Nm
10 mm	M14 x 1.5	35 Nm	45 Nm	35 Nm	45 Nm
12 mm	M16 x 1.5	45 Nm	55 Nm	40 Nm	55 Nm
15 mm	M18 x 1.5	55 Nm	70 Nm	45 Nm	70 Nm
18 mm	M22 x 1.5	65 Nm	125 Nm	60 Nm	180 Nm
22 mm	M26 x 1.5	90 Nm	180 Nm	100 Nm	250 Nm
28 mm	M33 x 2.0	150 Nm	310 Nm	160 Nm	310 Nm
35 mm	M42 x 2.0	240 Nm	450 Nm	210 Nm	450 Nm
42 mm	M48 x 2.0	290 Nm	540 Nm	260 Nm	540 Nm

Tab. 55: Tightening torques for metric screw fittings series L (light)

Metric screw fittings series S (heavy)

Pipe diameter X	Thread Y	Form A with sealing ring (washer)	Form E with flat (ED) seal	Form F with o- ring	Form F with o- ring plus washer
		Tightening torque			
6 mm	M10 x 1.0	-	23 Nm	-	-
6 mm	M12 x 1.5	20 Nm	40 Nm	35 Nm	35 Nm
8 mm	M14 x 1.5	35 Nm	40 Nm	45 Nm	60 Nm
10 mm	M16 x 1.5	45 Nm	70 Nm	55 Nm	95 Nm
12 mm	M18 x 1.5	55 Nm	90 Nm	70 Nm	120 Nm
14 mm	M20 x 1.5	55 Nm	125 Nm	80 Nm	-
16 mm	M22 x 1.5	65 Nm	135 Nm	100 Nm	190 Nm
20 mm	M27 x 2.0	90 Nm	180 Nm	170 Nm	190 Nm
25 mm	M33 x 2.0	150 Nm	310 Nm	310 Nm	500 Nm
30 mm	M42 x 2.0	240 Nm	450 Nm	330 Nm	600 Nm
38 mm	M48 x 2.0	290 Nm	540 Nm	420 Nm	600 Nm

Tab. 56: Tightening torques for metric screw fittings series S (heavy)

8.1.6 Threaded union for aluminum mating material

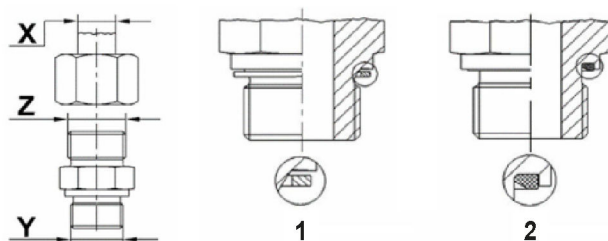

Fig. 79: Overview of threaded union

1 Form A - With sealing ring (washer)

2 Form E - Flat (ED) seal



Information

Tightening torques apply for aluminum mating material.

► For screw-in studs in stainless steel, lubricate thread with new engine oil before screwing in.

Metric screw fittings series L (light) for aluminum

Pipe diameter X	Thread Y	Form A with sealing ring (washer)	Form E with flat (ED) seal
		Tightening torque	
6 mm	M10 x 1.0	15 Nm	12 Nm
8 mm	M12 x 1.5	-	20 Nm
10 mm	M14 x 1.5	30 Nm	30 Nm
12 mm	M16 x 1.5	40 Nm	40 Nm
15 mm	M18 x 1.5	-	50 Nm
18 mm	M22 x 1.5	80 Nm	90 Nm
22 mm	M26 x 1.5	80 Nm	130 Nm
28 mm	M30 x 1.5	-	180 Nm
28 mm	M33 x 2.0	-	220 Nm
35 mm	M42 x 2.0	-	320 Nm
42 mm	M48 x 2.0	-	380 Nm

Tab. 57: Tightening torques for metric screw fittings series L for aluminum

8.1.7 Nut for cutting ring screw fittings

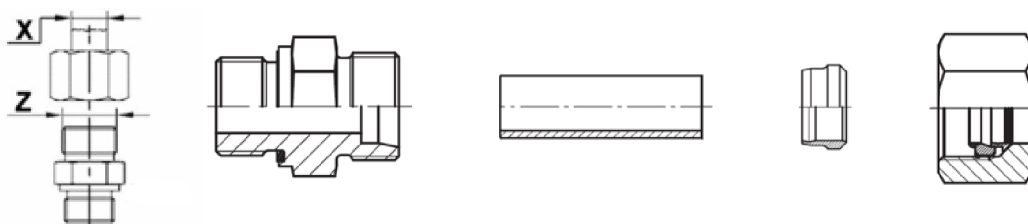

Fig. 80: Cutting ring screw fittings

Series	Pipe diameter X	Standard thread Z	Tightening torque
LL	6 mm	M10 x 1	14 Nm
L	6 mm	M12 x 1.5	14 Nm
	8 mm	M14 x 1.5	20 Nm
	10 mm	M16 x 1.5	30 Nm
	12 mm	M18 x 1.5	60 Nm
	15 mm	M22 x 1.5	105 Nm
	18 mm	M26 x 1.5	150 Nm
	22 mm	M30 x 2	200 Nm
	28 mm	M36 x 2	250 Nm
	35 mm	M45 x 2	450 Nm
S	42 mm	M52 x 2	600 Nm
	16 mm	M24 x 1.5	150 Nm
	20 mm	M30 x 2	250 Nm
	25 mm	M36 x 2	450 Nm
	30 mm	M45 x 2	600 Nm
	38 mm	M52 x 2	750 Nm

Tab. 58: Tightening torques for cutting ring screw fittings

8.1.8 Nut for Triple Lok® screw fittings

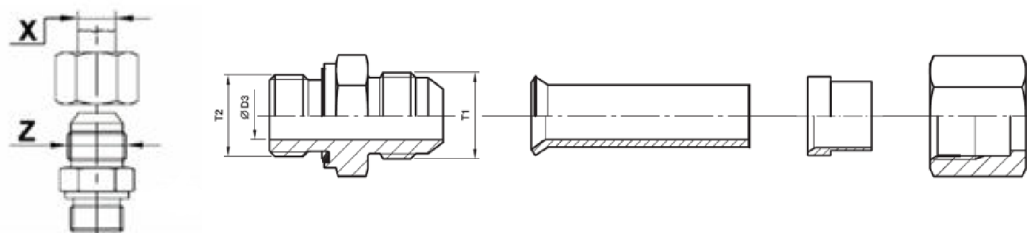

Fig. 81: Triple Lok® screw fittings



Information

- For stainless steel threaded unions, lubricate thread and sealing cone with new engine oil before screwing in.

Series	Pipe diameter X	Standard thread Z	Steel	Stainless steel
		UN/UNF	Tightening torque	
4	6 mm	7/17-20	15 Nm	30 Nm
5	8 mm	1/2-20	20 Nm	40 Nm
6	10 mm	9/16-18	30 Nm	60 Nm
8	12 mm	3/4-16	60 Nm	115 Nm
10	14 mm 15 mm 16 mm	7/8-14	75 Nm	145 Nm
12	18 mm 20 mm	1 1/16-12	110 Nm	180 Nm
16	22 mm	1 5/16-12	135 Nm	225 Nm
	25 mm	1 5/16-12	175 Nm	255 Nm
	28 mm	1 5/8-12	260 Nm	295 Nm
20	30 mm 32 mm	1 5/8-12	260 Nm	295 Nm
	35 mm	1 7/8-12	340 Nm	345 Nm
24	38 mm	1 7/8-12	340 Nm	345 Nm
28	42 mm	2 1/4-12	380 Nm	400 Nm
32	50 mm	2 1/2-12	450 Nm	470 Nm

Tab. 59: Tightening torques for Triple Lok® screw fittings

8.1.9 Threaded union for plastic quick couplings

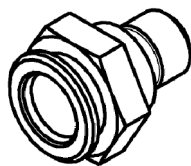

Fig. 82: Threaded union for plastic quick couplings

Standard thread	Tightening torque
M8 x 1	7 Nm
M10 x 1	12 Nm
M12 x 1.5	20 Nm
M14 x 1.5	30 Nm
M16 x 1.5	35 Nm
M18 x 1.5	45 Nm

Tab. 60: Tightening torques for threaded union for plastic quick couplings

8.1.10 Stud bolts

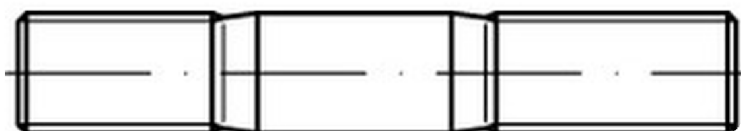

Fig. 83: Stud bolts

Standard thread	Tightening torque
M6	5 Nm
M8	10 Nm
≥M10	15 Nm

Tab. 61: Tightening torques for stud bolts

8.1.11 Pipe clamp on fuel lines

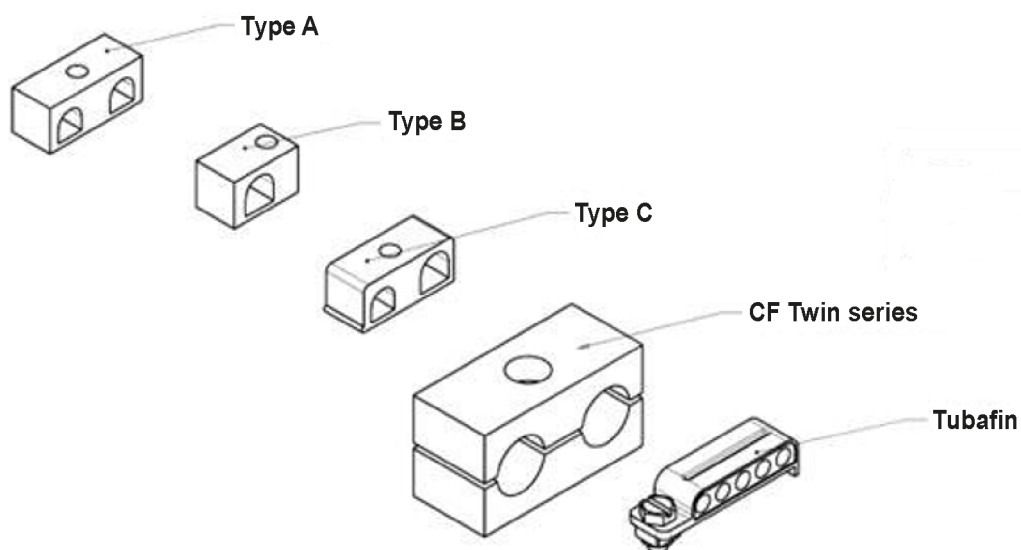

Fig. 84: Pipe clamps on fuel lines

Standard thread	Type A,B,C	CF Twin series	Tubafin
M6	6 Nm	6 Nm	5 Nm
M8	-	13 Nm ($\varnothing \geq 30$ mm)	-
M8	-	9 Nm ($\varnothing \leq 30$ mm)	-

Tab. 62: Tightening torques for pipe clamps on fuel lines

8.1.12 Hose clamp

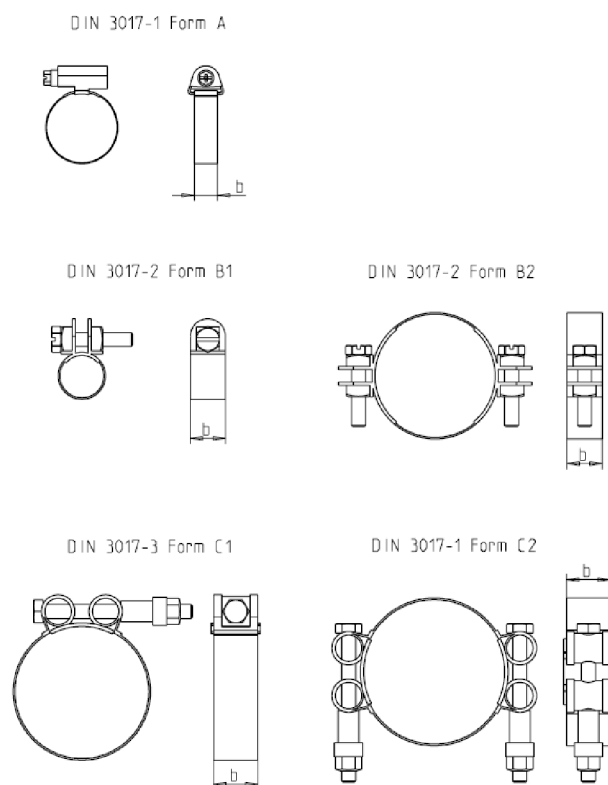

Fig. 85: Hose clamps

Width (b)	DIN 3017-1	DIN 3017-2	DIN 3017-3
5 mm	0.3 Nm	-	-
7 mm	-	0.5 Nm	-
7.5 mm	1.5 Nm	-	-
9 mm	3 Nm	1.2 Nm	-
12 mm	-	1.5 Nm	-
13 mm	5 Nm	-	-
15 mm	-	4 Nm	2 Nm
18 mm	-	-	4 Nm
20 mm	-	12 Nm	7 Nm
25 mm	-	30 Nm	12 Nm
30 mm	-	70 Nm	30 Nm

Tab. 63: Tightening torques for hose clamps

8.1.13 V-band clamp on charge air pipes and rubber connections

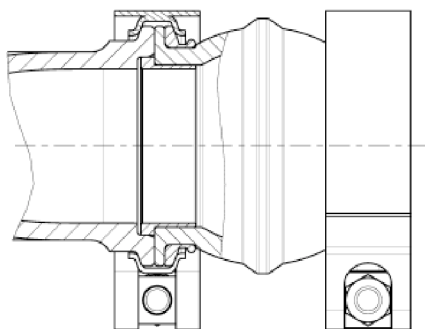

Fig. 86: V-band clamp on charge air pipes and rubber connections

Standard thread	Tightening torque
M8	12 ^{±1} Nm

Tab. 64: Tightening torque for V-band clamp on charge air pipes and rubber connections

8.1.14 V-band clamp with seal or o-ring

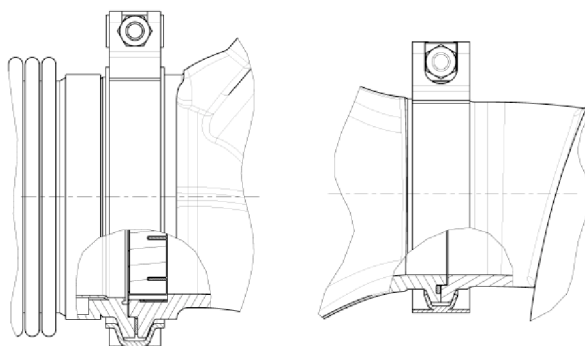

Fig. 87: V-band clamp with seal or o-ring

Standard thread	Tightening torque
M8	18 ^{±1} Nm

Tab. 65: Tightening torque for V-band clamp with seal or o-ring

8.2 Error code



Information

Error code list extracted from ECU software version 21.16.30 and dataset revision 1.

The following error code table is indicative. Refer to the technical data sheet of your engine for the latest software version.

For further information, please contact your nearest authorized Kohler service representative.

Abbreviations:

- SPN - Suspect Parameter Number
- FMI - Failure mode identification

SPN	FMI	Designation
94	0	Fuel supply - Critical overpressure
94	1	Fuel supply - Critical underpressure
94	3	Fuel supply pressure sensor - Short circuit to battery
94	4	Fuel supply pressure sensor - Short circuit to ground or open circuit
94	31	Fuel supply pressure sensor - Supply voltage out of range
97	5	P2264-13 Water in fuel sensor - Open circuit
97	5	Water in fuel sensor - Open circuit
97	11	Water in fuel sensor - Out of range
97	3	Water in fuel sensor - Short circuit to battery
97	4	Water in fuel sensor - Short circuit to ground
97	31	Water in fuel sensor - Supply voltage out of range
97	11	Water in fuel sensor - Value out of range
97	0	Water in fuel sensor - Water in fuel detected
100	1	Engine oil - Critical underpressure
100	2	Engine oil - Plausibility error
100	17	Engine oil - Underpressure warning
100	2	Engine oil Pressure - Plausibility error
100	3	Oil pressure sensor - Short circuit to battery
100	4	Oil pressure sensor - Short circuit to ground or open circuit
100	31	Oil pressure sensor - Supply voltage out of range
101	0	Crankcase pressure - Critical overpressure
101	15	Crankcase pressure - Overpressure warning
101	31	Crankcase pressure - Supply voltage out of range
101	3	Crankcase pressure sensor - Short circuit to battery
101	4	Crankcase pressure sensor - Short circuit to ground or open circuit

SPN	FMI	Designation
102	0	Intake manifold - Critical overpressure
102	1	Intake manifold - Critical underpressure
102	15	Intake manifold - Overpressure warning
102	17	Intake manifold - Underpressure warning
102	3	Intake manifold pressure sensor - Short circuit to battery
102	4	Intake manifold pressure sensor - Short circuit to ground or open circuit
102	31	Intake manifold pressure sensor - Supply voltage out of range
105	5	Intake air temperature sensor - Open circuit
105	3	Intake air temperature sensor - Short circuit to battery
105	4	Intake air temperature sensor - Short circuit to ground
105	31	Intake air temperature sensor - Supply voltage out of range
105	0	Intake manifold - Critical overtemperature
105	15	Intake manifold - Overtemperature warning
105	5	Intake manifold temperature sensor - Open circuit
105	3	Intake manifold temperature sensor - Short circuit to battery
105	4	Intake manifold temperature sensor - Short circuit to ground
105	31	Intake manifold temperature sensor - Supply voltage out of range
107	0	Air filter - Blocked / Clogged
107	11	Air filter - Blocked / Clogged
107	31	Air filter pressure switch - Supply voltage out of range
108	3	Ambient pressure sensor - Short circuit to battery
108	30	Ambient pressure sensor - Short circuit to ground or open circuit
108	31	Ambient pressure sensor - Supply voltage out of range
110	5	Coolant temperature sensor - Open circuit
110	3	Coolant temperature sensor - Short circuit to battery
110	4	Coolant temperature sensor - Short circuit to ground
110	31	Coolant temperature sensor - Supply voltage out of range
110	0	Engine coolant - Critical overtemperature
110	15	Engine coolant - Overtemperature warning
111	3	Coolant level sensor - Short circuit to battery
111	4	Coolant level sensor - Short circuit to ground or open circuit
111	31	Coolant level sensor - Supply voltage out of range
111	11	Coolant level sensor - Value out of range
111	1	Engine coolant - Level low
111	17	Engine coolant - Level low

Standard torques

Error code

SPN	FMI	Designation
157	0	Common rail - Critical overpressure
157	15	Common rail - Overpressure warning
157	3	Common rail pressure sensor - Short circuit to battery or open circuit
157	4	Common rail pressure sensor - Short circuit to ground
157	31	Common rail pressure sensor - Supply voltage out of range
171	5	Ambient temperature sensor - Open circuit
171	3	Ambient temperature sensor - Short circuit to battery
171	4	Ambient temperature sensor - Short circuit to ground
171	31	Ambient temperature sensor - Supply voltage out of range
174	0	Fuel supply - Critical overtemperature
174	15	Fuel supply - Overtemperature warning
174	5	Fuel temperature sensor - Open circuit
174	3	Fuel temperature sensor - Short circuit to battery
174	4	Fuel temperature sensor - Short circuit to ground
174	31	Fuel temperature sensor - Supply voltage out of range
175	0	Engine oil - Critical overtemperature
175	15	Engine oil - Overtemperature warning
175	5	Oil temperature sensor - Open circuit
175	3	Oil temperature sensor - Short circuit to battery
175	4	Oil temperature sensor - Short circuit to ground
175	4	Oil temperature sensor - Short circuit to ground or open circuit
175	31	Oil temperature sensor - Supply voltage out of range
190	2	Crankshaft position - Plausibility error
190	14	Crankshaft position sensor - Ground error
190	5	Crankshaft position sensor - Open circuit
190	3	Crankshaft position sensor - Short circuit to battery or open circuit
190	4	Crankshaft position sensor - Short circuit to ground
190	31	Crankshaft position sensor - Supply voltage out of range
190	0	Genset - Engine over speed
625	5	Engine Control Unit CAN 2 - Open circuit
625	11	Engine Control Unit CAN 2 - Short circuit
636	2	Camshaft position - Plausibility error
636	14	Camshaft position sensor - Ground error
636	5	Camshaft position sensor - Open circuit
636	3	Camshaft position sensor - Short circuit to battery

SPN	FMI	Designation
636	3	Camshaft position sensor - Short circuit to battery or open circuit
636	4	Camshaft position sensor - Short circuit to ground
636	31	Camshaft position sensor - Supply voltage out of range
637	2	Crankshaft position - Plausibility error
637	14	Crankshaft position sensor - Ground error
637	5	Crankshaft position sensor - Open circuit
637	3	Crankshaft position sensor - Short circuit to battery
637	3	Crankshaft position sensor - Short circuit to battery or open circuit
637	4	Crankshaft position sensor - Short circuit to ground
637	31	Crankshaft position sensor - Supply voltage out of range
639	5	Engine Control Unit CAN 1 - Open circuit
639	11	Engine Control Unit CAN 1 - Short circuit
651	0	Injector 1 - Current Rise time too long
651	8	Injector 1 - No current rise time measured
651	5	Injector 1 - Open circuit
651	3	Injector 1 - Short circuit to battery
651	4	Injector 1 - Short circuit to ground
652	0	Injector 19 - Current Rise time too long
652	8	Injector 19 - No current rise time measured
652	5	Injector 19 - Open circuit
652	3	Injector 19 - Short circuit to battery
652	4	Injector 19 - Short circuit to ground
652	0	Injector 2 - Current Rise time too long
652	8	Injector 2 - No current rise time measured
652	5	Injector 2 - Open circuit
652	3	Injector 2 - Short circuit to battery
652	4	Injector 2 - Short circuit to ground
653	0	Injector 3 - Current Rise time too long
653	8	Injector 3 - No current rise time measured
653	5	Injector 3 - Open circuit
653	3	Injector 3 - Short circuit to battery
653	4	Injector 3 - Short circuit to ground
654	0	Injector 4 - Current Rise time too long
654	8	Injector 4 - No current rise time measured
654	5	Injector 4 - Open circuit
654	3	Injector 4 - Short circuit to battery

Standard torques

Error code

SPN	FMI	Designation
654	4	Injector 4 - Short circuit to ground
655	0	Injector 5 - Current Rise time too long
655	8	Injector 5 - No current rise time measured
655	5	Injector 5 - Open circuit
655	3	Injector 5 - Short circuit to battery
655	4	Injector 5 - Short circuit to ground
656	0	Injector 6 - Current Rise time too long
656	8	Injector 6 - No current rise time measured
656	5	Injector 6 - Open circuit
656	3	Injector 6 - Short circuit to battery
656	4	Injector 6 - Short circuit to ground
657	0	Injector 7 - Current Rise time too long
657	8	Injector 7 - No current rise time measured
657	5	Injector 7 - Open circuit
657	3	Injector 7 - Short circuit to battery
657	4	Injector 7 - Short circuit to ground
658	0	Injector 8 - Current Rise time too long
658	8	Injector 8 - No current rise time measured
658	5	Injector 8 - Open circuit
658	3	Injector 8 - Short circuit to battery
658	4	Injector 8 - Short circuit to ground
659	0	Injector 9 - Current Rise time too long
659	8	Injector 9 - No current rise time measured
659	5	Injector 9 - Open circuit
659	5	Injector 9 - Open circuit
659	3	Injector 9 - Short circuit to battery
659	4	Injector 9 - Short circuit to ground
660	0	Injector 10 - Current Rise time too long
660	8	Injector 10 - No current rise time measured
660	5	Injector 10 - Open circuit
660	3	Injector 10 - Short circuit to battery
660	4	Injector 10 - Short circuit to ground
661	0	Injector 11 - Current Rise time too long
661	8	Injector 11 - No current rise time measured
661	5	Injector 11 - Open circuit
661	3	Injector 11 - Short circuit to battery
661	4	Injector 11 - Short circuit to ground
662	0	Injector 12 - Current Rise time too long

SPN	FMI	Designation
662	8	Injector 12 - No current rise time measured
662	5	Injector 12 - Open circuit
662	3	Injector 12 - Short circuit to battery
662	4	Injector 12 - Short circuit to ground
663	0	Injector 13 - Current Rise time too long
663	8	Injector 13 - No current rise time measured
663	5	Injector 13 - Open circuit
663	3	Injector 13 - Short circuit to battery
663	4	Injector 13 - Short circuit to ground
664	0	Injector 14 - Current Rise time too long
664	8	Injector 14 - No current rise time measured
664	5	Injector 14 - Open circuit
664	3	Injector 14 - Short circuit to battery
664	4	Injector 14 - Short circuit to ground
665	0	Injector 15 - Current Rise time too long
665	8	Injector 15 - No current rise time measured
665	5	Injector 15 - Open circuit
665	3	Injector 15 - Short circuit to battery
665	4	Injector 15 - Short circuit to ground
666	0	Injector 16 - Current Rise time too long
666	8	Injector 16 - No current rise time measured
666	5	Injector 16 - Open circuit
666	3	Injector 16 - Short circuit to battery
666	4	Injector 16 - Short circuit to ground
667	0	Injector 17 - Current Rise time too long
667	8	Injector 17 - No current rise time measured
667	5	Injector 17 - Open circuit
667	3	Injector 17 - Short circuit to battery
667	4	Injector 17 - Short circuit to ground
668	0	Injector 18 - Current Rise time too long
668	8	Injector 18 - No current rise time measured
668	5	Injector 18 - Open circuit
668	3	Injector 18 - Short circuit to battery
668	4	Injector 18 - Short circuit to ground
669	8	Injector 18 - No current rise time measured
669	5	Injector 18 - Open circuit
669	3	Injector 18 - Short circuit to battery
669	4	Injector 18 - Short circuit to ground

Standard torques

Error code

SPN	FMI	Designation
669	0	Injector 19 - Current Rise time too long
669	8	Injector 19 - No current rise time measured
669	5	Injector 19 - Open circuit
669	3	Injector 19 - Short circuit to battery
669	4	Injector 19 - Short circuit to ground
670	0	Injector 20 - Current Rise time too long
670	8	Injector 20 - No current rise time measured
670	5	Injector 20 - Open circuit
670	3	Injector 20 - Short circuit to battery
670	4	Injector 20 - Short circuit to ground
677	6	Starter - Critical high output current
677	11	Starter - Electrical error
677	31	Starter - Locked due to overtemperature
677	5	Starter - Open circuit
677	3	Starter - Short circuit to battery
677	3	Starter - Short circuit to battery (high side)
677	3	Starter - Short circuit to battery (low side)
677	3	Starter - Short circuit to battery high side
677	4	Starter - Short circuit to ground
677	4	Starter - Short circuit to ground (high side)
677	4	Starter - Short circuit to ground (low side)
677	4	Starter - Short circuit to ground high side
729	6	Heating flange 1 - Critical high output current
729	11	Heating flange 1 - Electrical error
729	5	Heating flange 1 - Open circuit
729	3	Heating flange 1 - Short circuit to battery
729	3	Heating flange 1 - Short circuit to battery (high side)
729	3	Heating flange 1 - Short circuit to battery (low side)
729	3	Heating flange 1 - Short circuit to battery high side
729	4	Heating flange 1 - Short circuit to ground
729	4	Heating flange 1 - Short circuit to ground (high side)
729	4	Heating flange 1 - Short circuit to ground (low side)
729	4	Heating flange 1 - Short circuit to ground high side
730	6	Heating flange 2 - Critical high output current
730	11	Heating flange 2 - Electrical error
730	5	Heating flange 2 - Open circuit
730	3	Heating flange 2 - Short circuit to battery
730	3	Heating flange 2 - Short circuit to battery (high side)

SPN	FMI	Designation
730	3	Heating flange 2 - Short circuit to battery (low side)
730	3	Heating flange 2 - Short circuit to battery high side
730	4	Heating flange 2 - Short circuit to ground
730	4	Heating flange 2 - Short circuit to ground (high side)
730	4	Heating flange 2 - Short circuit to ground (low side)
730	4	Heating flange 2 - Short circuit to ground high side
966	31	Customer Test Mode - Activated
1075	2	Common rail - Plausibility error
1076	6	Volume control valve - Critical high output current
1076	0	Volume control valve - Critical overcurrent
1076	1	Volume control valve - Critical undercurrent
1076	11	Volume control valve - Load is short circuited
1076	5	Volume control valve - Open circuit
1076	11	Volume control valve - Short circuit load
1076	3	Volume control valve - Short circuit to battery (high side)
1076	3	Volume control valve - Short circuit to battery high side
1076	4	Volume control valve - Short circuit to ground (high side)
1076	4	Volume control valve - Short circuit to ground high side
1136	0	ECU - Critical overtemperature
1136	15	ECU - Overtemperature warning
1136	31	ECU temperature sensor 1 - Supply voltage out of range
1137	9	Cylinder head temperature sensor 1 - Communication error
1137	0	Cylinder head temperature sensor 1 - Critical overtemperature
1137	12	Cylinder head temperature sensor 1 - Internal error
1137	14	Cylinder head temperature sensor 1 - Internal temperature error
1137	5	Cylinder head temperature sensor 1 - Open circuit
1137	15	Cylinder head temperature sensor 1 - Overtemperature warning
1137	11	Cylinder head temperature sensor 1 - Value out of range
1138	9	Cylinder head temperature sensor 2 - Communication error
1138	0	Cylinder head temperature sensor 2 - Critical overtemperature
1138	12	Cylinder head temperature sensor 2 - Internal error
1138	14	Cylinder head temperature sensor 2 - Internal temperature error
1138	5	Cylinder head temperature sensor 2 - Open circuit
1138	15	Cylinder head temperature sensor 2 - Overtemperature warning
1138	11	Cylinder head temperature sensor 2 - Value out of range
1139	9	Cylinder head temperature sensor 3 - Communication error
1139	0	Cylinder head temperature sensor 3 - Critical overtemperature

Standard torques

Error code

SPN	FMI	Designation
1139	12	Cylinder head temperature sensor 3 - Internal error
1139	14	Cylinder head temperature sensor 3 - Internal temperature error
1139	5	Cylinder head temperature sensor 3 - Open circuit
1139	15	Cylinder head temperature sensor 3 - Overtemperature warning
1139	11	Cylinder head temperature sensor 3 - Value out of range
1140	9	Cylinder head temperature sensor 4 - Communication error
1140	0	Cylinder head temperature sensor 4 - Critical overtemperature
1140	12	Cylinder head temperature sensor 4 - Internal error
1140	14	Cylinder head temperature sensor 4 - Internal temperature error
1140	5	Cylinder head temperature sensor 4 - Open circuit
1140	15	Cylinder head temperature sensor 4 - Overtemperature warning
1140	11	Cylinder head temperature sensor 4 - Value out of range
1141	9	Cylinder head temperature sensor 5 - Communication error
1141	0	Cylinder head temperature sensor 5 - Critical overtemperature
1141	12	Cylinder head temperature sensor 5 - Internal error
1141	14	Cylinder head temperature sensor 5 - Internal temperature error
1141	5	Cylinder head temperature sensor 5 - Open circuit
1141	15	Cylinder head temperature sensor 5 - Overtemperature warning
1141	11	Cylinder head temperature sensor 5 - Value out of range
1142	9	Cylinder head temperature sensor 6 - Communication error
1142	0	Cylinder head temperature sensor 6 - Critical overtemperature
1142	12	Cylinder head temperature sensor 6 - Internal error
1142	14	Cylinder head temperature sensor 6 - Internal temperature error
1142	5	Cylinder head temperature sensor 6 - Open circuit
1142	15	Cylinder head temperature sensor 6 - Overtemperature warning
1142	11	Cylinder head temperature sensor 6 - Value out of range
1143	9	Cylinder head temperature sensor 7 - Communication error
1143	0	Cylinder head temperature sensor 7 - Critical overtemperature
1143	12	Cylinder head temperature sensor 7 - Internal error
1143	14	Cylinder head temperature sensor 7 - Internal temperature error
1143	5	Cylinder head temperature sensor 7 - Open circuit
1143	15	Cylinder head temperature sensor 7 - Overtemperature warning
1143	11	Cylinder head temperature sensor 7 - Value out of range
1144	9	Cylinder head temperature sensor 8 - Communication error
1144	0	Cylinder head temperature sensor 8 - Critical overtemperature

SPN	FMI	Designation
1144	12	Cylinder head temperature sensor 8 - Internal error
1144	14	Cylinder head temperature sensor 8 - Internal temperature error
1144	5	Cylinder head temperature sensor 8 - Open circuit
1144	15	Cylinder head temperature sensor 8 - Overtemperature warning
1144	11	Cylinder head temperature sensor 8 - Value out of range
1145	9	Cylinder head temperature sensor 9 - Communication error
1145	0	Cylinder head temperature sensor 9 - Critical overtemperature
1145	12	Cylinder head temperature sensor 9 - Internal error
1145	14	Cylinder head temperature sensor 9 - Internal temperature error
1145	5	Cylinder head temperature sensor 9 - Open circuit
1145	15	Cylinder head temperature sensor 9 - Overtemperature warning
1145	11	Cylinder head temperature sensor 9 - Value out of range
1146	9	Cylinder head temperature sensor 10 - Communication error
1146	0	Cylinder head temperature sensor 10 - Critical overtemperature
1146	12	Cylinder head temperature sensor 10 - Internal error
1146	14	Cylinder head temperature sensor 10 - Internal temperature error
1146	5	Cylinder head temperature sensor 10 - Open circuit
1146	15	Cylinder head temperature sensor 10 - Overtemperature warning
1146	11	Cylinder head temperature sensor 10 - Value out of range
1147	9	Cylinder head temperature sensor 11 - Communication error
1147	0	Cylinder head temperature sensor 11 - Critical overtemperature
1147	12	Cylinder head temperature sensor 11 - Internal error
1147	14	Cylinder head temperature sensor 11 - Internal temperature error
1147	5	Cylinder head temperature sensor 11 - Open circuit
1147	15	Cylinder head temperature sensor 11 - Overtemperature warning
1147	11	Cylinder head temperature sensor 11 - Value out of range
1148	9	Cylinder head temperature sensor 12 - Communication error
1148	0	Cylinder head temperature sensor 12 - Critical overtemperature
1148	12	Cylinder head temperature sensor 12 - Internal error
1148	14	Cylinder head temperature sensor 12 - Internal temperature error
1148	5	Cylinder head temperature sensor 12 - Open circuit
1148	15	Cylinder head temperature sensor 12 - Overtemperature warning

Standard torques

Error code

SPN	FMI	Designation
1148	11	Cylinder head temperature sensor 12 - Value out of range
1149	9	Cylinder head temperature sensor 13 - Communication error
1149	0	Cylinder head temperature sensor 13 - Critical overtemperature
1149	12	Cylinder head temperature sensor 13 - Internal error
1149	14	Cylinder head temperature sensor 13 - Internal temperature error
1149	5	Cylinder head temperature sensor 13 - Open circuit
1149	15	Cylinder head temperature sensor 13 - Overtemperature warning
1149	11	Cylinder head temperature sensor 13 - Value out of range
1150	9	Cylinder head temperature sensor 14 - Communication error
1150	0	Cylinder head temperature sensor 14 - Critical overtemperature
1150	12	Cylinder head temperature sensor 14 - Internal error
1150	14	Cylinder head temperature sensor 14 - Internal temperature error
1150	5	Cylinder head temperature sensor 14 - Open circuit
1150	15	Cylinder head temperature sensor 14 - Overtemperature warning
1150	11	Cylinder head temperature sensor 14 - Value out of range
1151	9	Cylinder head temperature sensor 15 - Communication error
1151	0	Cylinder head temperature sensor 15 - Critical overtemperature
1151	12	Cylinder head temperature sensor 15 - Internal error
1151	14	Cylinder head temperature sensor 15 - Internal temperature error
1151	5	Cylinder head temperature sensor 15 - Open circuit
1151	15	Cylinder head temperature sensor 15 - Overtemperature warning
1151	11	Cylinder head temperature sensor 15 - Value out of range
1152	9	Cylinder head temperature sensor 16 - Communication error
1152	0	Cylinder head temperature sensor 16 - Critical overtemperature
1152	12	Cylinder head temperature sensor 16 - Internal error
1152	14	Cylinder head temperature sensor 16 - Internal temperature error
1152	5	Cylinder head temperature sensor 16 - Open circuit
1152	15	Cylinder head temperature sensor 16 - Overtemperature warning
1152	11	Cylinder head temperature sensor 16 - Value out of range
1153	9	Cylinder head temperature sensor 17 - Communication error
1153	0	Cylinder head temperature sensor 17 - Critical overtemperature
1153	12	Cylinder head temperature sensor 17 - Internal error

SPN	FMI	Designation
1153	14	Cylinder head temperature sensor 17 - Internal temperature error
1153	5	Cylinder head temperature sensor 17 - Open circuit
1153	15	Cylinder head temperature sensor 17 - Overtemperature warning
1153	11	Cylinder head temperature sensor 17 - Value out of range
1154	9	Cylinder head temperature sensor 18 - Communication error
1154	0	Cylinder head temperature sensor 18 - Critical overtemperature
1154	12	Cylinder head temperature sensor 18 - Internal error
1154	14	Cylinder head temperature sensor 18 - Internal temperature error
1154	5	Cylinder head temperature sensor 18 - Open circuit
1154	15	Cylinder head temperature sensor 18 - Overtemperature warning
1154	11	Cylinder head temperature sensor 18 - Value out of range
1155	9	Cylinder head temperature sensor 19 - Communication error
1155	0	Cylinder head temperature sensor 19 - Critical overtemperature
1155	12	Cylinder head temperature sensor 19 - Internal error
1155	14	Cylinder head temperature sensor 19 - Internal temperature error
1155	5	Cylinder head temperature sensor 19 - Open circuit
1155	15	Cylinder head temperature sensor 19 - Overtemperature warning
1155	11	Cylinder head temperature sensor 19 - Value out of range
1156	9	Cylinder head temperature sensor 20 - Communication error
1156	0	Cylinder head temperature sensor 20 - Critical overtemperature
1156	12	Cylinder head temperature sensor 20 - Internal error
1156	14	Cylinder head temperature sensor 20 - Internal temperature error
1156	5	Cylinder head temperature sensor 20 - Open circuit
1156	15	Cylinder head temperature sensor 20 - Overtemperature warning
1156	11	Cylinder head temperature sensor 20 - Value out of range
1172	5	Intake air temperature sensor - Open circuit
1172	3	Intake air temperature sensor - Short circuit to battery
1172	4	Intake air temperature sensor - Short circuit to ground
1172	31	Intake air temperature sensor - Supply voltage out of range
1176	1	Boost pressure - Pressure too high
1176	0	Boost pressure - Pressure too low

Standard torques

Error code

SPN	FMI	Designation
1180	2	Exhaust boost temperature (CMR sensor) - Communication error
1180	2	Exhaust boost temperature 1 (CMR sensor) - Communication error
1180	0	Exhaust temperature before turbocharger 1 - Critical overtemperature
1180	15	Exhaust temperature before turbocharger 1 - Overtemperature warning
1180	2	Turbine inlet temperature sensor 1 - Communication error
1180	12	Turbine inlet temperature sensor 1 - Internal error
1180	14	Turbine inlet temperature sensor 1 - Internal temperature error
1180	5	Turbine inlet temperature sensor 1 - Open circuit
1180	11	Turbine inlet temperature sensor 1 - Value out of range
1181	2	Exhaust boost temperature 2 (CMR sensor) - Communication error
1181	0	Exhaust temperature before turbocharger 2 - Critical overtemperature
1181	15	Exhaust temperature before turbocharger 2 - Overtemperature warning
1181	2	Turbine inlet temperature sensor 2 - Communication error
1181	12	Turbine inlet temperature sensor 2 - Internal error
1181	14	Turbine inlet temperature sensor 2 - Internal temperature error
1181	5	Turbine inlet temperature sensor 2 - Open circuit
1181	11	Turbine inlet temperature sensor 2 - Value out of range
1212	0	Coolant temperature at intercooler - Critical overtemperature
1212	15	Coolant temperature at intercooler - Overtemperature warning
1212	5	Intercooler coolant temperature sensor - Open circuit
1212	3	Intercooler coolant temperature sensor - Short circuit to battery
1212	4	Intercooler coolant temperature sensor - Short circuit to ground
1212	31	Intercooler coolant temperature sensor - Supply voltage out of range
1231	5	Engine Control Unit CAN 2 - Open circuit
1231	11	Engine Control Unit CAN 2 - Short circuit
1239	2	Common rail - Leakage
1239	2	Common rail 1 - Leakage
1239	0	Common rail leakage 1 - Fuel leak
1239	11	Common rail leakage 1 - Out of range
1239	31	Common rail leakage 1 - Supply voltage out of range
1239	0	Common rail leakage sensor 1 - Fuel leak

SPN	FMI	Designation
1239	31	Common rail leakage sensor 1 - Supply voltage out of range
1239	11	Common rail leakage sensor 1 - Value out of range
1240	2	Common rail 2 - Leakage
1240	0	Common rail leakage 2 - Fuel leak
1240	11	Common rail leakage 2 - Out of range
1240	31	Common rail leakage 2 - Supply voltage out of range
1240	0	Common rail leakage sensor 2 - Fuel leak
1240	31	Common rail leakage sensor 2 - Supply voltage out of range
1240	11	Common rail leakage sensor 2 - Value out of range
1349	0	Common rail 2 - Critical overpressure
1349	15	Common rail 2 - Overpressure warning
1349	3	Common rail pressure sensor 2 - Short circuit to battery or open circuit
1349	4	Common rail pressure sensor 2 - Short circuit to ground
1349	31	Common rail pressure sensor 2 - Supply voltage out of range
1636	0	Intake manifold - Critical overtemperature
1636	15	Intake manifold - Overtemperature warning
1636	5	Intake manifold temperature sensor - Open circuit
1636	3	Intake manifold temperature sensor - Short circuit to battery
1636	4	Intake manifold temperature sensor - Short circuit to ground
1636	31	Intake manifold temperature sensor - Supply voltage out of range
1668	5	Engine Control Unit CAN 4 - Open circuit
1668	11	Engine Control Unit CAN 4 - Short circuit
1675	11	Inducement system - Engine restart inhibited (empty DEF tank)
1761	17	DEF tank - Level low
1761	3	DEF tank (level sensor) - Open circuit
1761	4	DEF tank (level sensor) - Short circuit
1761	1	DEF tank (level sensor) - Value out of minimum range
1761	2	DEF tank module - Communication error
2430	11	Coolant level sensor - Out of range
2430	3	Coolant level sensor - Short circuit to battery
2430	4	Coolant level sensor - Short circuit to ground or open circuit
2430	31	Coolant level sensor - Supply voltage out of range
3031	15	DEF tank - Overtemperature warning
3031	3	DEF tank (temperature sensor) - Open circuit
3031	4	DEF tank (temperature sensor) - Short circuit
3031	0	DEF tank (temperature sensor) - Value out of maximum range

Standard torques

Error code

SPN	FMI	Designation
3031	1	DEF tank (temperature sensor) - Value out of minimum range
3222	7	NOx sensor (upstream SCR) - Heater performance error
3224	2	NOx sensor (upstream SCR) - Communication error
3224	31	NOx sensor (upstream SCR) - Installation error
3224	0	NOx sensor (upstream SCR) - Offset error
3224	5	NOx sensor (upstream SCR) - Open circuit
3224	3	NOx sensor (upstream SCR) - Short circuit
3225	2	NOx sensor (upstream SCR) - Sensor removed from exhaust line
3232	7	NOx sensor (downstream SCR) - Heater performance error
3234	2	NOx sensor (downstream SCR) - Communication error
3234	0	NOx sensor (downstream SCR) - Offset error
3234	5	NOx sensor (downstream SCR) - Open circuit
3234	3	NOx sensor (downstream SCR) - Short circuit
3234	31	NOx sensor (downstream SCR) 1 - Installation error
3235	2	NOx sensor (downstream SCR) - Sensor removed from exhaust line
3245	0	Exhaust temperature before turbocharger 1 - Critical over-temperature
3273	5	NOx sensor (downstream SCR) - Open circuit
3273	3	NOx sensor (downstream SCR) - Short circuit
3273	2	NOx sensor (downstream SCR) 2 - Communication error
3273	7	NOx sensor (downstream SCR) 2 - Heater performance error
3273	11	NOx sensor (downstream SCR) 2 - Invalid sensor status
3273	0	NOx sensor (downstream SCR) 2 - Offset error
3273	31	NOx sensor (downstream SCR) 2 - Sensor removed from exhaust line
3279	0	Exhaust temperature before turbocharger 2 - Critical over-temperature
3364	11	DEF tank (quality sensor) - Optical error
3364	0	DEF tank (quality sensor) - Value out of maximum range
3364	1	DEF tank (quality sensor) - Value out of minimum range
3470	2	Turbocharger compressor bypass - Control deviation error
3515	3	DEF tank (temperature sensor at suction position) - Open circuit
3515	15	DEF tank (temperature sensor at suction position) - Overtemperature warning
3515	4	DEF tank (temperature sensor at suction position) - Short circuit

SPN	FMI	Designation
3515	0	DEF tank (temperature sensor at suction position) - Value out of maximum range
3515	1	DEF tank (temperature sensor at suction position) - Value out of minimum range
3516	17	DEF tank - Poor DEF quality
3597	1	Power supply - Critical undervoltage
3597	15	Power supply - Overvoltage warning
3597	17	Power supply - Undervoltage warning
3675	2	Turbocharger compressor bypass - Invalid reference position
3675	31	Turbocharger compressor bypass - Position sensor error
3676	3	Coolant level sensor 2 - Short circuit to battery
3676	4	Coolant level sensor 2 - Short circuit to ground or open circuit
3676	31	Coolant level sensor 2 - Supply voltage out of range
3676	11	Coolant level sensor 2 - Value out of range
3676	1	Engine coolant 2 - Level low
3938	2	Speed adjustment - Plausibility error
3938	3	Speed adjustment (current) - Short circuit to battery
3938	4	Speed adjustment (current) - Short circuit to ground or open circuit
3938	31	Speed adjustment (current) - Supply voltage out of range
3938	3	Speed adjustment (voltage) - Short circuit to battery
3938	30	Speed adjustment (voltage) - Short circuit to ground or open circuit
3938	4	Speed adjustment (voltage) - Short circuit to ground or open circuit
3938	31	Speed adjustment (voltage) - Supply voltage out of range
4076	14	Engine coolant 2 - Level low
4090	15	Engine - High NOx emission
4210	3	Prelubrication pump - Short circuit to battery
4210	4	Prelubrication pump - Short circuit to ground
4340	6	DEF line heater 1 - Critical high output current
4340	11	DEF line heater 1 - Electrical error
4340	5	DEF line heater 1 - Open circuit
4340	3	DEF line heater 1 - Short circuit to battery
4340	4	DEF line heater 1 - Short circuit to ground
4342	6	DEF line heater 2 - Critical high output current
4342	11	DEF line heater 2 - Electrical error
4342	5	DEF line heater 2 - Open circuit
4342	3	DEF line heater 2 - Short circuit to battery

Standard torques

Error code

SPN	FMI	Designation
4342	4	DEF line heater 2 - Short circuit to ground
4360	15	Exhaust gas temperature (upstream SCR) - Overtemperature warning
4360	5	Exhaust gas temperature sensor (upstream SCR) - Open circuit
4360	2	Exhaust gas temperature sensor (upstream SCR) - Plausibility error
4360	3	Exhaust gas temperature sensor (upstream SCR) - Short circuit to battery
4360	4	Exhaust gas temperature sensor (upstream SCR) - Short circuit to ground
4360	31	Exhaust gas temperature sensor (upstream SCR) - Supply voltage out of range
4364	1	SCR system - Very low conversion efficiency
4377	31	NH3 sensor 1 - Installation error
4380	11	NH3 sensor - Electrical error
4383	2	NH3 sensor - Heater performance error
4413	15	Exhaust gas temperature (upstream SCR) 2 - Overtemperature warning
4413	5	Exhaust gas temperature sensor (upstream SCR) 2 - Open circuit
4413	3	Exhaust gas temperature sensor (upstream SCR) 2 - Short circuit to battery
4413	4	Exhaust gas temperature sensor (upstream SCR) 2 - Short circuit to ground
4413	31	Exhaust gas temperature sensor (upstream SCR) 2 - Supply voltage out of range
4413	11	Exhaust gas temperature sensor (upstream SCR) 2 - Plausibility error
4419	1	SCR system 2 - Very low conversion efficiency
4443	31	NH3 sensor 2 - Installation error
4446	11	NH3 sensor 2 - Electrical error
4449	2	NH3 sensor 2 - Heater performance error
4811	0	Piston cooling pressure 1 - Critical overpressure
4811	1	Piston cooling pressure 1 - Critical underpressure
4811	15	Piston cooling pressure 1 - Overpressure warning
4811	17	Piston cooling pressure 1 - Underpressure warning
4811	3	Piston cooling pressure sensor 1 - Short circuit to battery
4811	4	Piston cooling pressure sensor 1 - Short circuit to ground or open circuit
4811	31	Piston cooling pressure sensor 1 - Supply voltage out of range
5368	0	Turbocharger compressor bypass - Overtemperature warning

SPN	FMI	Designation
5386	6	Wastegate valve - Critical high output current
5386	11	Wastegate valve - Electrical error
5386	5	Wastegate valve - Open circuit
5386	3	Wastegate valve - Short circuit to battery (high side)
5386	3	Wastegate valve - Short circuit to battery high side
5386	4	Wastegate valve - Short circuit to ground (high side)
5386	4	Wastegate valve - Short circuit to ground high side
5420	13	Turbocharger compressor bypass - Calibration error
5420	2	Turbocharger compressor bypass - Communication error
5420	31	Turbocharger compressor bypass - Hardware error
5420	11	Turbocharger compressor bypass - No sensor position data available
5449	2	Turbocharger compressor bypass - Communication error detected by control module
5449	31	Turbocharger compressor bypass - Supply voltage out of range
5571	6	Pressure control valve - Critical high output current
5571	0	Pressure control valve - Critical overcurrent
5571	1	Pressure control valve - Critical undercurrent
5571	11	Pressure control valve - Electrical error
5571	5	Pressure control valve - Open circuit
5571	3	Pressure control valve - Short circuit to battery (high side)
5571	3	Pressure control valve - Short circuit to battery high side
5571	4	Pressure control valve - Short circuit to ground (high side)
5571	4	Pressure control valve - Short circuit to ground high side
5745	31	SCR system (DEF injection system) - Defrosting error (AdBlue)
5826	0	Inducement system - Locked in severe power or speed reduction (SCR system failure)
5826	15	Inducement system - Power or speed reduction (SCR system failure)
5826	16	Inducement system - Severe power or speed reduction (SCR system failure)
5826	11	Inducement system - Warning (SCR system failure)
6209	0	Coolant temperature at intercooler - Critical overtemperature
6209	15	Coolant temperature at intercooler - Overtemperature warning
6209	5	Intercooler coolant temperature sensor - Open circuit
6209	3	Intercooler coolant temperature sensor - Short circuit to battery
6209	4	Intercooler coolant temperature sensor - Short circuit to ground

Standard torques

Error code

SPN	FMI	Designation
6209	31	Intercooler coolant temperature sensor - Supply voltage out of range
6301	5	Water in fuel sensor 2 - Open circuit
6301	11	Water in fuel sensor 2 - Out of range
6301	3	Water in fuel sensor 2 - Short circuit to battery
6301	4	Water in fuel sensor 2 - Short circuit to ground
6301	31	Water in fuel sensor 2 - Supply voltage out of range
6301	11	Water in fuel sensor 2 - Value out of range
6301	0	Water in fuel sensor 2 - Water in fuel detected
6303	11	Coolant level sensor 2 - Out of range
6303	3	Coolant level sensor 2 - Short circuit to battery
6303	4	Coolant level sensor 2 - Short circuit to ground or open circuit
6303	31	Coolant level sensor 2 - Supply voltage out of range
6476	31	SCR system - Cooling interruption
6477	31	SCR system - Purge interruption
51644	31	Engine - Starter activated but no engine rotation detected
516101	31	Air filter pressure switch - Supply voltage out of range
516117	11	Common rail - PCV opened due to overpressure
516118	11	Common rail - Plausibility error of VCV current
516121	11	Common rail - Pressure remains above the set point
516122	11	Common rail - Pressure remains below the set point
516123	11	Common rail - Start pressure too low
516124	11	Common rail 2 - PCV opened due to overpressure
516125	11	Common rail 2 - Plausibility error of VCV current
516128	11	Common rail 2 - Pressure remains above the set point
516129	11	Common rail 2 - Pressure remains below the set point
516130	11	Common rail 2 - Start pressure too low
516131	11	Common rail pressure sensor - No signal variation
516133	11	Common rail pressure sensor 2 - No signal variation
516135	6	Machine-specific digital output 1 - Critical high output current
516135	11	Machine-specific digital output 1 - Electrical error
516135	5	Machine-specific digital output 1 - Open circuit
516135	3	Machine-specific digital output 1 - Short circuit to battery
516135	4	Machine-specific digital output 1 - Short circuit to ground
516140	31	ECU temperature sensor 2 - Supply voltage out of range
516141	31	ECU temperature sensor 3 - Supply voltage out of range
516148	5	Engine Control Unit CAN 4 - Open circuit
516148	11	Engine Control Unit CAN 4 - Short circuit

SPN	FMI	Designation
516183	31	Cylinder head temperature sensor - Sensor position assignment error
516187	31	Ignition digital input - Supply voltage out of range
516191	17	Injector supply boost converter - Undervoltage warning
516195	2	Generator Set Controller - Communication error
516197	2	Master Slave Injection - Communication error
516197	2	Secondary injection control unit - Communication error
516198	11	NH3 sensor - Communication error
516199	15	NH3 sensor - High NH3 concentration
516200	11	NH3 sensor - Internal memory error
516201	11	NH3 sensor - Resistance error
516202	11	NH3 sensor - Module-sensor communication error
516203	2	NOx sensor (downstream SCR) - Invalid sensor status
516204	2	NOx sensor (upstream SCR) - Invalid sensor status
516205	11	NOx sensors - Installation error
516209	15	Pressure control valve - Current remains above the set point
516209	17	Pressure control valve - Current remains below the set point
516211	11	Pressure control valve - PWM signal - High limit reached
516212	11	Pressure control valve - PWM signal - Plausibility error
516215	6	Pressure control valve 2 - Critical high output current
516215	0	Pressure control valve 2 - Critical overcurrent
516215	1	Pressure control valve 2 - Critical undercurrent
516215	11	Pressure control valve 2 - Load is short circuited
516215	5	Pressure control valve 2 - Open circuit
516215	11	Pressure control valve 2 - Short circuit load
516215	3	Pressure control valve 2 - Short circuit to battery (high side)
516215	3	Pressure control valve 2 - Short circuit to battery high side
516215	4	Pressure control valve 2 - Short circuit to ground (high side)
516215	4	Pressure control valve 2 - Short circuit to ground high side
516216	11	Pressure control valve 2 - Current remains above the set point
516217	11	Pressure control valve 2 - Current remains below the set point
516220	11	Pressure control valve 2 - PWM signal - High limit reached
516221	11	Pressure control valve 2 - PWM signal - Plausibility error
516223	11	Monitoring System - Ecu internal safety error
516226	11	Monitoring System - Injector safety error
516231	11	SCR system - Defrosting error (DEF)
516233	0	SCR system - Feedback control reached max saturation
516233	1	SCR system - Feedback control reached min saturation

Standard torques

Error code

SPN	FMI	Designation
516247	31	Starter digital input - Supply voltage out of range
516251	0	Volume control valve - Current remains above the set point
516251	11	Volume control valve - Current remains above the set point
516251	1	Volume control valve - Current remains below the set point
516252	11	Volume control valve - Current remains below the set point
516253	0	Volume control valve - PWM signal - High limit reached
516253	11	Volume control valve - PWM signal - High limit reached
516253	8	Volume control valve - PWM signal - Plausibility error
516254	11	Volume control valve - PWM signal - Plausibility error
516255	6	Volume control valve 2 - Critical high output current
516255	0	Volume control valve 2 - Critical overcurrent
516255	1	Volume control valve 2 - Critical undercurrent
516255	11	Volume control valve 2 - Critical undercurrent
516255	31	Volume control valve 2 - Load is short circuited
516255	5	Volume control valve 2 - Open circuit
516255	11	Volume control valve 2 - Short circuit load
516255	3	Volume control valve 2 - Short circuit to battery (high side)
516255	3	Volume control valve 2 - Short circuit to battery high side
516255	4	Volume control valve 2 - Short circuit to ground (high side)
516255	4	Volume control valve 2 - Short circuit to ground high side
516256	0	Volume control valve 2 - Current remains above the set point
516256	11	Volume control valve 2 - Current remains above the set point
516256	1	Volume control valve 2 - Current remains below the set point
516257	11	Volume control valve 2 - Current remains below the set point
516258	0	Volume control valve 2 - PWM signal - High limit reached
516258	11	Volume control valve 2 - PWM signal - High limit reached
516258	31	Volume control valve 2 - PWM signal - Plausibility error
516259	11	Volume control valve 2 - PWM signal - Plausibility error
516264	31	Starter digital input 2 - Supply voltage out of range
516266	3	Wastegate valve - Short circuit to battery (low side)
516266	3	Wastegate valve - Short circuit to battery low side
516266	4	Wastegate valve - Short circuit to ground (low side)
516266	4	Wastegate valve - Short circuit to ground low side
516276	3	Starter - Short circuit to battery low side
516277	4	Starter - Short circuit to ground low side
516281	15	Aftertreatment Protection Power Reduction - Temperature too high
516284	17	Engine protection power reduction - Boost pressure too low

SPN	FMI	Designation
516304	3	Heating flange 1 - Short circuit to battery low side
516305	4	Heating flange 1 - Short circuit to ground low side
516318	31	Wastegate valve - Load is short circuited
516318	31	Wastegate valve - Short circuit load
516328	3	Volume control valve - Short circuit to battery (low side)
516328	3	Volume control valve - Short circuit to battery low side
516328	4	Volume control valve - Short circuit to ground (low side)
516329	4	Volume control valve - Short circuit to ground low side
516330	11	Volume control valve - Electrical error
516331	3	Pressure control valve - Short circuit to battery (low side)
516331	3	Pressure control valve - Short circuit to battery low side
516331	4	Pressure control valve - Short circuit to ground (low side)
516331	4	Pressure control valve - Short circuit to ground low side
516336	11	Volume control valve 2 - Electrical error
516336	3	Volume control valve 2 - Short circuit to battery (low side)
516336	3	Volume control valve 2 - Short circuit to battery low side
516336	4	Volume control valve 2 - Short circuit to ground (low side)
516336	4	Volume control valve 2 - Short circuit to ground low side
516337	11	Pressure control valve 2 - Electrical error
516337	3	Pressure control valve 2 - Short circuit to battery (low side)
516337	3	Pressure control valve 2 - Short circuit to battery low side
516337	4	Pressure control valve 2 - Short circuit to ground (low side)
516337	4	Pressure control valve 2 - Short circuit to ground low side
516340	2	Wastegate valve control module - Communication error
516342	31	Starter - Locked due to overtemperature
516344	3	Heating flange 2 - Short circuit to battery low side
516345	4	Heating flange 2 - Short circuit to ground low side
516346	5	Heating flange status input 1 - Open circuit
516346	3	Heating flange status input 1 - Short circuit to battery
516346	3	Heating flange status input 1 - Short circuit to battery (high side)
516346	3	Heating flange status input 1 - Short circuit to battery (low side)
516346	3	Heating flange status input 1 - Short circuit to battery high side
516346	4	Heating flange status input 1 - Short circuit to ground
516346	4	Heating flange status input 1 - Short circuit to ground (high side)
516346	4	Heating flange status input 1 - Short circuit to ground (low side)

Standard torques

Error code

SPN	FMI	Designation
516346	4	Heating flange status input 1 - Short circuit to ground high side
516347	3	Heating flange status input 1 - Short circuit to battery low side
516347	4	Heating flange status input 1 - Short circuit to ground low side
516348	5	Heating flange status input 2 - Open circuit
516348	8	Heating flange status input 2 - Open circuit
516348	3	Heating flange status input 2 - Short circuit to battery
516348	3	Heating flange status input 2 - Short circuit to battery (high side)
516348	3	Heating flange status input 2 - Short circuit to battery (low side)
516348	3	Heating flange status input 2 - Short circuit to battery high side
516348	4	Heating flange status input 2 - Short circuit to ground
516348	4	Heating flange status input 2 - Short circuit to ground (high side)
516348	4	Heating flange status input 2 - Short circuit to ground (low side)
516348	4	Heating flange status input 2 - Short circuit to ground high side
516349	3	Heating flange status input 2 - Short circuit to battery low side
516349	4	Heating flange status input 2 - Short circuit to ground low side
516355	31	Engine control unit - Communication error with aftertreatment control module
516356	31	Engine control unit - Communication error to secondary injection control module
516356	31	Engine control unit - Communication error to slave injection control unit
516369	6	Starter 2 - Critical high output current
516369	11	Starter 2 - Electrical error
516369	31	Starter 2 - Locked due to overtemperature
516369	5	Starter 2 - Open circuit
516369	3	Starter 2 - Short circuit to battery
516369	3	Starter 2 - Short circuit to battery (high side)
516369	3	Starter 2 - Short circuit to battery (low side)
516369	3	Starter 2 - Short circuit to battery high side
516369	4	Starter 2 - Short circuit to ground
516369	4	Starter 2 - Short circuit to ground (high side)
516369	4	Starter 2 - Short circuit to ground (low side)
516369	4	Starter 2 - Short circuit to ground high side
516370	3	Starter 2 - Short circuit to battery low side
516371	4	Starter 2 - Short circuit to ground low side

SPN	FMI	Designation
516401	31	Injector 1 - Voltage Based Small quantity injection correction failed
516402	31	Injector 2 - Voltage Based Small quantity injection correction failed
516403	31	Injector 3 - Voltage Based Small quantity injection correction failed
516404	31	Injector 4 - Voltage Based Small quantity injection correction failed
516405	31	Injector 5 - Voltage Based Small quantity injection correction failed
516406	31	Injector 6 - Voltage Based Small quantity injection correction failed
516407	31	Injector 7 - Voltage Based Small quantity injection correction failed
516408	31	Injector 8 - Voltage Based Small quantity injection correction failed
516409	31	Injector 9 - Voltage Based Small quantity injection correction failed
516410	31	Injector 10 - Voltage Based Small quantity injection correction failed
516411	31	Injector 11 - Voltage Based Small quantity injection correction failed
516412	31	Injector 12 - Voltage Based Small quantity injection correction failed
516413	31	Injector 13 - Voltage Based Small quantity injection correction failed
516414	31	Injector 14 - Voltage Based Small quantity injection correction failed
516415	31	Injector 15 - Voltage Based Small quantity injection correction failed
516416	31	Injector 16 - Voltage Based Small quantity injection correction failed
516417	31	Injector 17 - Voltage Based Small quantity injection correction failed
516418	31	Injector 18 - Voltage Based Small quantity injection correction failed
516419	31	Injector 19 - Voltage Based Small quantity injection correction failed
516420	31	Injector 20 - Voltage Based Small quantity injection correction failed
516422	11	Pressure control valve - Load is short circuited
516422	11	Pressure control valve - Short circuit load
516424	11	Starter digital input - Starter inhibition due to short circuit
516425	11	Starter digital input 2 - Starter inhibition due to short circuit

Standard torques

Error code

SPN	FMI	Designation
516428	31	Air pressure sensors - Plausibility error
516490	2	Aftertreatment control module - Communication error
516493	31	Secondary injection control unit - Error detected
516493	31	Slave injection control unit - Emission relevant error
516495	31	ECU - Runtime reached the maximum time without reset
516509	31	Injection data synchronization - Error during measurement of voltage-based small quantity injection correction
516511	31	Starters - Not connected in the output 1 to ECU
516511	31	Starters - Not connected in the output 1 to ECU
516512	31	Starters - Not connected in the output 2 to ECU
516513	31	NOx sensors - Drift error
516543	31	ECU - Data recorder was triggered
516543	31	ECU - Data recorder was triggered and locked on critical error (overspeed or crankcase over pressure)
516544	31	Engine - Starter activated but engine not started
516544	31	Engine - Starter activated but no engine rotation detected
516553	0	SCR system - Critical overload of accumulate carbon in catalyst
516553	15	SCR system - Overload warning of accumulate carbon in catalyst
516571	31	SCR system - DEF not defrosted after legal time elapsed
516581	3	SCR system (DEF injector1) - Short circuit to battery
516581	4	SCR system (DEF injector1) - Short circuit to ground
516582	3	SCR system (DEF injector2) - Short circuit to battery
516582	4	SCR system (DEF injector2) - Short circuit to ground
516583	3	SCR system (DEF injector3) - Short circuit to battery
516583	4	SCR system (DEF injector3) - Short circuit to ground
516584	3	SCR system (DEF injector4) - Short circuit to battery
516584	4	SCR system (DEF injector4) - Short circuit to ground
516585	3	SCR system (DEF injector5) - Short circuit to battery
516585	4	SCR system (DEF injector5) - Short circuit to ground
516586	3	SCR system (DEF injector6) - Short circuit to battery
516586	4	SCR system (DEF injector6) - Short circuit to ground
516587	3	SCR system (DEF injector7) - Short circuit to battery
516587	4	SCR system (DEF injector7) - Short circuit to ground
516588	3	SCR system (DEF injector8) - Short circuit to battery
516588	4	SCR system (DEF injector8) - Short circuit to ground
516589	15	SCR system (DEF pump inlet temperature) - Temperature too high

SPN	FMI	Designation
516589	2	SCR system (DEF pump inlet temperature) - Temperature too low (not plausible)
516589	0	SCR system (DEF pump inlet temperature) - Value out of maximum range
516589	1	SCR system (DEF pump inlet temperature) - Value out of minimum range
516590	2	SCR system (DEF pump outlet pressure) - Plausibility error
516590	15	SCR system (DEF pump outlet pressure) - Pressure high
516590	17	SCR system (DEF pump outlet pressure) - Pressure low
516590	16	SCR system (DEF pump outlet pressure) - Pressure too high
516590	0	SCR system (DEF pump outlet pressure) - Value out of maximum range
516590	1	SCR system (DEF pump outlet pressure) - Value out of minimum range
516591	2	SCR system (Common rail urea pressure) - Plausibility error
516591	15	SCR system (Common rail urea pressure) - Pressure high
516591	17	SCR system (Common rail urea pressure) - Pressure low
516591	16	SCR system (Common rail urea pressure) - Pressure too high
516591	0	SCR system (Common rail urea pressure) - Value out of maximum range
516591	1	SCR system (Common rail urea pressure) - Value out of minimum range
516592	3	SCR system (Primary DCU Sensor supply) - Critical overvoltage
516592	4	SCR system (Primary DCU Sensor supply) - Critical undervoltage
516593	3	SCR system (Primary DCU Battery monitor) - Critical overvoltage
516593	4	SCR system (Primary DCU Battery monitor) - Critical undervoltage
516594	9	SCR system (Primary DCU) - Communication error with ECU
516595	9	SCR system (Primary DCU) - Communication error with Secondary DCU 1
516597	2	SCR system (Primary DCU) - Electrical error on CAN1
516598	2	SCR system (Primary DCU) - Electrical error on CAN2
516599	3	SCR system (Secondary 1 DCU Battery monitor) - Critical overvoltage
516599	4	SCR system (Secondary 1 DCU Battery monitor) - Critical undervoltage
516600	3	SCR system (Secondary 1 DCU Sensor supply) - Critical overvoltage
516600	4	SCR system (Secondary 1 DCU Sensor supply) - Critical undervoltage

Standard torques

Error code

SPN	FMI	Designation
516601	3	SCR system (Secondary 2 DCU Battery monitor) - Critical over-voltage
516601	4	SCR system (Secondary 2 DCU Battery monitor) - Critical under-voltage
516602	3	SCR system (Secondary 2 DCU Sensor supply) - Critical over-voltage
516602	4	SCR system (Secondary 2 DCU Sensor supply) - Critical under-voltage
516603	11	NH3 sensor 2 - Communication error
516604	11	NH3 sensor 2 - Resistance error
516605	11	NH3 sensor 2 - Module-sensor communication error
516606	11	NH3 sensor 2 - Internal memory error
516608	15	NH3 sensor 2 - High NH3 concentration
516655	1	SCR system 3 - Very low conversion efficiency
516656	1	SCR system 4 - Very low conversion efficiency
516658	0	SCR system 2 - Feedback control reached max saturation
516658	1	SCR system 2 - Feedback control reached min saturation
516659	0	SCR system 3 - Feedback control reached max saturation
516659	1	SCR system 3 - Feedback control reached min saturation
516660	0	SCR system 4 - Feedback control reached max saturation
516660	1	SCR system 4 - Feedback control reached min saturation
516662	5	NOx sensor (downstream SCR) - Open circuit
516662	3	NOx sensor (downstream SCR) - Short circuit
516662	2	NOx sensor (downstream SCR) 3 - Communication error
516662	7	NOx sensor (downstream SCR) 3 - Heater performance error
516662	11	NOx sensor (downstream SCR) 3 - Invalid sensor status
516662	0	NOx sensor (downstream SCR) 3 - Offset error
516662	31	NOx sensor (downstream SCR) 3 - Sensor removed from exhaust line
516663	5	NOx sensor (downstream SCR) - Open circuit
516663	3	NOx sensor (downstream SCR) - Short circuit
516663	2	NOx sensor (downstream SCR) 4 - Communication error
516663	7	NOx sensor (downstream SCR) 4 - Heater performance error
516663	11	NOx sensor (downstream SCR) 4 - Invalid sensor status
516663	0	NOx sensor (downstream SCR) 4 - Offset error
516663	31	NOx sensor (downstream SCR) 4 - Sensor removed from exhaust line
516666	1	SCR system - DEF level too low for cooling
516667	31	SCR system - Failed to prime

SPN	FMI	Designation
516668	31	Secondary injection control unit - Error of messages configuration received from the ECU
516669	31	Engine control unit - Error of messages configuration received from the secondary injection control module
516679	11	NH3 sensor 3 - Electrical error
516679	15	NH3 sensor 3 - High NH3 concentration
516679	2	NH3 sensor 3 - Communication error
516679	31	NH3 sensor 3 - Installation error
516680	11	NH3 sensor 3 - Heater performance error
516681	11	NH3 sensor 3 - Internal memory error
516682	11	NH3 sensor 3 - Module-sensor communication error
516683	11	NH3 sensor 3 - Resistance error
516684	11	NH3 sensor 4 - Electrical error
516684	15	NH3 sensor 4 - High NH3 concentration
516684	2	NH3 sensor 4 - Communication error
516684	31	NH3 sensor 4 - Installation error
516685	11	NH3 sensor 4 - Heater performance error
516686	11	NH3 sensor 4 - Internal memory error
516687	11	NH3 sensor 4 - Module-sensor communication error
516688	11	NH3 sensor 4 - Resistance error
516689	15	Exhaust gas temperature (upstream SCR) 3 - Overtemperature warning
516689	5	Exhaust gas temperature sensor (upstream SCR) 3 - Open circuit
516689	3	Exhaust gas temperature sensor (upstream SCR) 3 - Short circuit to battery
516689	4	Exhaust gas temperature sensor (upstream SCR) 3 - Short circuit to ground
516689	31	Exhaust gas temperature sensor (upstream SCR) 3 - Supply voltage out of range
516689	11	Exhaust gas temperature sensor (upstream SCR) - 3 Plausibility error
516690	15	Exhaust gas temperature (upstream SCR) 4 - Overtemperature warning
516690	5	Exhaust gas temperature sensor (upstream SCR) 4 - Open circuit
516690	3	Exhaust gas temperature sensor (upstream SCR) 4 - Short circuit to battery
516690	4	Exhaust gas temperature sensor (upstream SCR) 4 - Short circuit to ground
516690	31	Exhaust gas temperature sensor (upstream SCR) 4 - Supply voltage out of range

Standard torques

Error code

SPN	FMI	Designation
516690	11	Exhaust gas temperature sensor (upstream SCR) - 4 Plausibility error
516714	31	Cylinder head temperature 1 - Cold cylinder
516715	31	Cylinder head temperature 2 - Cold cylinder
516716	31	Cylinder head temperature 3 - Cold cylinder
516717	31	Cylinder head temperature 4 - Cold cylinder
516718	31	Cylinder head temperature 5 - Cold cylinder
516719	31	Cylinder head temperature 6 - Cold cylinder
516720	31	Cylinder head temperature 7 - Cold cylinder
516721	31	Cylinder head temperature 8 - Cold cylinder
516722	31	Cylinder head temperature 9 - Cold cylinder
516723	31	Cylinder head temperature 10 - Cold cylinder
516724	31	Cylinder head temperature 11 - Cold cylinder
516725	31	Cylinder head temperature 12 - Cold cylinder
516726	31	Cylinder head temperature 13 - Cold cylinder
516727	31	Cylinder head temperature 14 - Cold cylinder
516728	31	Cylinder head temperature 15 - Cold cylinder
516729	31	Cylinder head temperature 16 - Cold cylinder
516730	31	Cylinder head temperature 17 - Cold cylinder
516731	31	Cylinder head temperature 18 - Cold cylinder
516732	31	Cylinder head temperature 19 - Cold cylinder
516733	31	Cylinder head temperature 20 - Cold cylinder
516742	3	Speed adjustment (current) - Short circuit to battery
516742	30	Speed adjustment (current) - Short circuit to ground or open circuit
516742	31	Speed adjustment (current) - Supply voltage out of range
516748	3	SCR system (pump heater or common rail heater) - Short circuit to battery
516748	4	SCR system (pump heater or common rail heater) - Short circuit to ground
516749	31	SCR system (pump inlet vacuum sensor) - Rationality low
516749	3	SCR system (pump inlet vacuum sensor) - Short circuit to battery
516749	4	SCR system (pump inlet vacuum sensor) - Short circuit to ground
516750	3	SCR system (filter heater) - Short circuit to battery
516750	4	SCR system (filter heater) - Short circuit to ground
516751	3	SCR system (BLDC port) - Short circuit to battery
516752	0	SCR system (filter) - Run time critical

SPN	FMI	Designation
516752	16	SCR system (filter) - Run time warning
516753	18	SCR system (DEF pump) - Cavitation protection capability low
516753	1	SCR system (DEF pump) - Cavitation protection capability too low
516754	2	SCR system - Variant coding procedure failed
516755	2	SCR system - Runtime reset procedure failed
516758	31	Prelubrication pump - Relay out of order
516762	31	SCR system - Dosing deviation error
516763	31	SCR system 2 - Dosing deviation error
516764	31	SCR system 3 - Dosing deviation error
516765	31	SCR system 4 - Dosing deviation error
516795	0	SCR system (DEF injector) - Temperature too high
516798	31	Volume control valve 2 - Current plausibility error
516812	31	Volume control valve - Current plausibility error
516842	31	NOx sensor (downstream SCR) 2 - Installation error
516843	31	NOx sensor (downstream SCR) 3 - Installation error
516844	31	NOx sensor (downstream SCR) 4 - Installation error
516846	6	Smart sensor supply relay 1 - Critical high output current
516846	11	Smart sensor supply relay 1 - Electrical error
516846	5	Smart sensor supply relay 1 - Open circuit
516846	3	Smart sensor supply relay 1 - Short circuit to battery
516846	4	Smart sensor supply relay 1 - Short circuit to ground
516847	6	Smart sensor supply relay 2 - Critical high output current
516847	11	Smart sensor supply relay 2 - Electrical error
516847	5	Smart sensor supply relay 2 - Open circuit
516847	3	Smart sensor supply relay 2 - Short circuit to battery
516847	4	Smart sensor supply relay 2 - Short circuit to ground
516848	6	Smart sensor supply relay 3 - Critical high output current
516848	11	Smart sensor supply relay 3 - Electrical error
516848	5	Smart sensor supply relay 3 - Open circuit
516848	3	Smart sensor supply relay 3 - Short circuit to battery
516848	4	Smart sensor supply relay 3 - Short circuit to ground
516852	31	Production Mode - Enter/exit mode

Tab. 66: Error code table

33521029401_8_1 EN_US 2023-12-11

© 2023 by Kohler Co. All rights reserved.