

安装步骤

如何安装出水口

将固定螺栓(3)拧到水龙头底座(2)。把垫圈(4)套进软管(1)和固定螺栓,并嵌入水龙头底座槽中。

把供水软管插入脸盆中孔,调整水龙头的位置,从脸盆的下方把垫片(5)和垫片(6)套入固定螺栓,锁紧螺母(7)以固定水龙头。

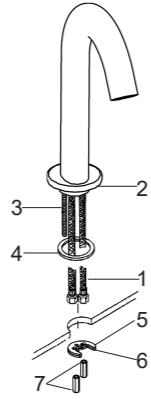

INSTALLATION

How to Install the Spout

Install mounting studs(3) into the faucet body base(2). Slide the washer(4) over the flexible hoses(1) and mounting studs, and into the groove on the bottom of faucet body.

Insert the flexible hoses into the center hole of lavatory. Position the faucet. From underside of the lavatory, fit the washer(5) and washer(6) on the mounting studs, and secure the faucet with the nuts(7).

How to Install the Valve Bodies And the Handles

Put the washer(8) into the groove on the bottom of the escutcheon(9). Insert the valve body(12) with washer(10) and nut(11) through mounting hole from underside of lavatory, and thread it to escutcheon(The valve body with red mark on the left when facing the faucet). Install the handle(13) onto the spline adapter(14).

Adjust the valve bodies. The illustration shown is the correct position of the handles in the valves closed position. Tighten the screw(16) by the hex wrench(15).

Wrench tighten nuts(11). Attach the hoses to valve bodies. Attach the water supplies to the valve bodies. Hot water connects to left valve body, cold water connects to right valve body.

如何安装阀体和把手

将垫片(8)嵌入装饰盖(9)底面凹槽中。将带有垫片(10)和锁紧螺母(11)的阀体组件(12)从脸盆下方穿过安装孔旋到装饰盖上(面对水龙头,贴有红色标记的阀体装在左侧)。将把手(13)装到齿套(14)上。

调整阀体,阀处于关闭位置,使把手的状态如图所示。然后用六角扳手(15)锁紧螺钉(16)。

用扳手拧紧锁紧螺母(11)。把软管接到阀体上。将冷热水源接到阀体,左侧接热水,右侧接冷水。

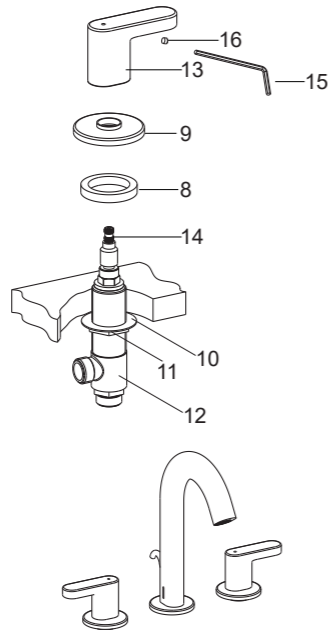

如何安装排水器 仅用于“CP”表面

将止水塞(17)、法兰盘(19)及垫片(20)从排水本体(24)取下,在法兰盘底面套上垫片。尾管(26)从排水本体上取下。在尾管螺纹处须缠绕足以密封的密封胶带或涂合适的密封胶,装回排水本体。把带垫圈(21)、钢垫(22)及锁紧螺母(23)的排水本体由洗脸盆孔下部插入,排水杆洞口(25)朝后方。

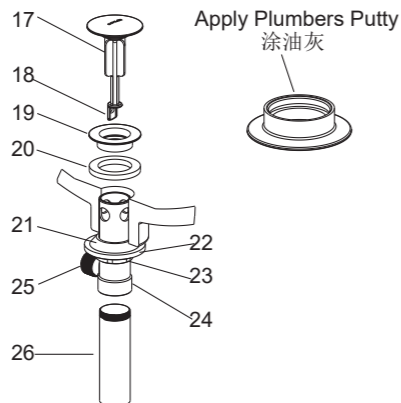

How to Install the Drain Only for 'CP' Finish

Uninstall the stopper(17), drain flange(19) and washer(20) from drain body(24). Slide washer onto the backside of the drain flange. Uninstall the tailpiece(26) from the drain body. Supply enough tape or sealant to tailpiece thread. Reinstall the tailpiece. Insert the drain body with gasket(21), steel washer(22) and locknut(23) into the lavatory from underside, with the drain lever hole(25) facing the rear.

注意:如果需要可直接在法兰盘底面沿周围涂一圈密封油灰,而不用垫片(20)。

把法兰盘旋入排水本体中。从下方用手拧紧锁紧螺母。把止水塞放入排水本体中,调整以使止水塞末端的孔(18)靠近并对正排水杆洞口。

松开接头(30)的螺钉(32),取下接头。将固定螺母(28)取下,把塑料垫片(27)及固定螺母装在球杆(29)上,将球杆组件插入排水杆洞口(25)并穿过止水塞,拧紧固定螺母。

确保球杆指向脸盆后方,并拧紧排水本体上的锁紧螺母。

注意:在锁紧螺母转紧后,不可调整排水本体的位置,否则会破坏油灰密封。去除多余的油灰。

如何安装提拉杆组件 仅用于“CP”表面

将提拉杆组件(31)插入出水口后侧孔。根据所选脸盆尺寸,选择排水器与水龙头提拉杆的连接方式。

方式一:选用接头(30)

接头(30)大孔(33)套到球杆(29)上,将提拉杆下部插入接头小孔中。调整提拉杆的高度,使提拉杆头到台面的高度控制在55~60mm。将球杆下推到排水器全开位置。锁紧接头上的螺钉(32)。

方式二:选用联动组件(34, 35 & 36)

根据尺寸及提拉杆的长度,折弯连杆(35)。用V形夹(36)将连杆连接到球杆组件上,将提拉杆(31)插入到连杆的孔中,调整提拉杆的高度,使提拉杆头到台面的高度控制在55~60mm。将球杆(29)下推到排水器全开位置。拧紧手捻螺丝(34)。

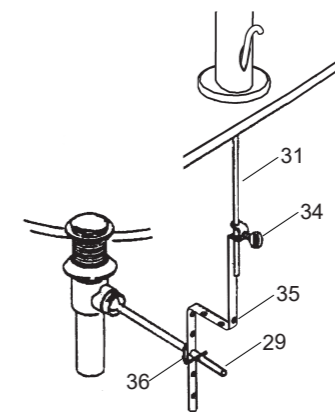
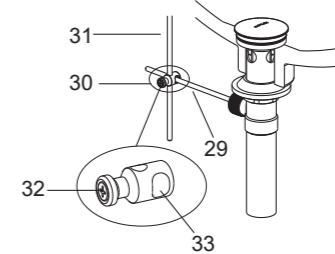
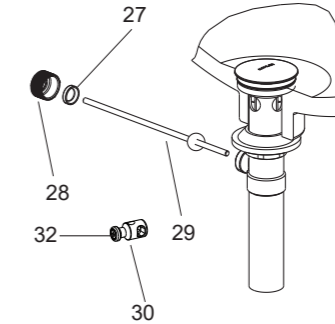

NOTE: If necessary apply a ring of plumbers putty around the underside of the drain flange, instead of using washer(20).

Thread the drain flange onto the drain body. Hand tighten the locknut from the underside of the lavatory. Place stopper into drain body, aligning the flat side of stopper hole(18) with the drain lever hole.

Loosen the screw(32) on the latch(30), take off the latch. Remove the retaining nut(28). Fit the plastic washer(27) and retaining nut onto the ball lever rod(29). Insert the ball lever assembly into the drain lever hole(25) and through the stopper hole. Tighten the retaining nut.

Be sure that the ball lever rod points to the back of the lavatory, tighten the locknut.

NOTE: Do not reposition the drain after the locknut is tightened, or you may break the putty seal. Remove any excess putty.

How to Install the Lift Rod Kit Only for 'CP' Finish

Insert the lift rod assembly(31) into the rear hole of spout. Select connection of the drain and the lift rod according to the dimension of lavatory.

Way 1: Select the latch(30)

Insert the ball lever rod(29) into the bigger hole(33) of the latch(30). Insert the lift rod into the other hole of latch. Position the lift rod, make sure the height between lift rod and table is controlled within the range of 55~60mm. Push the ball lever rod down to the open position. Tighten the screw(32) on the latch.

Way 2: Select the link kit(34, 35 & 36).

According to the lift rod length, bend the link(35). Connect the link onto ball lever rod with 'V'-clip(36). Slide lift rod(31) into the hole on link. Position the lift rod, make sure the height between lift rod and table is controlled within the range of 55~60mm. Push the ball lever rod(29) down to the open position. Tighten thumb screw(34).

打开主要供水源和排水系统，检查并修理有漏水的接口。

用工具(52)拆下起泡器(51)，打开水龙头的冷热水，让水流出约一分钟以清除杂质，检查渗漏。冲洗起泡器，关闭水龙头，重新装回起泡器。

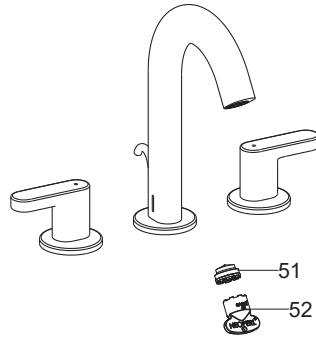

Turn on the main water supply and drain, and check for leaks. Repair as needed.

Remove the aerator(51) by the key(52). Turn the faucet handles on. Run hot and cold water through spout for about one minute to remove any debris. Check for leaks. Repair as needed. Remove any debris from the aerator. Shut off the faucet. Reinstall the aerator.

清洗说明

适用于所有加工处理过的表面：以中性肥皂水清洗镀层表面，再以干净的软布彻底擦干整个表面，许多清洁剂，比如氨水、去污粉及洁厕灵等，会对电镀表面造成伤害，切忌使用。

有磨损性的清洁用具或清洁剂也不可适用于科勒牌的水龙头及其配件上。

CLEANING INSTRUCTIONS

All Finishes: Clean the finish with mild soap and warm water. Wipe entire surface completely dry with clean soft cloth. Many cleaners may contain chemicals, such as ammonia, chlorine, toilet cleaner etc. which could adversely affect the finish and are not recommended for cleaning.

Do not use abrasive cleaners or solvents on Kohler faucets and fittings.

4998T-4 8" 脸盆龙头

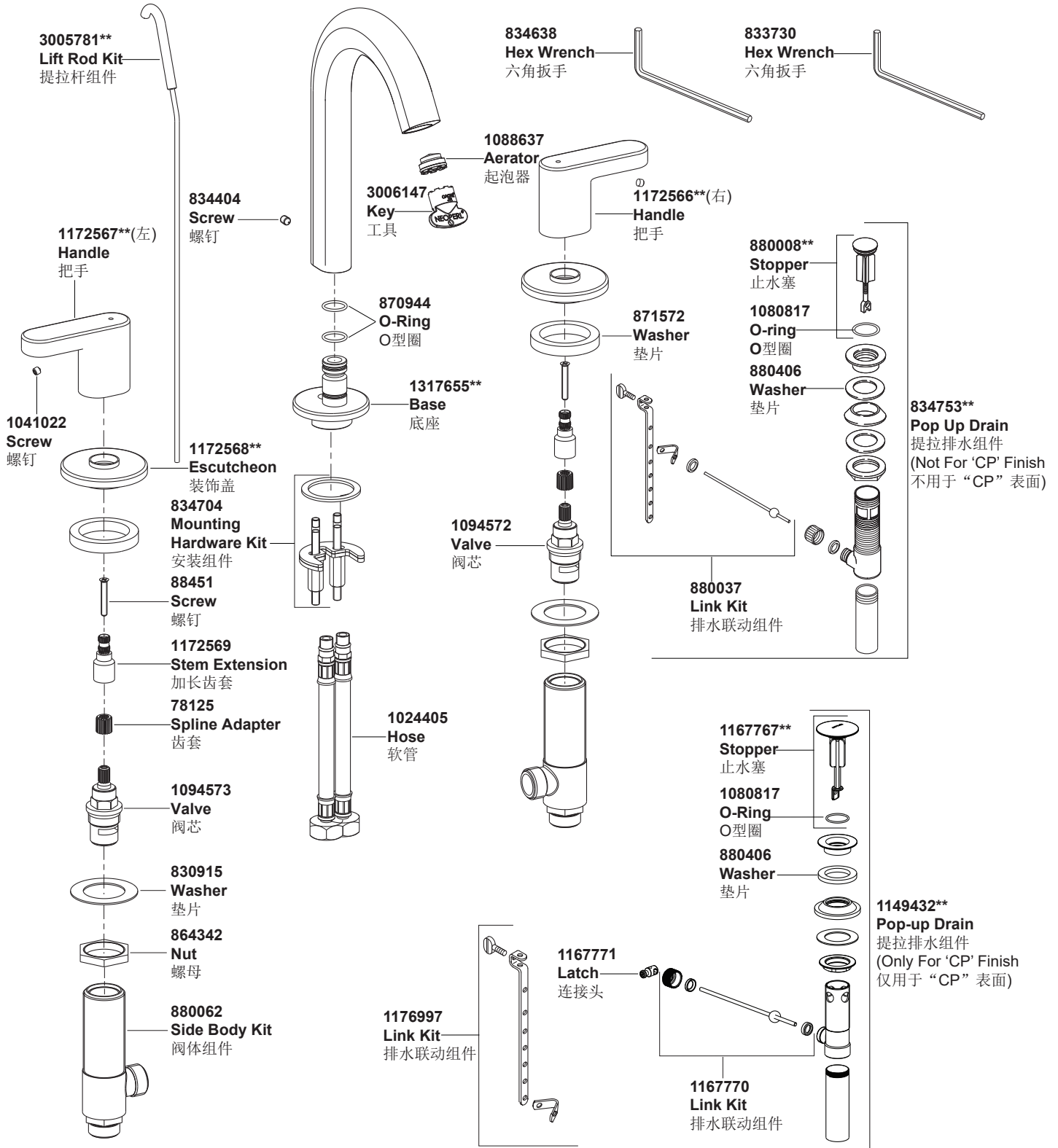

**订购时请说明颜色编号

**Color code must be specified when ordering