

BEFORE YOU BEGIN

安装之前

- All information is based on the latest product information available at the time of publication. Kohler China Ltd. reserves the right to make changes in product characteristics, packaging, or availability at any time without notice.
- These instructions contain important care, cleaning, and warranty information—**please leave these instructions for the consumer.**
- Make sure that the bath and the finished wall material are completely and correctly installed prior to installing your shower door. Prepare waterproof layer to wall and floor of the showering area. It is not allowed for any presence of electric switches and sockets. Make sure the floor drain runs smoothly.
- Before starting the door installation, lay out and identify all the parts. Use the exploded view illustrated on page 2 for reference.
- For the installation method of customized shower with different dimensions, please refer to this instructions.
- The product complies with QB 2584-2007.

⚠ CAUTION: Risk of injury or product damage.
 Tempered glass cannot be cut, drilled or knocked by hard object. Make sure corner area of the glass refraining from knocking so as to cause personal injury due to broken glass.

ATTENTION: Please install this product on Kohler's inner edge of long floor drain(Not included).

IMPORTANT: The shower door requires a flat vertical finished wall. The squareness of the wall is recommended no more than 3 mm/m. KOHLER Company won't take responsibility of the installation quality.

- 说明书中所有的资料是按最新出版的产品资料编写而成。科勒中国有限公司保留任何时候无须通知即可改变产品特性、包装或产品可供类型的权利。
- 说明书包括重要的安装、清洁及保养方面的内容，**请把这些资料交给用户阅读，保管。**
- 确保在安装淋浴房之前已经完整正确地安装了浴室和完工墙面材料。淋浴区墙地面应做防水处理，并不得布置有电器开关、插座。确保地面排水通畅。
- 在进行淋浴房安装之前，请拿出、排列并确认所有的零部件。请参考第 2 页上所示的分解图。
- 对尺寸与本标准产品不同的定制淋浴房，参照本说明书进行安装。
- 本产品符合 QB 2584-2007。

⚠ 警告：可能有人伤害或者产品损坏的危险。
 钢化玻璃不能进行切割，钻孔或硬物敲击。搬移或安装过程中，小心确保玻璃边、角部位不受撞击，以防爆裂伤人。

建议：将本产品安装在科勒长条地漏内沿(需另行购买)。

重要事项：淋浴房需要安装在平坦垂直的墙面上。墙面的垂直度推荐在正负 3mm/m 以内。如果超出此范围，科勒公司将不保证淋浴房的完美使用。

ROUGHING-IN

尺寸图

Do not use the enclosure for at least 24 hours.
 安装后 24 小时内请勿使用淋浴房。

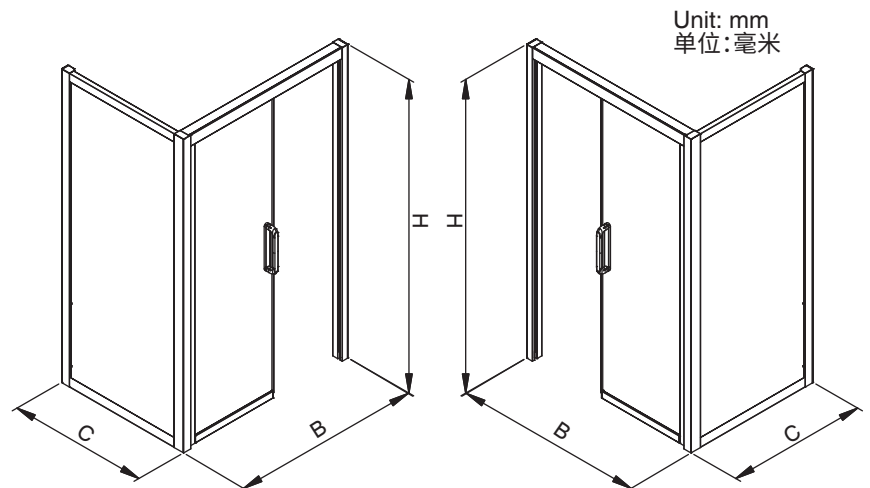

SKU	B	C	H
K-705018T	900-1600	250-1100	2000-2200

ZHONGSHAN KOHLER SHOWER CO., LTD. NO13-1, XINGYE ROAD, ZHONGSHAN TORCH DEVELOPMENT ZONE, ZHONGSHAN, GUANGDONG, CHINA POST CODE: 528437
 中山科勒卫浴有限公司 广东省中山市中山火炬开发区兴业路 13-1 号 邮编:528437

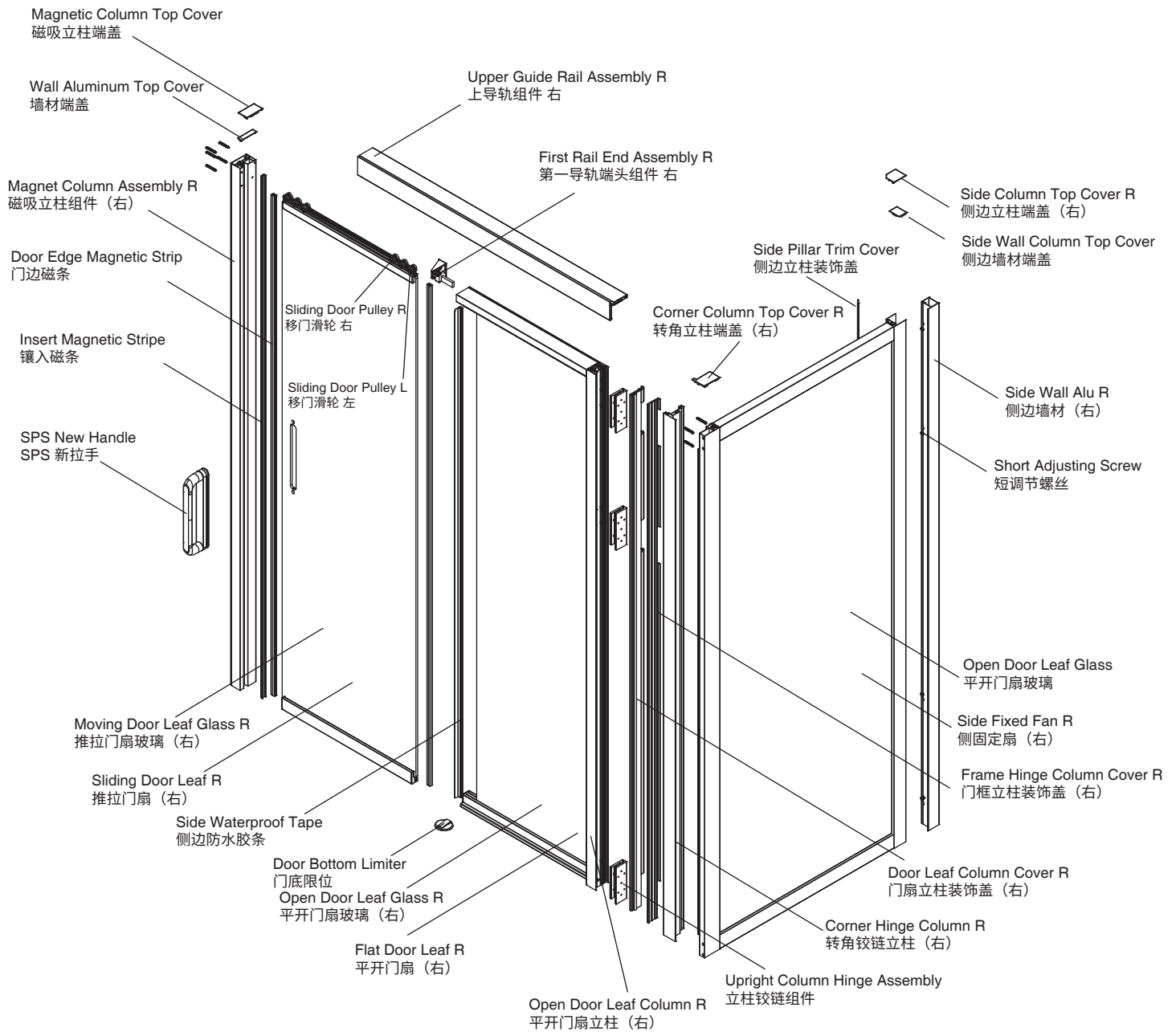

	X1	Magnet Column Assembly 磁吸立柱组件
	X1	Upper Guide Rail Assembly 上导轨组件
	X1	Corner Hinge Column 转角铰链立柱
	X1	Flat Door Leaf 平开门扇
	X1	Sliding Door Leaf 推拉门扇
	X1	Side Fixed Fan 侧固定扇
	X1	Side Pillar Trim Cover 侧边立柱装饰盖

	X1	Frame Hinge Column Cover 门框立柱装饰盖
	X1	First Rail End Assembly 第一导轨端头组件
	X1	SPS New Handle SPS 新拉手
	X1	Door Bottom Limiter 门底限位
	X1	Column Top Cover 铝材端盖
	X14	Screw ST3.5x20 Lock side wall frame 圆头螺丝 锁侧框 ST3.5x20
	X2	Screw ST3.5x30 Lock the ground 沉头螺丝 锁地吸 ST3.5x30
	X9	Screw ST3.5x14 Lock the hinge 沉头螺丝 锁铰链 ST3.5x14
	X14	Hollow Wall Anchor, Nylon 膨胀套
	X14	Pan Screw ST3.5x35 Lock the wall + Lock rail end assembly 圆头螺丝 ST3.5x35 锁墙+导轨端头
	X8	Pan Screw ST3.5x50 圆头螺丝 ST3.5x50
	X1	Screw Key 4mm 加长六角扳手

Tools Required/所需工具

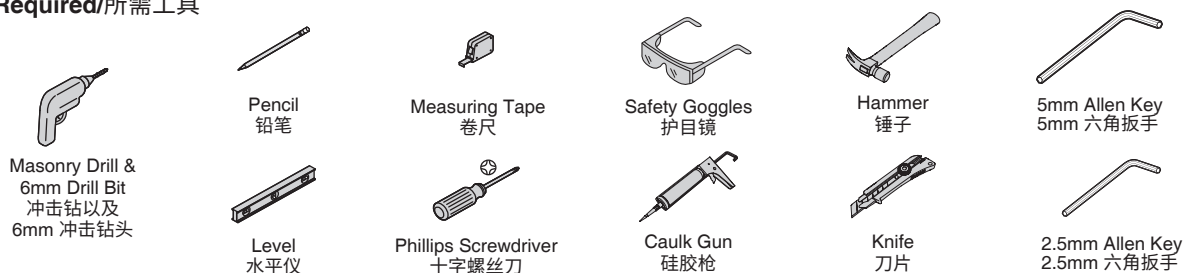

Level the ground. Place the wall materials closely against the inner edge of the drain. Draw the line and mark the position of the hole.
地面打水平。将墙材紧贴地漏内边沿划线并标上墙孔位置。

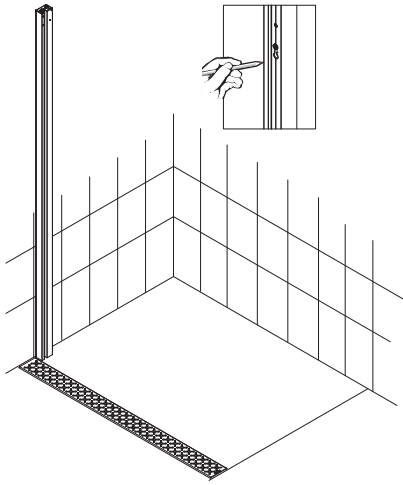

STEP 1

Assemble the door frame, note that the second rail needs to be connected by magnetic (door-closing) hinge slot.
组装门框框架，注意第二导轨需靠磁吸（关门）立柱侧锁接。

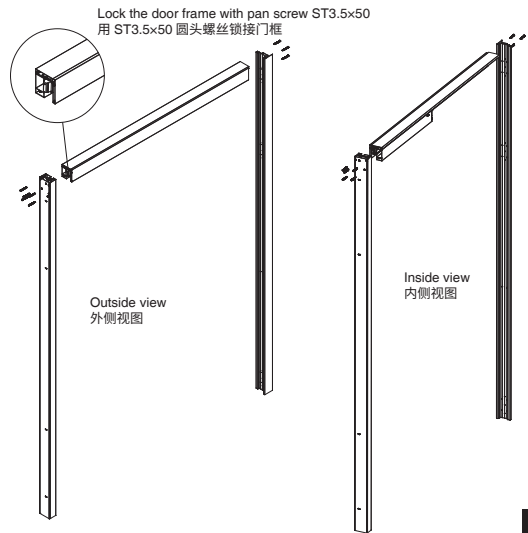

STEP 2

After locking the door frame and the side frame, install the wall materials. Fix the two wall materials to the wall with the screws.
将门框框架和侧边框架锁接后再安装墙材，用上墙螺丝分别将两支墙材固定在墙上。

Lock the wall with pan screw ST3.5x35 用 ST3.5x35 圆头螺丝锁墙
Lock the side wall with pan screw ST3.5x20 用 ST3.5x20 圆头螺丝锁侧框

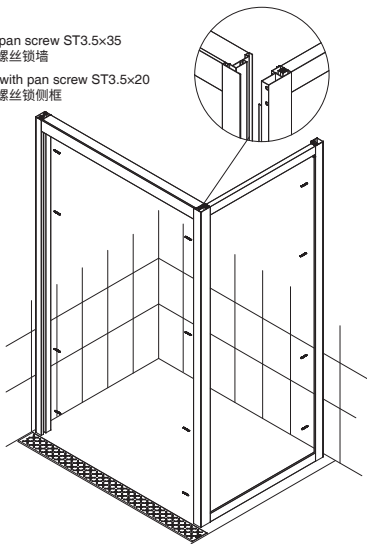

STEP 3

Install the side-hung door leaf, lock the hinge on the side-hung door leaf with screws in the hinge column slot. Install the waterproof tape (water retaining edge facing outward) and adjust the level.
安装平开门扇，将平开门扇上的铰链用螺丝锁在铰链立柱槽内，安装防水胶条（挡水边朝外）并调好水平。

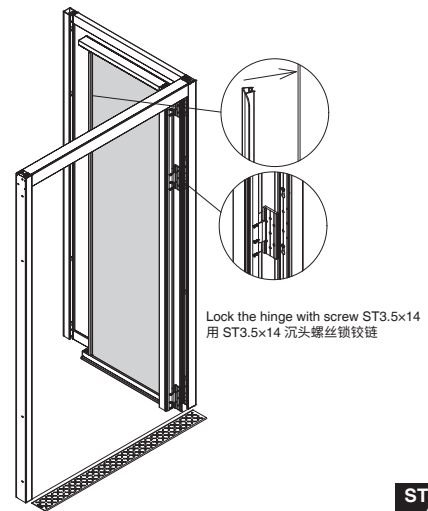

STEP 4

Install the moving door leaf, align the upper and lower grooves of the open door leaf. Then install the moving door leaf into the open door leaf.
安装推拉门扇，对准平开门扇的上导轨槽和下导轨槽，将推拉门扇装入平开门扇。

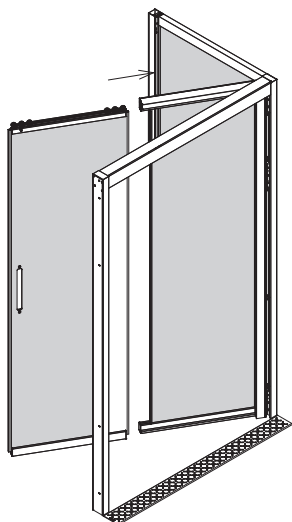

STEP 5

Adjust the adjusting screw in the wall material to make it level. Pay special attention to the level of the butt end of the upper rail. Then lock the end of the first rail.
调节墙材内的调节螺丝使之水平，特别注意上轨对接端头要水平。然后再锁好第一导轨端头。

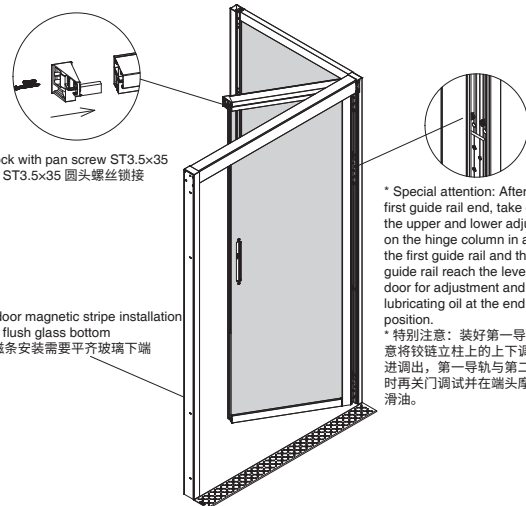

STEP 6

Sliding door magnetic stripe installation requires flush glass bottom
推拉门磁条安装需要平齐玻璃下端

* Special attention: After installing the first guide rail end, take care to adjust the upper and lower adjusting screws on the hinge column in and out. When the first guide rail and the second guide rail reach the level, close the door for adjustment and apply lubricating oil at the end friction and fit position.
* 特别注意：装好第一导轨端头后，注意将铰链立柱上的上下调节螺丝进行调进调出，第一导轨与第二导轨达到水平后再关门调试并在端头摩擦切合位抹润滑油。

Install handle. After adjusting the door bottom limit, install it at the bottom of the door.
安装拉手，调好门底限位以后安装在门底位。

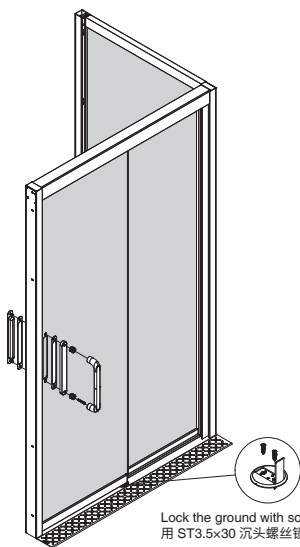

STEP
7

Fasten the magnetic strip and cover the hinged pillar decorative cover.
卡好磁条，盖好铰链立柱装饰盖。

When fastening the magnetic strip, take care to fasten the hook groove on one side of the bottom of the magnetic strip into the aluminum groove first, and then press the other side inward and downward.
卡磁条时，注意将磁条底部一侧钩槽先卡入铝材槽后，再将另一侧往里下压。

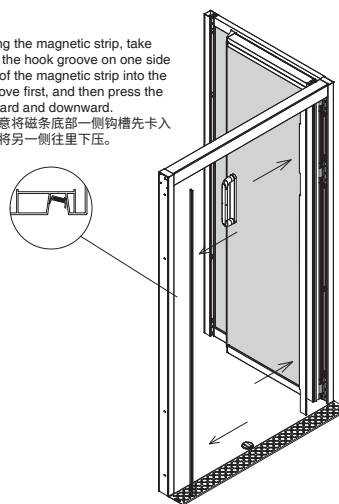

STEP
8

Apply glass glue and paste anti-collision rubber pad.
打玻璃胶，粘贴防撞胶垫。

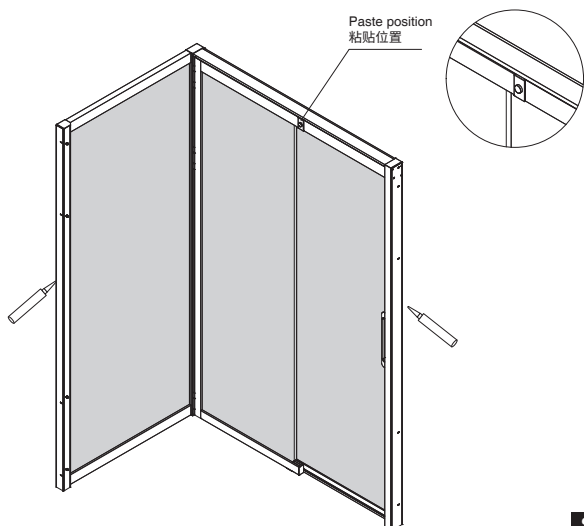

STEP
9