

Features

- Six concealed speakers send sound waves through the water to gently massage the body
- Six original instrumental compositions offer different levels of relaxation
- Syncs with devices enabled with BLUETOOTH® wireless technology including smartphones, MP3 players, tablets, and laptops located up to 33 feet (10 meters) away
- Customize your experience with the high-resolution color touch screen
- Fully-adjustable volume above and below the water
- Functions as a hydrotherapy bath when full of water and a stereo system when empty
- Slotted overflow allows for deep soaking
- Integral flange helps prevent water from seeping behind wall and simplifies alcove installation
- Includes 25' of wiring and amplifier

Material

- Acrylic

Technology

- VibrAcoustic calms and soothes with sound vibration technology

Installation

- Right drain
- Alcove
- Requires 110 V electrical service

Required Products/Accessories

- K-7271 Brass Slotted Overflow Bath Drain
- or
- K-7272 PVC Slotted Overflow Bath Drain
- or
- K-706000-D3 Frameless Sliding Bath Door
- or
- K-706000-L 62" H sliding bath door with 1/4"-thick glass
- or
- K-706004-D3 Frameless Sliding Bath Door
- or
- K-706004-L Frameless Sliding Bath Door

Recommended Products/Accessories

- 1184460 Undermount installation kit
- K-1491 Bath/Whirlpool Pillow
- K-1601 Bath/whirlpool footstop, removable
- K-23726 Drain treatment
- K-23732 Tub & shower cleaner
- K-31707 Slotted overflow bath drain kit



ADA

Codes/Standards

CSA B45.5/IAPMO Z124
ASTM E162
ASTM E662
UL 1795
CSA C22.2 No. 218.2
ADA
ICC/ANSI A117.1
IAPMO Certification
cUL Listed
UL Listed

KOHLER® Plastic Baths and Shower Bases Lifetime Limited Warranty KOHLER® Hydrotherapy Components Five-Year Limited Warranty

See website for detailed warranty information.

The BLUETOOTH® word mark and logos are registered trademarks owned by Bluetooth SIG, Inc. and any use of such marks by Kohler Co. is under license. Other trademarks and trade names are those of their respective owners.

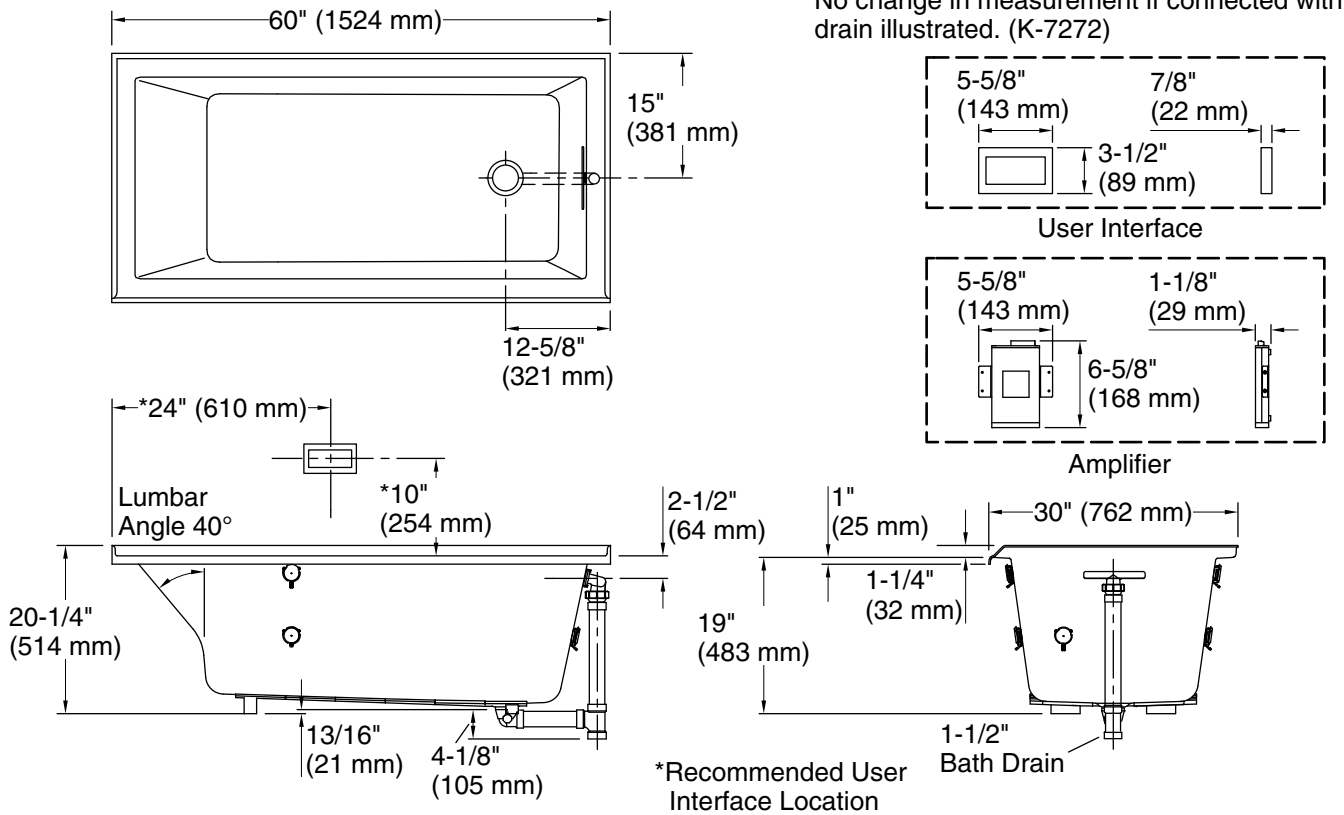

Required Electrical Service

One circuit required, protected with Class A Ground-Fault Circuit-Interrupter (GFCI). Outside North America, this device may be known as a Residual Current Device (RCD).

Amplifier: 120 V, 15 A, 50/60 Hz

Technical Information

All product dimensions are nominal.

Drain location:	Right
Basin area, bottom:	42-3/8" x 20" (1076 mm x 508 mm)
Basin area, top:	54-3/8" x 24-5/16" (1381 mm x 618 mm)
Weight:	80 lbs (36.3 kg)
Minimum floor load:	50 lbs/ft ² (244.1 kg/m ²)
Water depth:	15-1/16" (383 mm)
Water capacity:	59.8 gal (226.4 L)
Electrical component rating:	Amplifier: 120 V, 1.1 A, 50/60 Hz
Amplifier channels:	2 at 15 W per channel 2 at 30 W per channel
Minimum flat for door:	1-15/16" (49 mm)

Notes

Measure your actual product for rough-in details.

Install this product according to the installation instructions.

The hot water supply should be 70% of the capacity of the bath or greater. Installations will vary.

Control amplifier fits 16" (406 mm) center studs. 25' (7.6 m) cables are included.

IMPORTANT! Due to BLUETOOTH signal overlap, installations of multiple baths within 50 ft (15.2 m) of each other will require special order product. Please contact your dealer, showroom, or sales representative for ordering assistance.

ADA compliant when installed to the specific requirements of these regulations.