

## Features

- Asymmetrical oval basin
- No faucet holes; requires wall- or counter-mount faucet
- Overflow drain
- Includes color-matched overflow cap and color-matched brass drain cover
- Coordinates with other products in the Veil collection

## Material

- Fireclay

## Installation

- Vessel

## Required Products/Accessories

K-7114-A Pop-Up Drain

or

K-7126 Standard pop-up drain, non-exposed, with lift rod

## Recommended Products/Accessories

K-23726 Drain treatment

K-23725 Cast iron cleaner

## Included Components

1311408 Faucet Cap Assembly

1331521 Drain Cover Kit



ADA

CSA B651

## Codes/Standards

ASME A112.19.2/CSA B45.1

ADA

ICC/ANSI A117.1



CSA B651

IAPMO Certification

See website for detailed warranty information.

## Available Colors/Finishes

*Color tiles intended for reference only.*

Color	Code	Description
	0	White
	96	Biscuit
	7	Black Black™

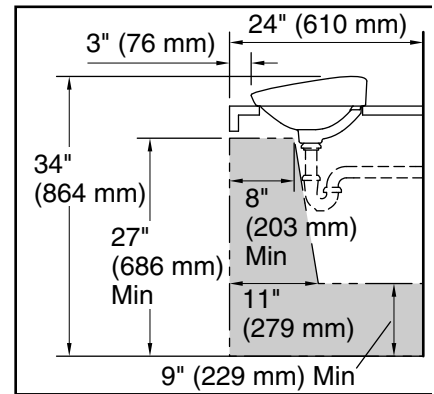
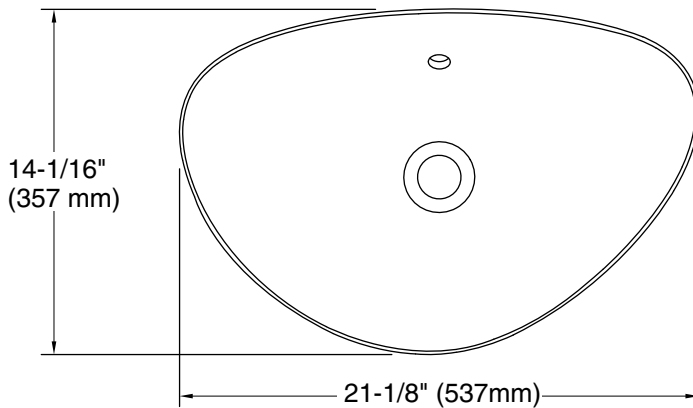

Recommended ADA Installation

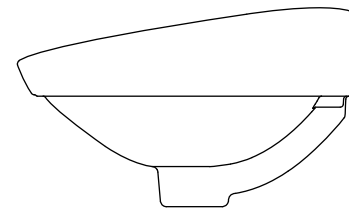
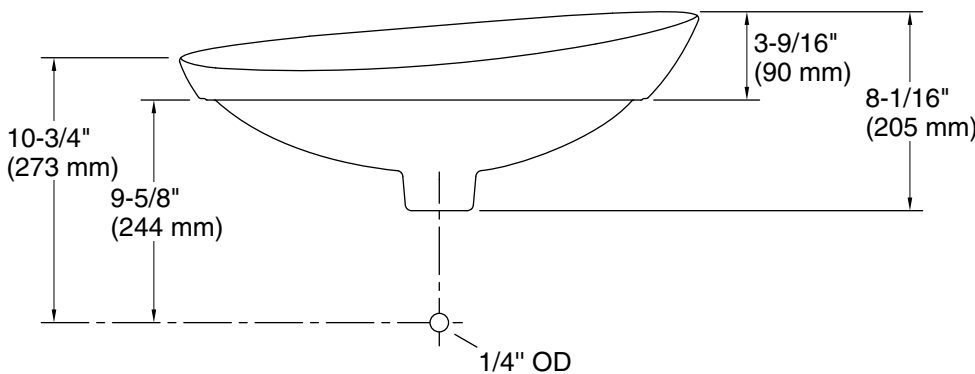

## Technical Information

All product dimensions are nominal.

Bowl area (Only):	Length: 20-9/16" (522 mm)
	Width: 13-9/16" (344 mm)
	Bowl depth: 3-5/8" (91 mm)
Drain hole:	1-3/4" (44 mm)
Template:	1317551-7, not required, included

## Notes

Install this product according to the installation instructions.

**NOTICE:** Countertop manufacturer or cutter must use the cut-out template provided with the product, or a current one provided by Kohler Co. (call 1-800-4-KOHLER). Kohler Co. is not responsible for cutout errors when the incorrect cut-out template is used.

ADA, CSA B651 compliant when installed to the specific requirements of these regulations.