



Branham™

Full stall washout urinal with top spud
K-25039-T

Features

- Full stall washdown urinal
- 0.5 or 1.0 gpf (1.9 or 3.8 lpf)
- Lip of urinal installs below floor level for easier cleaning around fixture
- Full length sidewalls provide added privacy
- External trapway
- 3/4" (19 mm) top spud
- Drain sold separately

Material

- Vitreous china

Installation

- Replaces K-4920-T

Recommended Products/Accessories

- K-23726 Drain treatment
- K-23725 Cast iron cleaner

Included Components

- 18376 Urinal Spud Accessory 3/4"



ADA **CSA B651** **OBC**

Codes/Standards



ASME A112.19.2/CSA B45.1
DOE - Energy Policy Act 1992
EPA WaterSense®
California Energy Commission (CEC)
ADA
ICC/ANSI A117.1
CSA B651
OBC
IAPMO Certification

KOHLER® One-Year Limited Warranty

See website for detailed warranty information.

Available Colors/Finishes

Color tiles intended for reference only.

Color	Code	Description
	0	White
	96	Biscuit
	7	Black Black™

1-800-4KOHLER (1-800-456-4537)

Kohler Co. reserves the right to make revisions without notice to product specifications.

For the most current Specification Sheet, go to www.kohler.com USA or www.kohler.ca Canada

9-26-2024 08:30 - US/CA

THE BOLD LOOK
OF **KOHLER**®

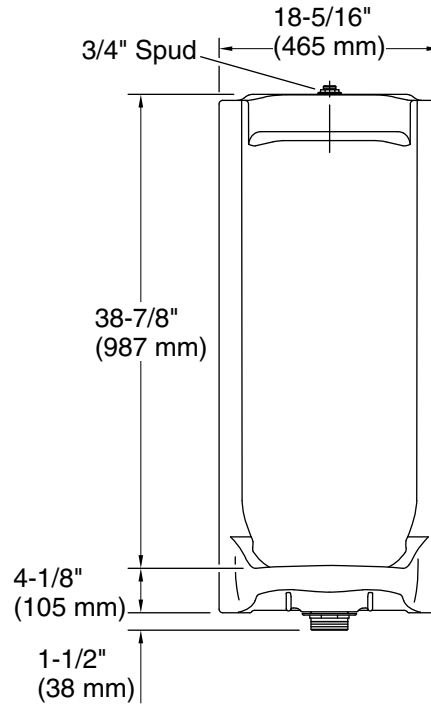
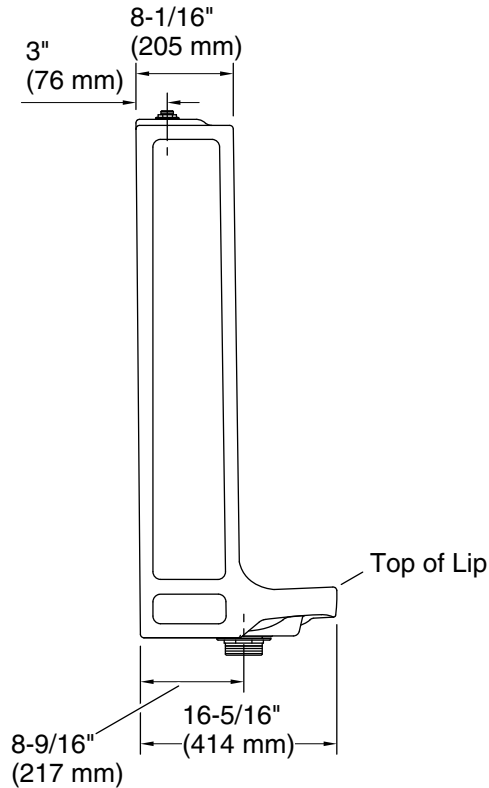

Technical Information

All product dimensions are nominal.

Spud size: 3/4, Inlet, Top

Min. Water per Flush: 0.5 gpf (1 lpf)

Max. Water per Flush: 1 gpf (3.8 lpf)

Designed for the above water use when installed with a water-saving flushometer.

Pressure and Supply Requirements

Fixture pressure min (static): 20 psi (137.9 kPa)

Fixture pressure max (static): 80 psi (551.6 kPa)

Notes

Install this product according to the installation instructions.

Refer to manufacturer's instructions and local codes for flushometer requirements.

ADA, OBC, CSA B651 compliant when installed to the specific requirements of these regulations.