

Features

- For use with KOHLER® in-wall tank and carrier system (sold separately)
- Water-saving dual-flush faceplate offers two flushing options
- Pneumatic manual flush buttons feel soft and smooth to the touch
- Faceplate is easily removed, allowing access to inner tank and flush valve for service
- Fingerprint-resistant finish stays clean longer
- Available in a range of colors and finishes

Material

- Durable metal construction

Installation

- Wall-mount
- Choice of installation position to suit user habits

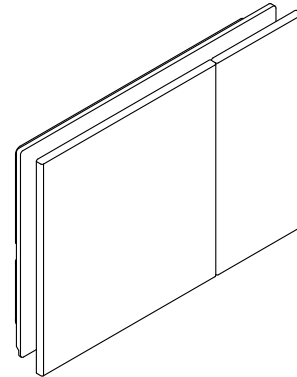

Codes/Standards

None Applicable

See website for detailed warranty information.

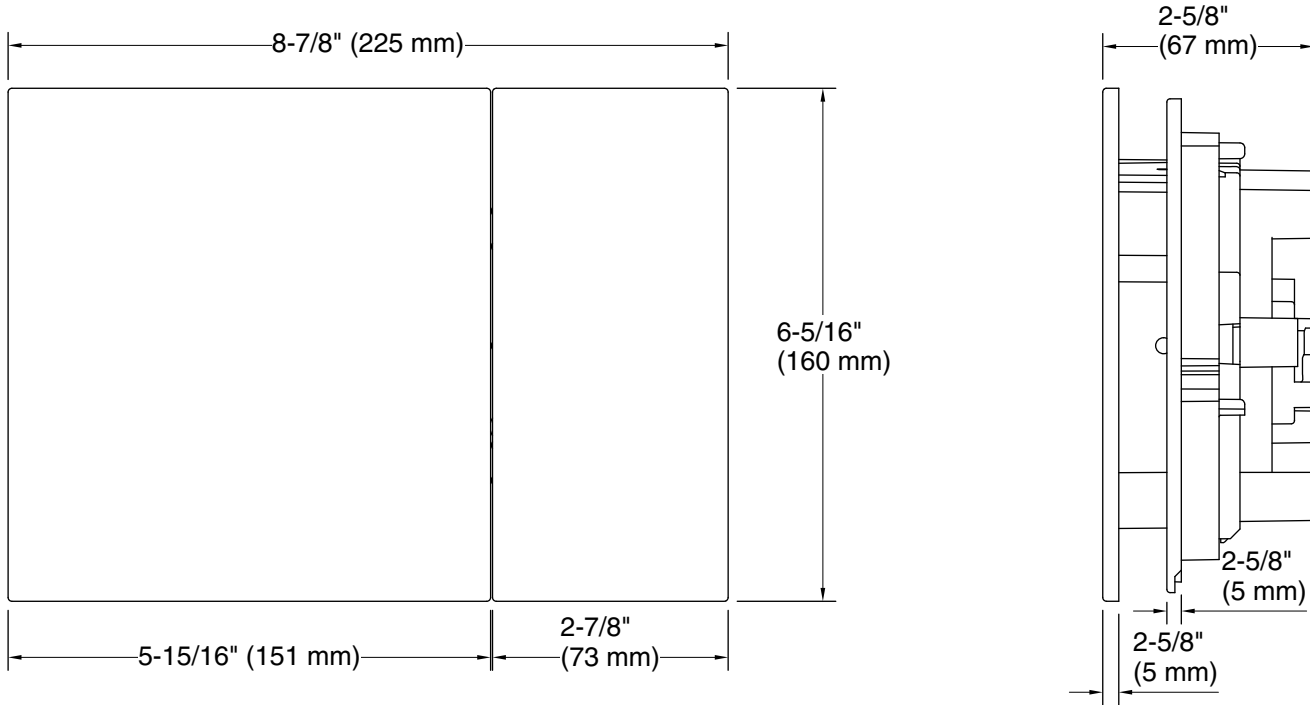

Technical Information

All product dimensions are nominal.

Material: Brass/Plastic

Notes

Install this product according to the installation instructions.