



Mach Flex™ | K-36226

DC long-life battery pack for concealed touchless flushometers

Features

- Long-life D-cell lithium battery
- Provides over 10 years of continuous performance (based on 80 activations per day)
- Includes battery, mounting bracket, and screws



Available Colors/Finishes

Color tiles intended for reference only.

^{NA} NA Not Applicable



1-800-4KOHLER (1-800-456-4537)
Kohler Co. reserves the right to make revisions without notice to product specifications.
For the most current specification sheet, go to www.kohler.com USA or www.kohler.ca Canada.
5-30-2026 21:18 - US-CA

THE BOLD LOOK
OF **KOHLER**

Codes/Standards

None Applicable

Material

- Fully potted with durable plastic housing
-

Warranty

See website for detailed warranty information.

KOHLER® One-Year Limited Warranty



1-800-4KOHLER (1-800-456-4537)

Kohler Co. reserves the right to make revisions without notice to product specifications.
For the most current specification sheet, go to www.kohler.com USA or www.kohler.ca Canada.
5-30-2026 21:18 - US-CA

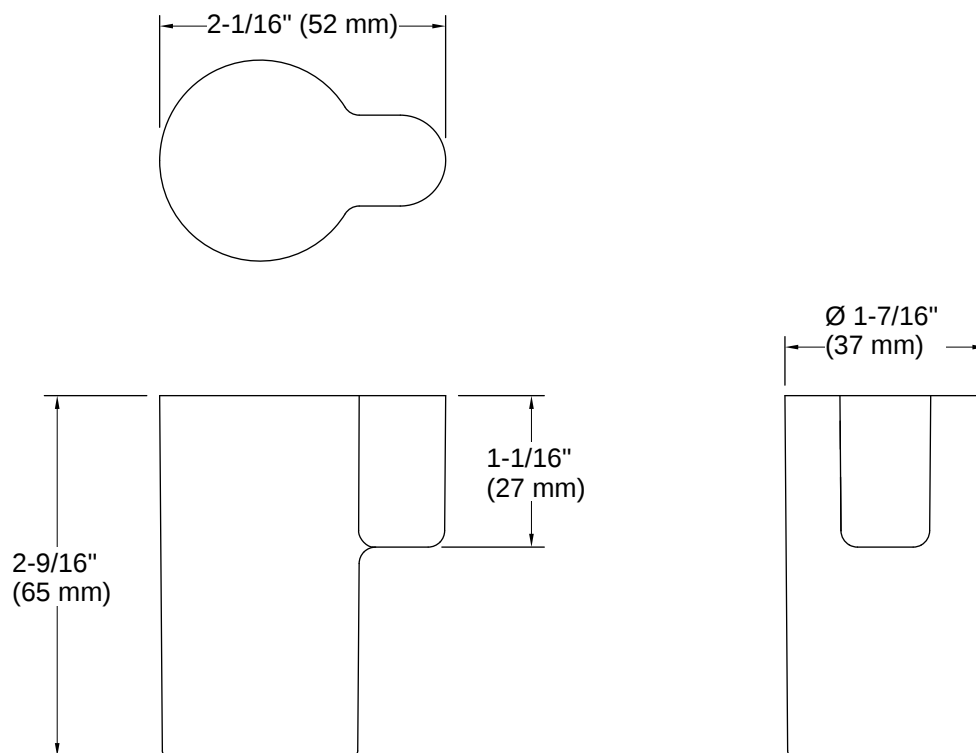

Installation Notes

Install this product according to the installation instructions.

