

Features

- Easy-to-read LCD display and raised one-touch buttons
- Integrated diverter lets you toggle between three water outlets
- Digital thermostatic valve ensures safe and accurate temperature control
- Warm-up mode reaches set temperature and then pauses until you're ready
- Additional pause function stops water flow for up to two minutes
- Countdown mode allows you to set shower duration to save and manage time and water use
- Ideal for new installation or retrofit to existing shower

Installation

- Includes prewired plug-and-play electrical connections
- Install valve up to 20' (6.1 meters) away from the digital interface (cable supplied with interface)
- Distance can be extended with a standard RJ-11 phone extension cord



ADA

Codes/Standards

UL 1951
ADA
ICC/ANSI A117.1
UL Listed

KOHLER® Electronic Faucets, Valves, and Controls Five-Year Limited Warranty

See website for detailed warranty information.

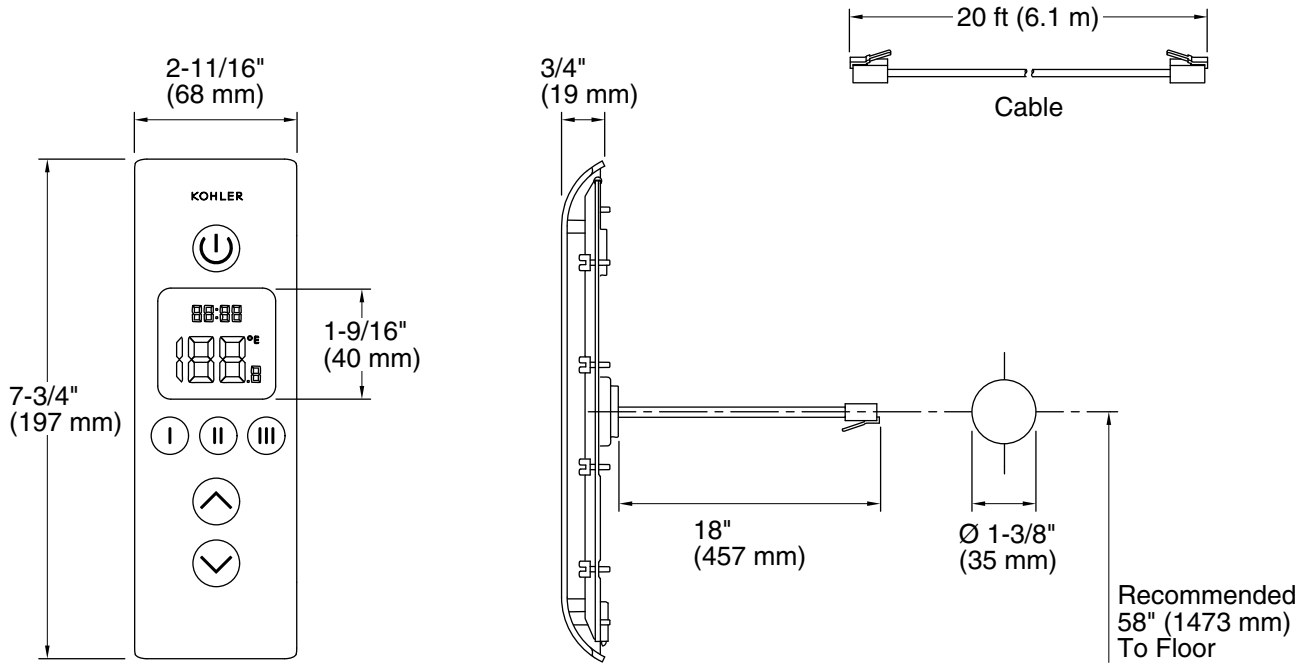

Technical Information

All product dimensions are nominal.
 Max. Ambient temp: 125°F (51.7°C)
 Max. Relative humidity non-condensing: 100%

Notes

Install this product according to the installation instructions.
 ADA compliant when installed to the specific requirements of these regulations.