

Features

- Six concealed speakers send sound waves through the water to gently massage the body
- Six original instrumental compositions offer different levels of relaxation
- Syncs with devices enabled with BLUETOOTH® wireless technology including smartphones, MP3 players, tablets, and laptops located up to 33 feet (10 meters) away
- Customize your experience with the high-resolution color touch screen
- Fully-adjustable volume above and below the water
- Functions as a hydrotherapy bath when full of water and a stereo system when empty
- Integral lumbar support
- Oval basin creates a spacious bathing experience
- Slotted overflow allows for deep soaking
- Includes 25' of wiring and amplifier

Material

- Acrylic

Technology

- VibrAcoustic calms and soothes with sound vibration technology

Installation

- Requires K-7271 or K-7272 Clearflo slotted overflow bath drain (sold separately)
- Center drain
- Drop-in or undermount
- Requires 110 V electrical service

Required Products/Accessories

K-7271 Brass Slotted Overflow Bath Drain

or

K-7272 PVC Slotted Overflow Bath Drain

Recommended Products/Accessories

K-883 Under-Mount Installation Kit

K-23726 Drain treatment

K-23732 Tub & shower cleaner

K-31797 Slotted overflow bath drain kit

K-31795 Slotted overflow above-the-floor bath drain kit



Codes/Standards

CSA B45.5/IAPMO Z124

ASTM E162

ASTM E662

UL 1795

CSA C22.2 No. 218.2

IAPMO Certification

cUL Listed

UL Listed

KOHLER® Plastic Baths and Shower Bases Lifetime Limited Warranty KOHLER® Hydrotherapy Components Five-Year Limited Warranty

See website for detailed warranty information.

The BLUETOOTH® word mark and logos are registered trademarks owned by Bluetooth SIG, Inc. and any use of such marks by Kohler Co. is under license. Other trademarks and trade names are those of their respective owners.

No change in measurements if connected with drain illustrated. (K-7272)

□ Recommended Faucet Location

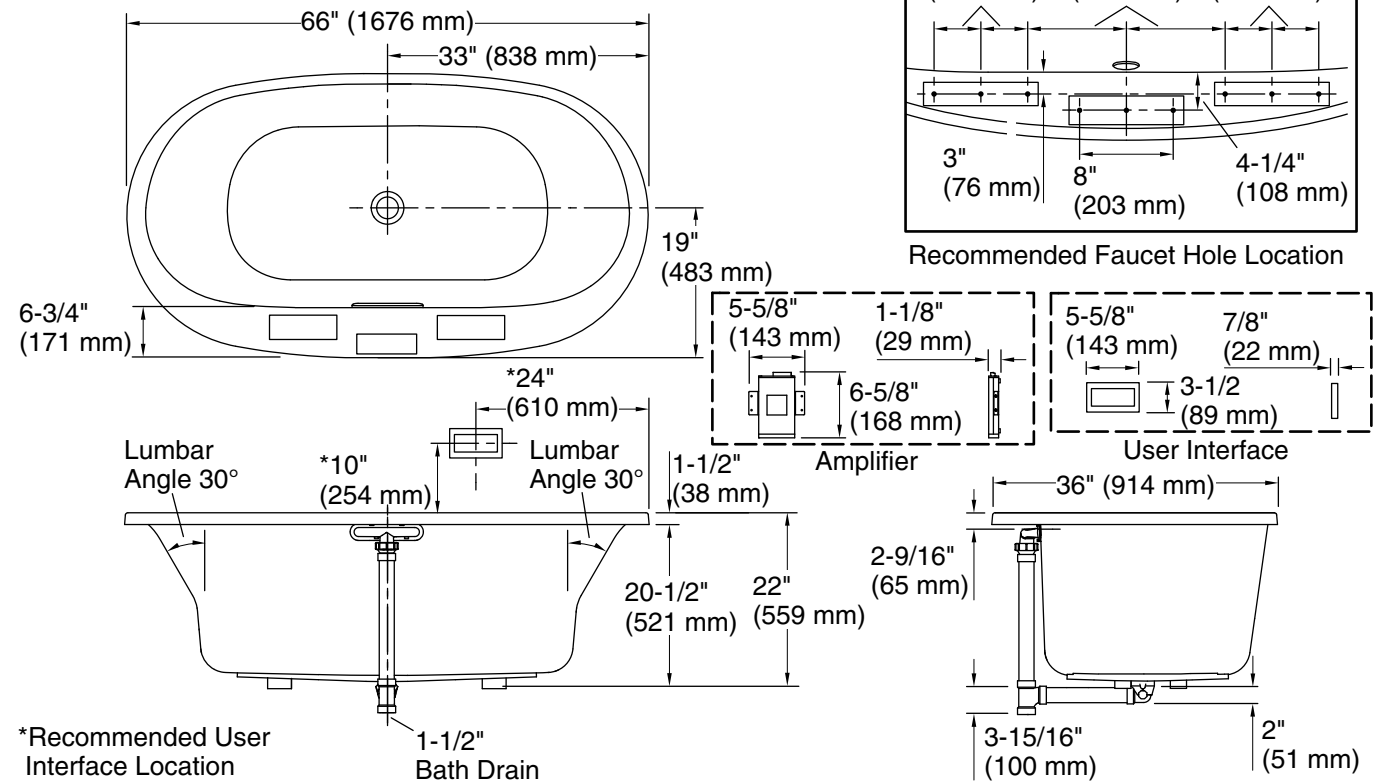

Required Electrical Service

One circuit required, protected with Class A Ground-Fault Circuit-Interrupter (GFCI). Outside North America, this device may be known as a Residual Current Device (RCD).

Amplifier: 120 V, 15 A, 50/60 Hz

Technical Information

All product dimensions are nominal.

Drain location: Center
 Basin area, bottom: 47" x 26-1/4" (1193 mm x 666 mm)
 Basin area, top: 61-3/16" x 28-3/8" (1554 mm x 721 mm)
 Weight: 95 lbs (43.1 kg)
 Minimum floor load: 52 lbs/ft² (253.9 kg/m²)
 Water depth: 17-9/16" (446 mm)
 Water capacity: 85.5 gal (323.7 L)
 Template: Drop-in, 1268439-7, required, included
 Electrical component rating: Amplifier: 120 V, 1.1 A, 50/60 Hz

Amplifier channels: 2 at 15 W per channel
 2 at 30 W per channel

Bluetooth® range: 33 ft (10.1 m)

1-800-4KOHLER (1-800-456-4537)

Kohler Co. reserves the right to make revisions without notice to product specifications.

For the most current Specification Sheet, go to www.kohler.com USA or www.kohler.ca Canada

8-12-2024 22:20 - US/CA

Notes

Measure your actual product for rough-in details.

Install this product according to the installation instructions.

The hot water supply should be 70% of the capacity of the bath or greater. Installations will vary.

If installing a rim-mount faucet, make sure there is no interference above or below the deck before drilling any holes.

IMPORTANT! Due to BLUETOOTH signal overlap, installations of multiple baths within 50 ft (15.2 m) of each other will require special order product. Please contact your dealer, showroom, or sales representative for ordering assistance.