

Features

- Brass construction and valve bodies
- Three-hole installation for 8" to 16" centers
- Quarter-turn washerless ceramic disc valves
- Less drain and lift rod
- Vandal-resistant laminar outlet
- Lever handles
- 5-1/2" (140 mm) spout reach
- 0.5 gpm (1.9 lpm) maximum flow rate at 60 psi (4.14 bar)

Recommended Products/Accessories

K-23723 Faucet cleaner



ADA

CSA B651

OBC

Codes/Standards

ASME A112.18.1/CSA B125.1

NSF/ANSI/CAN 61

NSF/ANSI/CAN 372

All applicable US Federal and State material regulations

DOE - Energy Policy Act 1992

California Energy Commission (CEC)

ADA

ICC/ANSI A117.1

CSA B651

OBC

IAPMO Certification

KOHLER® One-Year Limited Warranty

See website for detailed warranty information.

Available Colors/Finishes

Color tiles intended for reference only.

Color	Code	Description
-------	------	-------------

	CP	Polished Chrome
---	----	-----------------

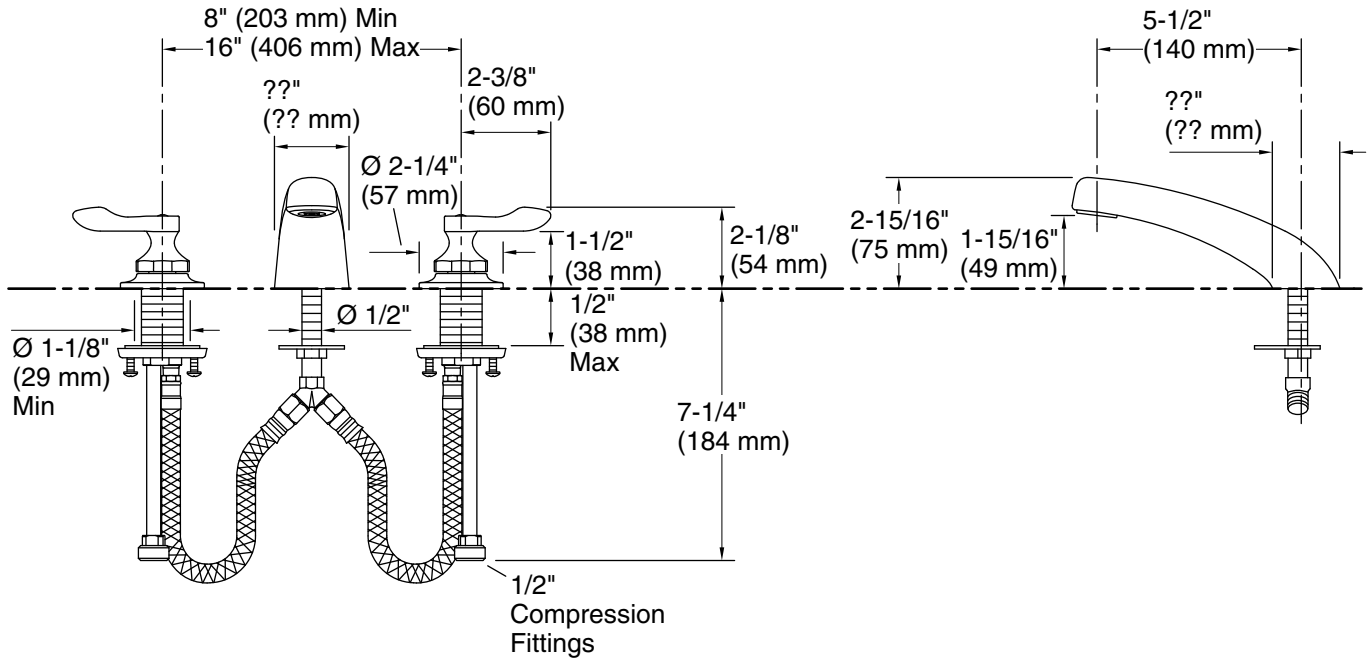

Technical Information

All product dimensions are nominal.

Faucet:

Flow rate: 0.5 gal/min (1.9 l/min)

Drain included: No

Spout:

Spout reach: 5-1/2" (140 mm)

Handshower:

Rated maximum flow: 0 gal/min (0 l/min)

Notes

Install this product according to the installation guide.

ADA compliant for handles only.

ADA, OBC, CSA B651 compliant when installed to the specific requirements of these regulations.