

RSA III

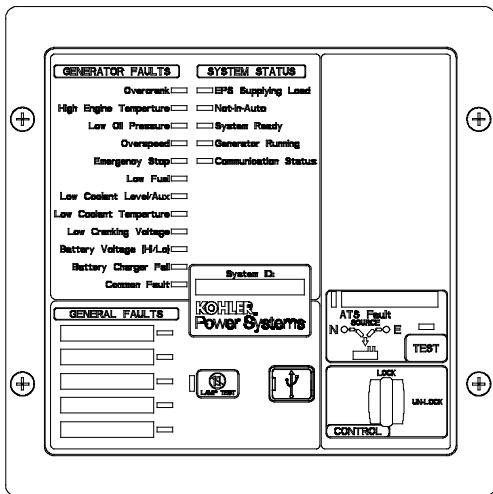

RSA III with a Single ATS Control

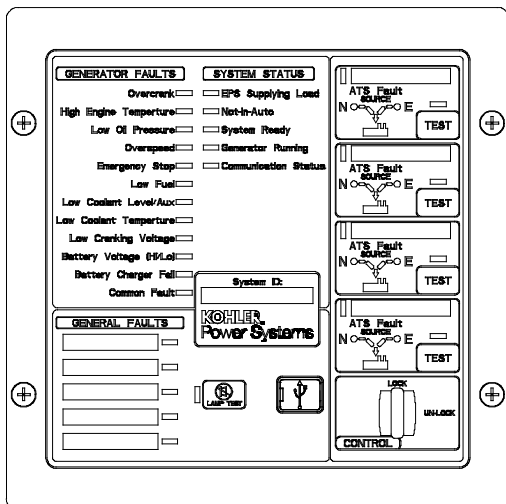

RSA III with Four ATS Controls

### Remote Serial Annunciator III (RSA III) for Kohler® Controllers

- Monitors the generator set equipped with one of the following controllers:
 

APM402	Decision-Maker® 3000
APM603	Decision-Maker® 3500
APM802	Decision-Maker® 6000
Decision-Maker® 3+	Decision-Maker® 8000
Decision-Maker® 550	KPC 1000
- Allows monitoring of the common alarm, remote testing of the automatic transfer switch, and monitoring of the normal/emergency source for up to four ATS with any of the following controllers:
 

Decision-Maker® MPAC® 750, 1200, and 1500
MPAC® 1000 and 1500
- Configuration via a personal computer (PC) software.
- Writable surfaces (white boxes in illustrations) for user-defined selections.
- Uses Modbus® RTU protocol.
- Controller connections:
  - RS-485 for serial bus network
  - USB port. Connect a personal computer and use Kohler® SiteTech™ software to view events and adjust settings. \*
  - 12-/24-volt DC power supply
  - 120/208 VAC power supply (available accessory)
- Meets the National Fire Protection Association Standard NFPA 110, Level 1.

### Dimensions

- Dimensions—W x H x D, mm (in.).
- Surface Mounted:**  
203 x 203 x 83 (8.0 x 8.0 x 3.3)
- Flush Mounted (Inside Wall):**  
203 x 203 x 76 (8.0 x 8.0 x 3.0)
- Flush mounting plate W1: 254 (10.0)

\* SiteTech™ software is available to Kohler authorized distributors and dealers.

Modbus® is a registered trademark of Schneider Electric.

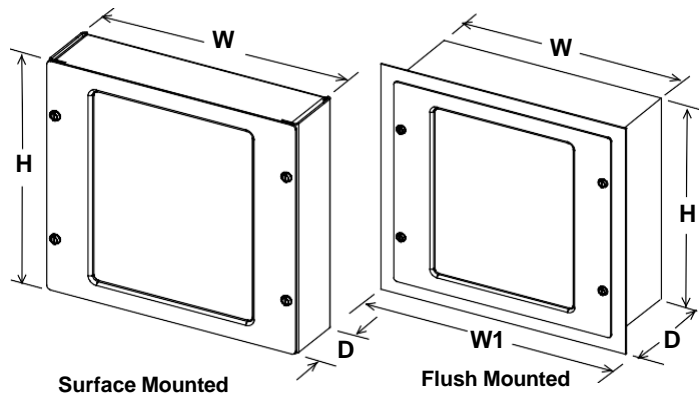

Fault and Status Conditions	Fault LEDs	Fault Horn	System Ready LED	Generator Running LED	Communication Status LED
Overcrank Shutdown	Red	On	Red	Off	Green
High Engine Temperature Warning *	Yellow	On	Red	Green	Green
High Engine Temperature Shutdown	Red	On	Red	Off	Green
Low Oil Pressure Warning *	Yellow	On	Red	Green	Green
Low Oil Pressure Shutdown	Red	On	Red	Off	Green
Overspeed Shutdown	Red	On	Red	Off	Green
Emergency Stop *	Red	On	Red	Off	Green
Low Coolant Level/Aux. Shutdown	Red	On	Red	Off	Green
Low Coolant Temperature *	Yellow	On	Red	Off	Green
Low Cranking Voltage	Yellow	On	Red	Off	Green
Low Fuel—Level or Pressure *	Yellow	On	Red	Green or Off	Green
Not-In-Auto	Red	On	Red	Green or Off	Green
Common Fault	Red/Yellow	On	Green	Green or Off	Green
Battery Charger Fault (1) *	Yellow	On	Red	Green or Off	Green
Battery Charger Fault (2) *	Yellow	On	Green	Green or Off	Green
High Battery Voltage *	Yellow	Off	Green	Green or Off	Green
Low Battery Voltage *	Yellow	Off	Green	Green or Off	Green
User Input #1 (Warning)	Yellow	Off	Green	Green or Off	Green
User Input #1 (Shutdown)	Red	On	Green	Off	Green
User Input #2 (Warning)	Yellow	Off	Green	Green or Off	Green
User Input #2 (Shutdown)	Red	On	Green	Off	Green
User Input #3 (Warning) (1) †	Yellow	Off	Green	Green or Off	Green
User Input #3 (Shutdown) (1) †	Red	On	Green	Off	Green
User Input #4 (Warning) (1)	Yellow	Off	Green	Green or Off	Green
User Input #4 (Shutdown) (1)	Red	On	Green	Off	Green
User Input #5 (Warning) (1)	Yellow	Off	Green	Green or Off	Green
User Input #5 (Shutdown) (1)	Red	On	Green	Off	Green
EPS Supplying Load	Yellow	Off	Green	Green	Green
Communications Status (Fault mode)	—	Off	Green or Red	Green or Off	Red
ATS Fault (RSA III with ATS Controls only)	Red	On	Red or Yellow	Green or Off	Green

Green LEDs appear as steady on when activated.  
Yellow (common warning) LEDs slow flash when activated except steady on with EPS supplying load and high battery voltage.  
Red (common fault) LEDs slow flash when activated except fast flash with loss of communication and not-in-auto.

## Specifications

- LED indicating lights for status, warning, and/or shutdown.
- Power source with circuit protection: 12- or 24-volt DC
- Power source with 120/208 VAC, 50/60 Hz adapter (option)
- Power draw: 200 mA
- Humidity range: 0% to 95% noncondensing
- Operating temperature range: -20°C to +70°C (-4°F to +158°F)
- Storage temperature range: -40°C to +85°C (-40°F to +185°F)
- Standards:
  - NFPA 110, level 1
  - UL 508 recognized
  - CE directive
  - NFPA 99
  - ENS 61000-4-4
  - EN611-4-4 fast transient immunity
- RS-485 Modbus® isolated port @ 9.6/19.2/38.4/57.6 kbps (default is 19.2 kbps)
- USB device port
- NEMA 1 enclosure
- (1) All generator set controllers except Decision-Maker® 3+ controller.
- (2) Decision-Maker® 3+ controller only.
- \* May require optional kit or user-provided device to enable function and LED indication.
- † Digital input #3 is factory-set for high battery voltage on the Decision-Maker® 3+ controller.

Modbus® is a registered trademark of Schneider Electric.

## ATS Controls (RSA III with ATS controls only)

- ATS position LED (normal or emergency)
- Power source indicator LED (normal or emergency)
- ATS fault LED
- Key-operated lock/unlock switch for Test feature
- Test pushbutton

## NFPA Requirements

- NFPA 110 compliant
- Engine functions:
  - High battery voltage warning \*
  - High engine temperature shutdown
  - High engine temperature warning \*
  - Low battery voltage warning \*
  - Low coolant level/aux. shutdown
  - Low coolant temperature warning \*
  - Low cranking voltage
  - Low fuel warning (level or pressure) \*
  - Low oil pressure shutdown
  - Low oil pressure warning \*
  - Overcrank shutdown
  - Overspeed shutdown
- General functions:
  - Audible alarm silence
  - Battery charger fault \*
  - Lamp test
  - Master switch not-in-auto

---

## Fault and Status LEDs and Lamp Test Switch

**Alarm Horn.** Horn sounds giving a minimum 90 dB at 0.1 m (0.3 ft.) audible alarm when a warning or shutdown fault condition exists except on high/low battery voltage or EPS supplying load.

**Alarm Silenced.** Red LED on lamp test switch lights when alarm horn is deactivated by alarm silence switch.

**Alarm Silence Switch.** Lamp test switch quiets the alarm during servicing. The horn will reactivate upon additional faults.

**ATS Fault.** Red LED lights when ATS fails to transfer.

**Battery Charger Fail.** LED lights if battery charger malfunctions. Requires battery charger with alarm contact.

**Battery Voltage Hi/Lo.** LED flashes if battery or charging voltage drops below preset level. LED lights steady if battery voltage exceeds preset level.

**Common Fault.** LED lights when a single or multiple common faults occur.

**Communication Status.** Green LED lights indicating annunciator communications functional. Red LED indicates communication fault.

**EPS Supplying Load.** LED lights when the Emergency Power System (EPS) generator set is supplying the load (APM402, APM603, APM802, and Decision-Maker® 550, 3000, 3500, 6000, and 8000 controllers) or when transfer switch is in the emergency position (Decision-Maker® 3+ controller).

**Emergency Stop.** LED lights and engine stops when emergency stop is made. May require a local emergency stop switch on some Decision-Maker® 3+ controllers.

**Generator Running.** LED lights when generator set is in operation.

**High Engine Temperature.** Red LED lights if engine has shut down because of high engine coolant temperature. Yellow LED lights if engine coolant temperature approaches shutdown range. Requires warning sender on some models.

**Lamp Test (Switch).** Switch tests all the annunciator indicator LEDs and horn.

**Low Coolant Level/Aux.** LED lights when engine coolant level is below acceptable range on radiator-mounted generator sets only. When used with a Decision-Maker® 3+ controller, the LED indicates low coolant level or an auxiliary fault shutdown. Requires user-supplied low coolant level switch on remote radiator models.

**Low Coolant Temperature.** LED lights if optional engine block heater malfunctions and/or engine coolant temperature is too low. Requires prealarm sender on some models.

**Low Cranking Voltage.** LED lights if battery voltage drops below preset level during engine cranking.

**Low Fuel (Level or Pressure).** LED lights if fuel level in tank approaches empty with diesel models or fuel pressure is low on gas models. Requires customer-supplied switch.

**Low Oil Pressure.** Red LED lights if generator set shuts down because of insufficient oil pressure. Yellow LED lights if engine oil pressure approaches shutdown range. Requires warning sender on some models.

**Not In Auto.** LED lights when the generator set controller is not set to automatic mode.

**Overcrank.** LED lights and cranking stops if engine does not start in either continuous cranking or cyclic cranking modes.

**Overspeed.** LED lights if generator set shuts down because of overspeed condition.

**System Ready.** Green LED lights when generator set master switch is in AUTO position and the system senses no faults. Red LED indicates system fault.

**User-Defined Digital Inputs #1- #5.** Monitors five digital auxiliary inputs (can be configured as warnings or shutdowns). User-defined digital inputs are selected via the RSA III master for local or remote (generator set or ATS). The user-defined digital input can be assigned via PC using SiteTech™ setup software.

## Accessories

- Power source adapter kit 120/208 VAC, 50/60 Hz.
- Modbus®/Ethernet converter GM41143-KP2 for serial to Ethernet communication.
- Communication module GM32644-KA1 or GM32644-KP1 is required with Decision-Maker® 3+ controllers.

Modbus® is a registered trademark of Schneider Electric.

**DISTRIBUTED BY:**

Availability is subject to change without notice. Kohler Co. reserves the right to change the design or specifications without notice and without any obligation or liability whatsoever. Contact your local Kohler® generator set distributor for availability.

© 2014 by Kohler Co. All rights reserved.